

20/  
18

CATALOGO GENERALE  
GENERAL CATALOGUE

**LEA**  
CERAMICHE



# INDEX / ABC

**A/** ABSOLUTE  
SLIMTECH  
62

**B/** BASALTINA STONE PROJECT  
272

BASALTINA STONE PROJECT  
SLIMTECH  
96

BIO LUMBER  
310

BIO PLANK  
326

BIO RECOVER  
302

BIO TIMBER  
318

**C/** CITY  
330

CLIFFSTONE  
260

**D/** DISTRICT  
196

DREAMING  
288

**G/** GOCCIA  
334

GOUACHE.10 AND LIBECCIO  
SLIMTECH  
76

**L/** LINES AND WAVES  
SLIMTECH  
154

LINK  
342

**M/** MAKÒ  
220

MAUK  
SLIMTECH  
170

METROPOLIS  
210

**N/** NAIVE  
SLIMTECH  
146

NEST  
SLIMTECH  
166

NEXTONE  
232

**R/** RE-EVOLUTION  
SLIMTECH  
68

**S/** SHADE AND STREETS  
SLIMTECH  
82

STONECLAY  
226

SYSTEM L2  
346

**T/** TAKE CARE AND PAD  
SLIMTECH  
46

TECNOQUARTZ  
280

TIMELESS MARBLE AND FILIGRANE  
SLIMTECH  
106

TRAME  
184

TYPE 32  
SLIMTECH  
134

**W/** WATERFALL  
248

WATERFALL  
SLIMTECH  
88

WOOD-STOCK  
SLIMTECH  
124

## INDICE

index / index / Inhalt

AZIENDA  
4

PROTECT  
40

SLIMTECH  
42

GRES AND MORE  
180

TECHNICAL INFO  
352

LEGENDA CODICI  
PRODOTTO / IMBALLI  
381

# indice analitico /

	COLLEZIONE PRODUCT	PAGINA PAGE	PROTECT	DESIGN BY
SLIMTECH	ABSOLUTE	62	( P )	
	BASALTINA STONE PROJECT	96		
	GOUACHE.10 AND LIBECCIO	76		LIBECCIO Diego Grandi
	LINES AND WAVES	154		Patrick Norguet
	MAUK	170		Diego Grandi
	NAIVE	146		Patrick Norguet
	NEST	166		HOK Product Design
	RE-EVOLUTION	68		
	SHADE AND STREETS	82		STREETS Diego Grandi
	TAKE CARE AND PAD	46	( P )	PAD Patrick Norguet
	TIMELESS MARBLE AND FILIGRANE	106	( P )	FILIGRANE Philippe Nigro
	TYPE 32	134		Diego Grandi
	WATERFALL	88	( P )	
	WOOD-STOCK	124	( P )	
GRES AND MORE	BASALTINA STONE PROJECT	272		
	BIO LUMBER	310	( P )	
	BIO PLANK	326	( P )	
	BIO RECOVER	302	( P )	
	BIO TIMBER	318	( P )	
	CITY	330		Diego Grandi
	CLIFFSTONE	260	( P )	
	DISTRICT	196	( P )	
	DREAMING	288		
	GOCCIA / MONOPOROSA	334		Kravitz Design Inc.
	MAKÒ	220		
	METROPOLIS	210	( P )	
	NEXTONE	232	( P )	
	STONECLAY / HOME	226		
	TECNOQUARTZ	280		
	TRAME	184	( P )	
	WATERFALL	248	( P )	
	LINK / PERCORSI TATTILI	342		
	SYSTEM L2 / 20 MM	346		





# When Creativity meets Performance

Misurarsi costantemente in modo critico rinnova l'entusiasmo del fare, per questo tecnologia e innovazione sono alla base del nostro lavoro di ogni giorno per ottenere prodotti dallo stile senza tempo creati dalla contaminazione tra materia, colore, forme e geometrie. Lea Ceramiche è la perfetta sintesi di design visionario e performance tecnologica.

Constant critical self assessments renews the enthusiasm for doing, for this reason technology and innovation are the basis of our everyday work, achieving products with timeless style created from the mix of materials, colours, shapes and geometries. Lea Ceramiche is the perfect synthesis of visionary design and technological performance.

Se mesurer constamment de manière critique rénove l'enthousiasme d'accomplir, c'est pourquoi la technologie et l'innovation sont à la base de notre travail de chaque jour afin d'obtenir des produits au style intemporel créés par la contamination entre matière, couleur, formes et géométries. Lea Ceramiche est la synthèse parfaite du design visionnaire et des performances technologiques.

Sich ständig neuen Herausforderungen zu stellen, erneuert die Begeisterung des Tuns, denn diese Technologie und Innovation sind die Basis unserer täglichen Arbeit, um zeitlose Stilprodukte zu schaffen, die durch die Kombination von Materialien, Farben, Formen und Geometrien entstehen. Lea Ceramiche ist die perfekte Synthese aus visionärem Design und technologischer Leistung.

Lea Ceramiche

when creativity meets performance

# Creativity

## visionary design

Lea Ceramiche è partner della creatività ovunque nel mondo per ogni tipo di progetto architettonico che ricerchi distinzione attraverso uno stile unico e riconoscibile.

Lea Ceramiche is the partner of creativity all over in the world for any type of architectural project that seeks distinction through a unique and recognizable style.

Lea Ceramiche est le partenaire de la créativité partout dans le monde pour chaque type de projet architectonique qui recherche distinction à travers un style unique et reconnaissable.

Lea Ceramiche ist weltweit ein Partner für Kreativität und jede Art von architektonischem Projekt, welches sich durch einen einzigartigen und wiedererkennbaren Stil hervorheben möchte.





when creativity meets performance



# Performance

## industrial expertise for technical perfection

Dal concept di design allo sviluppo produttivo delle collezioni, la ricerca della perfezione in Lea Ceramiche si esprime nel segno della massima competenza tecnica, di una forza industriale di primaria eccellenza e di una continua capacità di innovazione e sviluppo.

From the design concept to the productive development of the collections, the search for perfection at Lea Ceramiche is expressed in the form of the highest technical competence, an industrial strength of primary excellence and a continuous capacity for innovation and development.

Du concept de design au développement productif des collections, la recherche de la perfection chez Lea Ceramiche s'exprime sous le signe de la plus haute compétence technique, d'une force industrielle d'excellence et d'une capacité innovative et de développement constante.

Vom Konzept des Designs bis zur produktiven Entwicklung der Kollektionen: Die Suche nach Perfektion äußert sich bei Lea Ceramiche durch höchste technische Kompetenz, industrielle Stärke primärer Exzellenz und kontinuierliche Innovation und Weiterentwicklung.

Essere visionari significa collaborare con i protagonisti del design internazionale per coglierne le esigenze, interpretarle al meglio e restituire nuova ispirazione.

Being visionary means working with leading figures in international design to understand their needs, interpret them in the best possible manner, and provide them with new inspiration.

Être visionnaires veut dire collaborer avec les grands noms du design international pour intégrer leurs exigences, les interpréter au mieux et apporter une nouvelle inspiration.

Ein Visionär zu sein bedeutet mit den Protagonisten des internationalen Designs zusammenzuarbeiten, um die Bedürfnisse zu erkennen, sie aufs Beste zu interpretieren und neue Inspiration wiederzugeben.

# Inspiring Designers



inspiring designers

# Philippe Nigro



Il designer francese, divide la sua attività fra il paese natale e l'Italia. L'unione delle due rispettive culture è motivo di indagine e sperimentazione e dà carattere progettuale e di ispirazione al suo lavoro, che si modula in scale differenti nel rapporto con aziende diverse. Il lavoro di Philippe Nigro è caratterizzato dalla connessione tra ricerca sperimentale e analisi pragmatica del "savoir-faire" dei committenti con cui lavora. Nella collaborazione con Lea Ceramiche, il designer francese firma la collezione Filigrane: la texture geometrica che si sovrappone a quella naturale, offre una doppia lettura, da semplice imitazione la ceramica si trasforma in materiale "neutro".

The French designer divides his work between his native country France and Italy. The union of these two respective cultures is reason for research and experimentation and imparts design and inspiration to his work, which is modulated on diverse levels when relating with different companies. Philippe Nigro's work is characterized by the connection between experimental research and the pragmatic analysis of the "savoir-faire" of his clients. In his collaboration with Lea Ceramiche, he has created the Filigrane collection: this geometric texture overlaps natural ones, which can be read in two ways: from a simple imitation, ceramic tiles become "neutral" material.

Le designer français partage son activité entre son pays natal et l'Italie. Le choc de ces deux cultures est une opportunité unique, permettant au designer d'expérimenter et de mener des recherches, pour donner à ses projets du caractère, une direction, et de les doter de cette capacité de s'adapter à différentes destinations d'usage. Le travail de Philippe Nigro est caractérisé par la connexion entre le domaine expérimental et l'analyse pragmatique du savoir-faire des maîtres d'ouvrage avec qui il travaille. Lors de sa collaboration avec Lea Ceramiche, le designer français a laissé sa touche personnelle en signant la collection Filigrane : la surface naturelle arbore des formes géométriques qui reproduisent la texture de la céramique pour se transformer en matériau « neutre ».

Der französische Designer teilt sein Geschäft zwischen seiner Heimat und Italien. Die Vereinigung der beiden jeweiligen Kulturen ist eine Frage der Erforschung und des Experimentierens und verleiht seiner Arbeit Design und Inspiration, die sich in verschiedenen Skalen in der Beziehung zu verschiedenen Unternehmen moduliert. Die Arbeit von Philippe Nigro zeichnet sich durch die Verbindung zwischen experimenteller Forschung und pragmatischer Analyse des "Savoir-faire" der Auftraggeber aus, mit denen er arbeitet. In Zusammenarbeit mit Lea Ceramiche signiert der französische Designer die Kollektion Filigrane: Die geometrische Textur, die sich mit der natürlichen überlappt, bietet eine doppelte Lesbarkeit; aus der einfacher Imitation der Keramik wird ein "neutrales" Material.

È attraverso il tratto che Patrick Norguet si avvicina al design e agli oggetti. Per il designer francese, il design è, in primo luogo, la storia di un incontro: ciò che gli interessa di più è lo scambio con i produttori, la scoperta delle loro esperienze, lo slancio di un intento creativo affinato dai vincoli della tecnica, la sfida economica e le aspettative di un cliente che lui spera, anche se discretamente, di sedurre per sempre. Il tratto contraddistingue e percorre anche tutte le collezioni che il designer francese firma per Lea Ceramiche: Lines, Waves, Naive e Pad evocano una rete di segni grafici che sulle grandi lastre ceramiche determinano prodotti con un'estetica delicata ma dinamica.

It is through lines that Patrick Norguet approaches design and objects. Interior design for this French designer is first and foremost the story of an encounter. What interests him most is an exchange with the manufacturers, discovering their experiences, this momentum of a creative intent refined by the constraints of technology, the economic challenge, and the expectations of a client that he hopes, even if discreetly, to captivate forever. The line is a distinguishing feature and it is also found throughout all the collections that Norguet has created for Lea Ceramiche: Lines, Waves, Naive, and Pad evoke a network of graphic streaks that, on large ceramic slabs, create products with a delicate but dynamic aesthetic.

Patrick Norguet aime interpréter le design et les objets à travers le pouvoir des traits. Pour lui, le design c'est avant tout un lieu de rencontre, où il est possible de communiquer avec d'autres producteurs qui grâce à leur expérience et à leur créativité ont su pallier les éventuels problèmes techniques et économiques susceptibles de miner leurs projets, pour satisfaire aux attentes des clients les plus exigeants et sophistiqués. Le trait donc, s'impose et parcourt toutes les collections de Lea Ceramiche signées par la main du designer français : Lines, Waves, Naive et Pad lancent ainsi leur filet sur de grandes dalles en céramique, pour attraper la beauté en toute délicatesse, mais avec la juste fermeté.

Patrick Norguet nähert sich Design und Objekten über lineare Muster. Für den französischen Designer ist Design vor allem die Geschichte eines Treffens: Was ihn am meisten interessiert, ist der Austausch mit den Produzenten, die Entdeckung derer Erfahrungen, die Dynamik einer kreativen Absicht, verfeinert durch die Zwänge der Technologie, die wirtschaftliche Herausforderung und die Erwartungen eines Kunden, den er hofft immer, wenn auch diskret, für sich zu gewinnen. Das lineare Merkmal unterscheidet und umfasst auch alle Kollektionen, die der französische Designer für Lea Ceramiche entworfen hat: Lines, Waves, Naive und Pad beschwören ein Netzwerk von grafischen Zeichen, die auf den großen Keramikplatten Produkte mit einer zarten, aber dynamischen Ästhetik bestimmen.



# Patrick Norguet



inspiring designers

# Diego Grandi



Photo credits: Helenio Barbeta

DGO\_Diego Grandi Office è lo studio di progettazione che si occupa di product, interior ed exhibition design. L'attenzione all'aspetto visivo e superficiale del progetto caratterizza e determina la ricerca di Diego Grandi sul valore epidermico dei materiali e sulle possibili declinazioni e contaminazioni di genere. L'indagine sui nuovi codici dell'abitare, incentrata sull'osservazione di comportamenti e abitudini quotidiane, guida il suo atteggiamento nei confronti della superficie e sul valore profondo di progetti a due dimensioni. Questo suo orientamento diventa forma nelle collezioni disegnate per Lea Ceramiche: City, Mauk, Streets in Shade e Type 32, espressioni della visionarietà artistica del designer, in grado di tradurre il materiale ceramico in vero elemento di arredo.

DGO\_Diego Grandi Office is the design studio that specializes in product, exhibition and interior design. An attention to the visual and external aspect of a project characterizes and defines the research carried out by Diego Grandi on the value of the surface of materials and on the possible variations and contaminations of the genre. Research on new living styles, focused on observing daily behaviours and habits, guides his perspective when it comes to surfaces and the profound importance of two-dimensional projects. This approach of his takes shape in the collections he designed for Lea Ceramiche: City, Mauk, Streets in Shade, and Type 32, expressions of the designer's artistic visionary quality, are capable of transforming ceramics into true furnishing accessories.

DGO\_Diego Grandi Office est un studio qui se consacre à la création de produits, d'intérieurs et d'expositions de design. Pour chacun de ses projets, Diego Grandi porte une attention particulière aux détails visuels et aux surfaces, émanant d'une recherche minutieuse de la valeur épidermique pour mieux comprendre les infinies possibilités d'utilisations et de combinaisons des matériaux employés. Pour donner à ses projets cette semblance bidimensionnelle conférée par la valeur profonde de la surface, Diego s'intéresse aux nouvelles manières d'habiter, se focalisant sur les comportements et les habitudes quotidiennes des personnes. Cette étude a permis ainsi de donner forme aux collections spécialement conçues pour Lea Ceramiche : City, Mauk, Streets in Shade et Type 32, expriment le côté visionnaire et artistique du designer, et sont capables de transformer le matériau céramique en véritable élément de décoration.

DGO\_Diego Grandi Office ist das Designstudio, das sich mit Produkt-, Innen- und Ausstellungsdesign beschäftigt. Die Aufmerksamkeit auf den visuellen und oberflächlichen Aspekt des Projekts charakterisiert und bestimmt die Forschung von Diego Grandi über den epidermalen Wert der Materialien und über die möglichen Variationen und Kontaminationen der Art. Die Studie über neue Lebensregeln, die sich auf das Beobachten alltäglicher Verhaltensweisen und Gewohnheiten konzentriert, bildet seinen Leitfaden gegenüber der Oberflächen und den Wert von zweidimensionalen Projekten. Diese Orientierung nimmt in den Kollektionen für Lea Ceramiche Gestalt an: City, Mauk, Streets in Shade und Type 32, Ausdrucksformen der künstlerischen Vision des Designers, der das keramische Material in ein echtes Einrichtungsstück verwandeln kann.

Musicista di successo da oltre 20 anni ma soprattutto icona di stile, Lenny Kravitz fonda nel 2003 Kravitz Design Inc. con l'obiettivo di portare la sua energia creativa al di fuori del mondo musicale. Con sede a New York nel quartiere di SoHo, lo stile Kravitz Design è poliedrico e ricercato, si esprime attraverso l'utilizzo di materiali pregiati, di texture non convenzionali per una nuova eleganza classica degli spazi. Con Goccia disegnata per Lea Ceramiche, Kravitz offre una personale e contemporanea interpretazione del decoro tridimensionale: le piccole sculture ceramiche creano molteplici composizioni in cui ogni singolo elemento diventa parte di un tutt'uno.

Over 20 years as a successful musician but, above all, as an icon of style, Lenny Kravitz founded Kravitz Design Inc. in 2003 with the objective of bringing his creative energy out of the world of music. Based in SoHo in New York, Kravitz Design style is multifaceted and sophisticated, expressed through the use of fine materials and unconventional textures for spaces with a new classic elegance. With Goccia, designed for Lea Ceramiche, Kravitz gives us a personal and contemporary interpretation of three-dimensional decor: small ceramic sculptures create multiple compositions where every single element becomes part of a whole.

Lenny Kravitz, musicien de renommée internationale depuis plus de 20 ans et véritable icône de style, a fondé en 2003 Kravitz Design Inc. afin de canaliser la source d'énergie créative et la transférer en dehors du monde de la musique. Kravitz Design, situé à New York dans le quartier de SoHo, exhibe un style recherché et aux multiples facettes. L'expression de son art se fait à travers l'utilisation de matériaux prestigieux et de textures non conventionnelles pour apporter cette touche élégante et classique dans les espaces. La collection Goccia, composée de décors tridimensionnels, que Lenny Kravitz a imaginée pour Lea Ceramiche, est un hymne moderne et intime : les petites sculptures en céramique créent de multiples compositions où tous les éléments sont en parfaite symbiose, pour ne former qu'un.

Lenny Kravitz ist seit über 20 Jahren ein erfolgreicher Musiker und vor allem eine Stilikone. 2003 gründete Lenny Kravitz die Firma Kravitz Design Inc. mit dem Ziel, seine kreative Energie aus der Musikwelt nach außen zu übertragen. Mit Sitz in New York im Bezirk SoHo ist der Stil Kravitz Design facettenreich und anspruchsvoll, was sich in der Verwendung edler Materialien und unkonventioneller Texturen für eine neue klassische Eleganz der Räume ausdrückt. Mit Goccia, das er für Lea Ceramiche entworfen hat, bietet Kravitz eine persönliche und zeitgemäße Interpretation der dreidimensionalen Dekoration: Die kleinen Keramikskulpturen bilden mehrere Kompositionen, in denen jedes einzelne Element Teil eines Ganzen wird.

# Kravitz design





**SPACE FOR LIFE**  
Marco Piva



**YOU & I**  
Fabio Novembre



Zaha Hadid



Fabio Novembre



**TWIRL**  
Zaha Hadid Architects



**ELEPHOUNTAIN**  
Cibic workshop



**CLEAR SWEET FRESH WATER**  
Antonio Citterio and Patricia Viel

# Collaborations

Le capacità prestazionali e la ricercata qualità estetica hanno reso i prodotti Lea Ceramiche straordinariamente apprezzati da numerosi professionisti del panorama internazionale. Le collaborazioni avviate negli anni, hanno dato origine ad importanti realizzazioni sia in architettura che nell'interior. Alcune di queste partnership, inoltre, hanno dato forma, in qualità di exhibition, design, ad installazioni originali ed impattanti - es. *Twirl by Zaha Hadid Architects*, *Clear Sweet Fresh Water by Antonio Citterio e Patricia Viel*, *Elephountain by Cibicworkshop*, *Space for Life by Marco Piva* - veicolando, specie in questi casi, un utilizzo non convenzionale del materiale ceramico nonché la sua assoluta versatilità. Tutti i progetti realizzati finora sono il risultato del dialogo costante tra l'azienda, con il suo know how e la conoscenza esperta del materiale, e l'intelligenza dei professionisti in grado di dare forme sempre nuove a questa opportunità.

High performance levels and refined aesthetic quality, have made Lea Ceramiche products greatly acknowledged by numerous industry experts in the international panorama. These collaborations, over the years, have given rise to important achievements both in architecture and in interior design. Furthermore, with relation to exhibitions and design, several of these partnerships have given way to original and impactful installations, such as *Twirl by Zaha Hadid Architects*, *Clear Sweet Fresh Water by Antonio Citterio and Patricia Viel*, *Elephountain by Cibicworkshop*, and *Space for Life by Marco Piva*. All these convey an unconventional use for ceramic materials and the absolute versatility they offer. All the projects that have been implemented are the result of a constant dialogue between the company - with its know-how and its expert knowledge of the materials used - and the intelligence of industry experts that are able to give new life to this opportunity.

Si Lea Ceramiche est si appréciée par de nombreux professionnels du monde entier, c'est parce que ses produits font preuve d'une beauté impalpable, d'une qualité inouïe et de performances imbattables. Cette année, la société a noué de nouveaux liens, en créant des collaborations desquelles découlent d'importants projets d'architecture et d'interior design. Et certains de ces partenariats ont d'ailleurs donné naissance à des aménagements originaux et de grand impact, en matière de design et d'exposition (comme *Twirl by Zaha Hadid Architects*, *Clear Sweet Fresh Water by Antonio Citterio et Patricia Viel*, *Elephountain by Cibicworkshop*, *Space for Life by Marco Piva*) démontrant que la céramique ne connaît aucune limite d'utilisation. Tous ces projets sont le résultat d'un dialogue constant entre la société qui met à disposition ses connaissances et son savoir-faire en la matière, et les professionnels qui usent de leur intelligence et de leur maîtrise pour donner forme à cette opportunité.

Die Leistungsfähigkeit und die raffinierte ästhetische Qualität haben dazu geführt, dass die Produkte von Lea Ceramiche von zahlreichen Fachleuten der internationalen Bühne besonders geschätzt werden. Die im Laufe der Jahre begonnenen Zusammenarbeiten haben wichtige Errungenschaften sowohl in der Architektur als auch bei der Inneneinrichtung hervorgebracht. Einige dieser Partnerschaften finden sich in Form von originellen und eindrucksvollen Realisierungen für Ausstellungen und Design wieder - wie zum Beispiel *Twirl by Zaha Hadid Architects*, *Clear Sweet Fresh Water by Antonio Citterio e Patricia Viel*, *Elephountain by Cibicworkshop*, *Space for Life by Marco Piva* - wobei besonders in diesen Fällen eine eher unkonventionelle Verwendung des Keramikmaterials in ihrer absoluten Vielseitigkeit gezeigt wird. Alle bisher durchgeführten Projekte sind das Ergebnis eines ständigen Dialogs zwischen dem Unternehmen mit seinem Know-how und dem Fachwissen über das Material einerseits und der Intelligenz der Fachleute andererseits, die stets in der Lage sind, diesem Material immer neue Formen zu geben. grado di dare forme sempre nuove a questa opportunità.

# Innovation for top Architecture

L'innovazione nel design, l'assoluta affidabilità delle prestazioni tecniche e la capacità di osare e guardare sempre avanti hanno reso Lea Ceramiche una protagonista indiscussa dell'architettura internazionale. Come testimoniato dalla prestigiose referenze realizzate in tutto il mondo.

Innovative design, absolute reliability of technical performance, and the capacity to dare and focus on the future have made Lea Ceramiche an undisputed key player in international architecture. As proved by the important projects supplied by the brand around the world.

L'innovation dans le design, la fiabilité absolue des performances techniques et la capacité à oser et à toujours aller de l'avant ont fait de Lea Ceramiche un protagoniste incontestable de l'architecture internationale. Comme en témoignent les importantes références dans le monde.

Die Innovation im Design, die absolute Zuverlässigkeit der technischen Leistung und die Fähigkeit zu wagen und immer nach vorne zu schauen hat Lea Ceramiche zu einem unangefochtenen Protagonisten der internationalen Architektur gemacht. Wie die Referenzen von renommierten Stellen aus der ganzen Welt beweisen.





**OKKO HOTEL**  
Paris



**CASA MILAN**  
Milano  
Project Studio Fabio Novembre



**BOSCO VERTICALE**  
Milano  
Project Stefano Boeri Gianandrea Barreca  
e Giovanni la Varra



**CHANGI INTERNATIONAL AIRPORT**  
Singapore



# Showrooms & Events

Dallo showroom di Milano al temporary Lab di Parigi, passando per gli eventi e le installazioni di impatto e suggestione in tutto il mondo, Lea Ceramiche dialoga in modo costante e vivace con il mondo del design.

From its showroom in Milan to its temporary Lab in Paris to its evocative installations and its participation in the most influential events around the world, Lea Ceramiche is engaged in a constant and animated dialogue with the world of design.

Du showroom de Milan au temporary Lab de Paris, en passant par les événements et les installations d'impact et de suggestion dans le monde entier, Lea Ceramiche dialogue de manière constante avec le monde du design.

Vom Showroom in Mailand bis zum temporären Lab in Paris, über die Events und bedeutenden und eindrucksvollen Installationen auf der ganzen Welt, Lea Ceramiche steht in einem ständigen und lebendigen Dialog mit der Welt des Designs.



# Il Nostro Gruppo

OUR GROUP



**LEA**  
CERAMICHE

**COTTOD'ESTE**  
Nuovo Superfici

 **FIORDO**

**Blustyle**  
by COTTOD'ESTE

**MARGRES**  
CERAMIC TILES

**LOVE**  
CERAMIC TILES

floridatile

**Bellissimo**  
STILE ITALIANO

# PANARIAGROUP. NEL TEMPO E NEL MONDO, L'ECCELLENZA CERAMICA

THROUGHOUT TIME AND AROUND  
THE WORLD, CERAMIC EXCELLENCE

Eccellere, nel mondo della ceramica di alta qualità, significa saper generare sempre prodotti a elevata componente tecnologica e impreziosirli con la massima attenzione estetica, con la cura di ogni dettaglio. Per soddisfare al meglio i gusti della fascia più elevata ed esigente del mercato, **Panariagroup** adotta da sempre la formula dell'eccellenza, unendo storica sapienza artigianale e attitudine all'avanguardia tecnologica. Con un impegno fondamentale ad agire e operare sempre con responsabilità.

Con oltre 40 anni di esperienza, **Panariagroup** è oggi una realtà internazionale con un cuore fortemente italiano, presente con 9 brand in oltre 120 paesi nel mondo grazie a una vasta e capillare rete commerciale.

To excel in the world of high quality ceramics means knowing how to continuously create highly technological products and how to enhance them through the utmost attention to aesthetics and detail. **Panariagroup** has always adhered to the highest standards of excellence, combining its history of skilful artisan craftsmanship with cutting edge technology. This approach is intrinsically linked to a fundamental commitment to always act and operate responsibly.

With over 40 years of experience, **Panariagroup** is an international company with a strong Italian soul and an extensive sales network with 9 brands in over 120 countries all over the world.

**PANARIA**group®

[www.panariagroup.it](http://www.panariagroup.it)



TOP SPONSOR

A hand is shown from the bottom, holding a thin, white rectangular object horizontally. The background is a soft-focus image of a sunset over water, with a gradient from dark brown at the bottom to light grey at the top. A white rectangular frame is superimposed over the center of the image, containing the text.

# LA RESPONSABILITÀ OLTRE LA SUPERFICIE

RESPONSIBILITY  
BELOW THE SURFACES



Panariagroup realizza prodotti che incontrano la vita quotidiana di milioni di persone nel mondo, nelle case e negli ambienti pubblici; nasce da qui l'impegno fondamentale e imprescindibile a operare con responsabilità.

Da sempre all'avanguardia nel coniugare in modo sapiente bellezza, qualità e sostenibilità, Panariagroup si impegna quotidianamente per ridurre l'impatto ambientale dei suoi prodotti e stabilimenti. Per il Gruppo, inoltre, il principio dell'agire nel rispetto della sostenibilità abbraccia anche politiche e pratiche che coinvolgono e regolano gli impatti dell'organizzazione, a livello sia economico sia sociale.

Per conoscere di più sull'impegno e sulle iniziative concrete di Panariagroup, è possibile consultare il Bilancio di Sostenibilità 2016, scaricabile qui [www.panariagroup.it](http://www.panariagroup.it) o richiedibile via mail a [sustainability@panariagroup.it](mailto:sustainability@panariagroup.it)

Panariagroup manufactures products that are a part of the lives of millions of people all over the world, in homes and public spaces; this is the basis for the company's fundamental and essential commitment to operating responsibly.

Always at the forefront in its knowledge of combining beauty, quality and sustainability, Panariagroup makes every effort to reduce the environmental impact of its products and plants. For the Group, the principle of sustainability also embraces policies and practices that involve and govern the impacts of the organisation, both economically and socially.

To find out more about Panariagroup's commitment and specific initiatives, you can refer to the Sustainability Report 2016, which can be downloaded here at [www.panariagroup.it](http://www.panariagroup.it) or requested via email at [sustainability@panariagroup.it](mailto:sustainability@panariagroup.it)





# Lastre ceramiche ultrasottili in grande formato

## ULTRA-THIN CERAMIC SLABS IN LARGE SIZE

DALLES EN GRÈS CÉRAME ULTRA ÉTHER EN GRANDE FORMAT / ULTRADÜNNE KERAMISCHE PLATTEN IN GROSSER GRÖSSE

Slimtech è la superficie universale per l'architettura: sottile, resistente con l'esclusivo rinforzo di fibra di vetro, versatile e facile da utilizzare. Con l'estensione dei suoi grandi formati consente un risultato straordinario in termini di bellezza e fascino negli spazi e nelle realizzazioni architettoniche. Disponibile negli spessori 3,5 e 5,5 mm, Slimtech è leggero, planare, flessibile, semplice da utilizzare, installare e pulire: un prodotto di eccellenza, con straordinari aspetti estetici di superficie, che nasce da un processo produttivo innovativo, da materie prime di pregio, e dall'esperienza ultradecennale di Lea Ceramiche sui materiali sottili. Un materiale unico, ad elevata sostenibilità grazie al minore impiego di materie prime e ai minori impatti ambientali nel ciclo di produzione e trasporto, e dalle molteplici possibilità di applicazione: non solo pavimenti e rivestimenti ma anche mobili, complementi, cucine e piani di lavoro, pareti ventilate, rivestimenti di gallerie e grandi opere.

Slimtech is the universal surface for architecture: thin, durable with the exclusive fiberglass reinforcement, versatile and easy to use. With the extension of its large formats it gives an extraordinary result in terms of beauty and charm in spaces and architectural designs. Available in thicknesses 3.5 and 5.5 mm, Slimtech is light, planar, flexible, easy to use, install and clean: a product of excellence, with extraordinary aesthetic aspects of the surface, which is born from an innovative production process, from raw materials of high quality, and from the ultra-annual experience of Lea Ceramiche on thin materials. A unique material with high sustainability due to less use of raw materials and minor environmental impacts in the production and transportation cycle and the many possibilities of application: not only floor coverings but also furniture, complements, kitchens and worktops, ventilated walls, galleries and large works.

Slimtech est la surface universelle pour l'architecture: mince, durable avec le renfort en fibre de verre exclusif, polyvalent et facile à utiliser. Avec l'extension de ses grands formats, il donne un résultat extraordinaire en termes de beauté et de charme dans les espaces et les conceptions architecturales. Disponible en épaisseurs de 3,5 et 5,5 mm, Slimtech est léger, planaire, flexible, facile à utiliser, à installer et à nettoyer: un produit d'excellence aux aspects esthétiques extraordinaires de la surface, né d'un processus de production innovant, à partir de matériaux qualité supérieure, et l'expérience ultradecennale de Lea Ceramiche sur les matériaux minces. Un matériau unique à haute durabilité grâce à une moindre utilisation de matières premières et des impacts environnementaux mineurs dans le cycle de production et de transport et aux nombreuses possibilités d'application: non seulement les revêtements de sol mais aussi les meubles, les compléments, les cuisines et les plans de travail, murs ventilés, galeries et grands travaux.

Slimtech ist die universelle Oberfläche für Architektur: dünn, langlebig mit der exklusiven Glasfaserverstärkung, vielseitig und einfach zu bedienen. Mit der Erweiterung seiner großen Formate gibt es ein außergewöhnliches Ergebnis in Bezug auf Schönheit und Charme in Räumen und architektonischen Entwürfen. Mit seinen Stärken von 3,5 und 5,5 mm ist Slimtech leicht, eben, flexibel, einfach zu verwenden, zu installieren und zu reinigen: ein Produkt von hervorragender Qualität mit außergewöhnlichen ästhetischen Aspekten der Oberfläche, geboren aus einem innovativen Produktionsprozess, aus Materialien Top-Qualität und die ultra-dezente Erfahrung von Lea Ceramiche auf dünnen Materialien. Ein einzigartiges Material mit hoher Nachhaltigkeit durch weniger Rohstoffeinsatz und geringen Umweltbelastungen im Produktions- und Transportkreislauf und den vielfältigen Einsatzmöglichkeiten: nicht nur Bodenbeläge, sondern auch Möbel, Ergänzungen, 4 Küchen und Arbeitsplatten, belüftete Wände, Galerien und große Werke

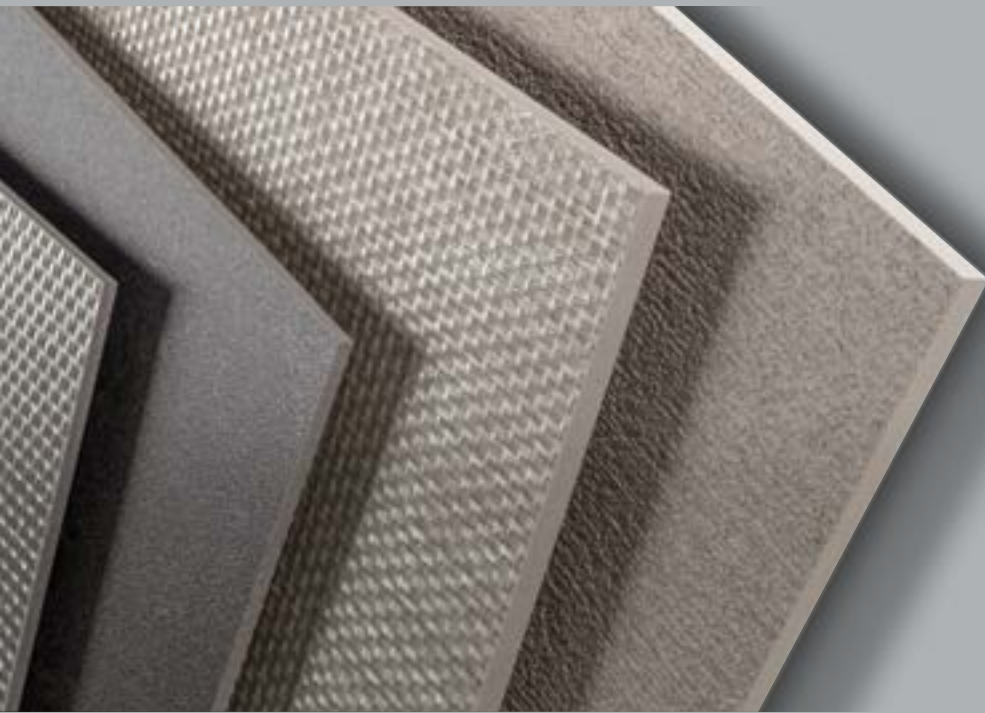

# Slimtech: due spessori per infinite applicazioni

## TWO THICKNESSES FOR INFINITE APPLICATIONS

DEUX ÉPAISSEURS POUR DES APPLICATIONS INFINIES / ZWEI DICKEN FÜR UNENDLICHE ANWENDUNGEN



Ideale per pavimenti e rivestimenti in ambito residenziale e commerciale leggero, sia per nuove costruzioni che per ristrutturazioni con posa in sovrapposizione a pavimenti preesistenti.

Ideal flooring and wall cladding in residential and light commercial spaces, both for new construction and renovations with tiling laid on pre-existing floors.

Idéal pour les revêtements de sol et muraux résidentiels et commerciaux légers, tant pour les nouveaux bâtiments que pour les rénovations avec des planchers qui se chevauchent aux planchers existants.

Ideal für leichte Wohn- und Gewerbeböden und Wandverkleidungen, sowohl für Neubauten als auch für Renovierungen mit überlappenden Böden zu bestehenden Fußböden.



Ideale anche per la posa in ambienti commerciali soggetti a traffico intenso, sia per nuove costruzioni che per ristrutturazioni con posa in sovrapposizione a pavimenti preesistenti.

It is also ideal for installation in commercial environments subject to heavy traffic, both for new buildings and for renovation projects with tiling laid on pre-existing floors.

Il est également idéal pour la pose dans les zones commerciales soumises à un trafic intense, à la fois pour les nouveaux bâtiments et pour les rénovations avec des planchers qui se chevauchent aux planchers existants.

Es ist auch ideal für die Verlegung in gewerblich genutzten Bereichen mit starkem Verkehrsaufkommen, sowohl für Neubauten als auch für Renovierungen mit überlappenden Etagen zu bestehenden Etagen.

# Una tecnologia sostenibile che riduce l'impatto ambientale

## A SUSTAINABLE TECHNOLOGY THAT REDUCES THE ENVIRONMENTAL IMPACT

UNE TECHNOLOGIE DURABLE QUI RÉDUIT L'IMPACT ENVIRONNEMENTAL  
EINE NACHHALTIGE TECHNOLOGIE, DIE DIE UMWELTBELASTUNG VERRINGERT

Slimtech è frutto di un processo produttivo unico ed ecocompatibile: meno materie prime utilizzate, minor consumo di acqua ed energia e minori emissioni di CO<sub>2</sub>

Slimtech is the result of a unique and ecologically productive process: less raw materials used, less water and energy consumption and lower CO<sub>2</sub> emissions.

Slimtech est le résultat d'un processus unique et écologiquement productif: moins de matières premières utilisées, moins de consommation d'eau et d'énergie et moins d'émissions de CO<sub>2</sub>

Slimtech ist das Ergebnis eines einzigartigen und ökologisch produktiven Prozesses: weniger eingesetzte Rohstoffe, weniger Wasser- und Energieverbrauch sowie weniger CO<sub>2</sub> Emissionen

### CARTA DI IDENTITÀ AMBIENTALE

ENVIRONMENTAL IDENTITY CARD / ENVIRONMENTAL IDENTITY CARD / ENVIRONMENTAL IDENTITY CARD

#### SLIMTECH 3PLUS

GRES PORCELLANATO LAMINATO RINFORZATO CON FIBRA DI VETRO  
LAMINATED PORCELAIN STONEWARE REINFORCED WITH FIBREGLASS

 **3,5 mm**  
SPESSORE / THICKNESS **-65%**

 **7,8 kg/m<sup>2</sup>**  
PRODOTTO FINITO  
FINISHED PRODUCT **-65%**

 **65 l/m<sup>2</sup>**  
FABBISOGNO D'ACQUA  
WATER REQUIRED **-80%**

 **190 MJ/m<sup>2</sup>**  
FABBISOGNO DI ENERGIA  
ENERGY REQUIRED **-30%**

 **14,1 kgCO<sub>2</sub>/m<sup>2</sup>**  
CO<sub>2</sub> EMESSA IN ATMOSFERA  
CO<sub>2</sub> EMITTED IN THE ATMOSPHERE **-30%**

 **3840** <sup>m<sup>2</sup>/camion</sup>  
<sup>m<sup>2</sup>/truck</sup>  
INCIDENZA DEL TRASPORTO  
TRANSPORT FACTOR **-66%**

#### 10 MM

GRES PORCELLANATO GENERICO  
GENERIC PORCELAIN STONEWARE

**10 mm**  
SPESSORE / THICKNESS

**24 kg/m<sup>2</sup>**  
PRODOTTO FINITO  
FINISHED PRODUCT

**309 l/m<sup>2</sup>**  
FABBISOGNO D'ACQUA  
WATER REQUIRED

**275 MJ/m<sup>2</sup>**  
FABBISOGNO DI ENERGIA  
ENERGY REQUIRED

**20,6 kgCO<sub>2</sub>/m<sup>2</sup>**  
CO<sub>2</sub> EMESSA IN ATMOSFERA  
CO<sub>2</sub> EMITTED IN THE ATMOSPHERE

**1280** <sup>m<sup>2</sup>/camion</sup>  
<sup>m<sup>2</sup>/truck</sup>  
INCIDENZA DEL TRASPORTO  
TRANSPORT FACTOR



# Gres Porcellanato ad alto spessore

HIGH THICKNESS PORCELAIN STONEWARE  
GRÈS CÉRAME À HAUTE ÉPAISSEUR / GLASIERTES FEINSTEINZEUG MIT HOHER STÄRKE

## 20mm

Le collezioni System L2 di Lea Ceramiche spessore 20mm uniscono qualità estetica ed elevate prestazioni tecniche garantendo infinite applicazioni in esterno senza preoccupazioni di rottura. Resistenti al gelo e agli sbalzi termici presentano elevate caratteristiche antiscivolo e sono facili da pulire mantenendo inalterati nel tempo materia e colore.

Lea Ceramiche's System L2 collections, 20mm thick, combine aesthetic quality and high technical performance, guaranteeing endless outdoor applications without any worries about breaking. Resistant to frost and thermal changes, they have high anti-slip characteristics and are easy to clean with the material and color remaining unaltered over time.

Les collections System L2 de Lea Ceramiche épaisseur 20 mm unissent qualité esthétique et prestations techniques élevées garantissant d'infinies applications en extérieur sans préoccupations de ruptures. Résistantes au gel et aux chocs thermiques, elles présentent des caractéristiques antidérapantes élevées et sont faciles à nettoyer tout en maintenant inaltérées dans le temps, matière et couleur.

Die Kollektionen System L2 von Lea Ceramiche mit einer Dicke von 20 mm kombinieren ästhetische Qualität und hohe technische Leistung und garantieren endlose Anwendungen im Außenbereich, ohne sich Sorgen um einen Bruch machen zu müssen. Frost- und temperaturbeständig, haben die Fliesen eine hohe Rutschfestigkeit und sind leicht zu reinigen. Material und Farbe bleiben im Laufe der Zeit unverändert.





# Decors and accessories

Guardare oltre, corredando le superfici ceramiche di ricercati innesti decorativi e applicazioni raffinate, per un tratto distintivo in grado di dare sempre una personalità esclusiva ad ogni collezione Lea Ceramiche.

Looking beyond, pairing ceramic surfaces featuring refined decorative inserts with elegant applications, for a characteristic quality that gives every Lea Ceramiche collection a unique personality.

Regarder au-delà, en dotant les surfaces céramiques de greffages décoratifs recherchés et d'applications raffinées, pour un trait distinctif capable de toujours donner une personnalité exclusive à chaque collection Lea Ceramiche.

Immer einen Schritt voraus, mit Keramikoberflächen, die sich durch ausgesuchte dekorative Elemente und raffinierte Applikationen auszeichnen, für ein unverwechselbares Merkmal, die jeder Kollektion von Lea Ceramiche eine exklusive Persönlichkeit verleiht.

( )



**LEA**

CERAMICHE

[www.protect.panariagroup.it](http://www.protect.panariagroup.it)

# P R ( ) T E C T

L'esclusiva tecnologia Panariagroup per pavimenti e rivestimenti antibatterici ad altissime performance. Per un abitare sano, sicuro e protetto.

The exclusive Panariagroup technology for floor and wall coverings with the highest performance. To live healthy, safe and secure.

La technologie exclusive de Panariagroup pour les revêtements de sols et de murs antibactériens à hautes performances. Pour un habitat sain, sûr et protégé.

Die exklusive Technologie Panariagroup für antibakterielle und hochleistungsfähige Fußböden und Verkleidungen. Für ein gesundes, sicheres und geschütztes Wohnen.



## AZIONE POTENTE

elimina i batteri e ne impedisce la proliferazione

## ACTION PUISSANTE

élimine les bactéries et empêche leur prolifération

## POWERFUL ACTION

eliminates microbes and prevents their reproduction

## LEISTUNGSSTARKE WIRKUNG

eliminiert Bakterien und verhindert die Vermehrung



## PROTEZIONE CONTINUA

sempre attivo, 24 ore su 24, con e senza luce solare

## PROTECTION CONTINUE

toujours actif, 24 heures sur 24, avec et sans lumière du soleil

## CONTINUOUS PROTECTION

always active, 24 hours a day, with and without sunlight

## DAUERSCHUTZ

rund um die Uhr aktiv, mit oder ohne Sonnenlicht



## EFFICACIA ETERNA

grazie alla tecnologia integrata in modo permanente nel prodotto

## EFFICACITÉ ÉTERNELLE

grâce à la technologie intégrée de façon permanente dans le produit

## ETERNAL EFFECTIVENESS

thanks to the technology permanently integrated into the product

## DAUERHAFTE WIRKSAMKEIT

dank der permanent im Produkt integrierten Technologie



## QUALITÀ GARANTITA

dalla partnership con MICROBAN®

## QUALITÉ GARANTIE

du partenariat avec MICROBAN®

## GUARANTEED QUALITY

by the partnership with MICROBAN®

## GARANTIERTE QUALITÄT

dank der Partnership mit MICROBAN®

Slimtech è la soluzione che completa il progetto di superfici di Lea Ceramiche offrendo lastre di dimensioni oversize abbinate ad una straordinaria leggerezza. È il frutto di una tecnologia di laminazione e compattazione del gres porcellanato che rivoluziona il processo produttivo tradizionale ed ottiene così un prodotto completamente nuovo, resistente, leggero, flessibile, duttile e versatile. Slimtech soddisfa pienamente le esigenze più attuali della moderna progettazione sia per interni che per le ampie superfici esterne degli edifici contemporanei. È facile da installare e risolve, meglio di qualunque altro materiale, le problematiche del rinnovo offrendo risultati estetici eccellenti.

Slimtech is the solution that completes Lea Ceramiche's collection of products for surfaces, offering oversized slabs that are extraordinarily lightweight. It is the fruit of a lamination and compaction technology for porcelain stoneware that revolutionizes the traditional manufacturing process, thus creating a completely new, resistant, lightweight, flexible, ductile and versatile product. Slimtech fully satisfies the today's demands of modern design, both for interiors and for large exterior surfaces of contemporary buildings. It's easy to install and solves, better than any other material, renovation issues, providing excellent aesthetic results.

Slimtech est la solution innovante en matière de surfaces qui complète le projet de Lea Ceramiche en proposant des dalles XXL dotées d'une extrême légèreté. Grâce à une technologie innovante de laminage et de compactage du grès cérame, qui révolutionne ainsi le processus traditionnel de production, nous avons donné naissance à un produit entièrement innovant, résistant, léger, flexible, souple et universel. Slimtech satisfait pleinement aux exigences les plus actuelles de conception moderne d'intérieurs et de grandes surfaces d'extérieur des bâtiments contemporains. Son installation est simple et résout, mieux que tout autre matériau, les problèmes liés à la rénovation, offrant des résultats d'une excellence esthétique.

Slimtech mit ihren überdimensional großen und außergewöhnlich leichten Platten ist die Lösung, die das Projekt der Oberflächen von Lea Ceramiche ergänzt. Slimtech ist das Ergebnis einer Laminierungs- und Verdichtungstechnologie für Feinsteinzeug, die das traditionelle Herstellungsverfahren revolutioniert, mit dem Erhalt eines völlig neuen, langlebigen, leichten, biegsamen und vielseitigen Produkts. Slimtech erfüllt in vollem Umfang die Anforderungen des heutigen modernen Design für die weitreichenden Innen- und Außenflächen der zeitgenössischen Gebäude. Es ist leicht zu verlegen und löst dank des Erhalts hervorragender ästhetischer Ergebnisse besser als jedes andere Material die bei der Renovierung auftretenden Problematiken.

- 46 contemporary  
**TAKE CARE AND PAD** design Patrick Norguet
- 62  
**ABSOLUTE**
- 68  
**RE-EVOLUTION**
- 76  
**GOUACHE.10 AND LIBECCIO** design Diego Grandi
- 82  
**SHADE AND STREETS** design Diego Grandi
- 88 stone  
**WATERFALL**
- 96  
**BASALTINA STONE PROJECT**
- 106 marble  
**TIMELESS MARBLE AND FILIGRANE** design Philippe Nigro
- 124 wood  
**WOOD-STOCK**
- 134  
**TYPE 32** design Diego Grandi
- 146 shapes & colors  
**NAIVE** design Patrick Norguet
- 154  
**LINES AND WAVES** design Patrick Norguet
- 166  
**NEST** design HOK Product Design
- 170  
**MAUK** design Diego Grandi
- 
- 176  
**LEA LAB**
- 178  
**DESTINAZIONI D'USO**

## GRES LAMINATO

Laminated porcelain / Grès laminé / Laminiertes Feinsteinzeug

### SLIMTECH 3plus

# 3,5 mm

## SLIMTECH 3PLUS

rinforzata con stuoia in fibra di vetro, per rivestimenti e pavimenti / reinforced with a sheet of fiberglass, for wall and floor applications / renforcé au dos par une natte en fibre de verre, pour revêtements sols et murs / mit Glasfasermatte verstärkt, Für Wand und Boden geeignet /

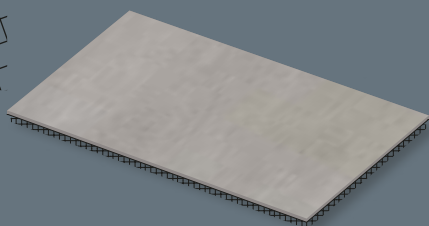

### SLIMTECH 5plus

# 5,5 mm

## SLIMTECH 5PLUS

rinforzata con stuoia in fibra di vetro, per rivestimenti e pavimenti ad alto traffico / reinforced with a sheet of fiberglass, for wall cladding and high traffic floor applications / renforcé au dos par une natte en fibre de verre, pour revêtements de sols au passage intensif et de murs / mit Glasfasermatte verstärkt, für Wand stark frequentierte Böden geeignet /

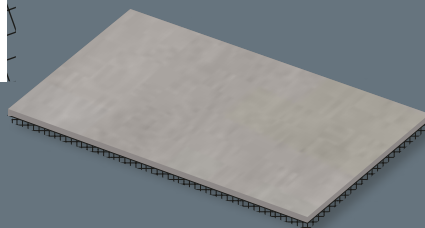

## FORMATI (CM)

Sizes - Formats - Formate

	100x300	100x150	50x150	100x100	50x100	4,9x100	33x300	20x200	20x150	20x100
<b>Absolute</b>	•			•						
<b>Basaltina Stone P.</b>	•			•	•	•				
<b>Gouache.10</b>	•			•	•	•				
<b>Lines</b>	•									
<b>Naive</b>	•			•						
<b>Re-evolution</b>	•			•	•	•				
<b>Shade</b>	•			•	•	•				
<b>Take Care</b>	•	•		•						
<b>Timeless Marble</b>	•		•	•						
<b>Type 32</b>								•		
<b>Waterfall</b>	•			•	•					
<b>Waves</b>	•									
<b>Wood-stock</b>							•	•	•	•



contemporary

**TAKE CARE  
and PAD**  
design  
Patrick Norguet



**T\_STEEL**  
100x100cm / 39"x39"



**C\_STEEL**  
100x300cm / 39"x118"

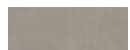

**PAD OAKLAND  
SNOW**  
100x300cm / 39"x118"





# TAKE CARE

and PAD design Patrick Norguet

**S**LIMTECH | **P R ( ) T E C T**  
ANTIBATTERICO - ANTIMICROBIAL

spessore / thickness **5,5mm**

**3**  
**FORMATI**  $LRT^{\square}$   
sizes / formats / Formate

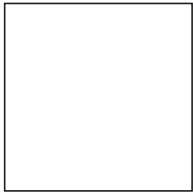

100x100cm / 39"x39"  
slimtech 5plus  
TAKE

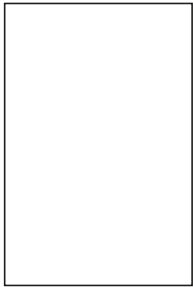

100x150cm / 39"x58"  
slimtech 5plus  
CARE

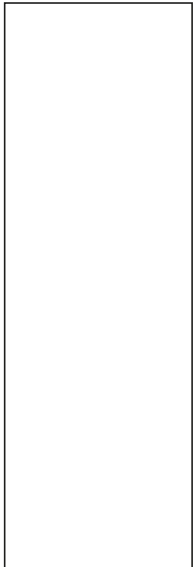

100x300cm / 39"x118"  
slimtech 5plus  
TAKE CARE

**2**  
**FINITURE**  
finishes / surfaces / Oberfläche

**TAKE**  
**CARE**

**5**  
**COLORI**  
colors / couleurs / Farben





## TAKE CARE

48/  
49



**T\_SNOW**  
100x300cm / 39"x118"

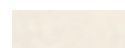

**T\_STEEL**  
100x300cm / 39"x118"



**T\_NIGHT**  
100x300cm / 39"x118"



# TAKE CARE



**T\_GROUND**  
100x100cm / 39"x39"



**PAD OAKLAND  
GROUND**  
100x300cm / 39"x118"





contemporary



# TAKE CARE

## C\_NIGHT

100x150 cm / 39"x58"

100x300cm / 39"x118"



## C\_GROUND

100x150 cm / 39"x58"



## C\_STEEL

100x300cm / 39"x118"



contemporary







## TAKE CARE

54/  
55

**C\_MOON**  
100x300cm / 39"x118"



contemporary

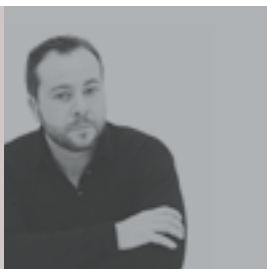

# TAKE CARE PAD

design  
Patrick Norguet

## OAKLAND\*



### FORMATO

size / format / Format

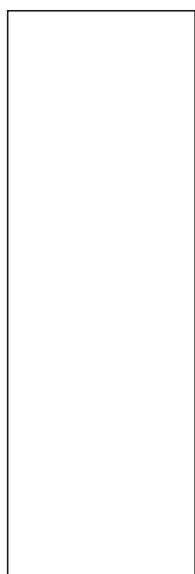

100x300cm / 39"x118"  
slimtech 5plus

Oakland  
snow



Oakland  
moon



\* Utilizzabile solo a RIVESTIMENTO / Suitable only for WALL COVERINGS  
Seulement pour les REVÊTEMENTS / Nur zur VERKLEIDUNG verwendbar

LEA CERAMICHE

Oakland  
steel



Oakland  
ground



Oakland  
night





# TAKE CARE PAD

design  
Patrick Norguet

## TAMIS\*

### Tamis snow A - B - C



### Tamis moon A - B - C



### Tamis steel A - B - C

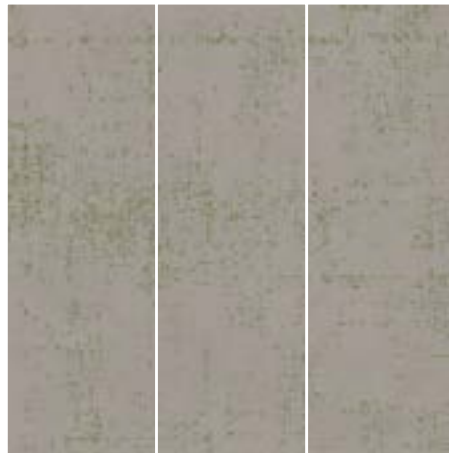

### Tamis ground A - B - C

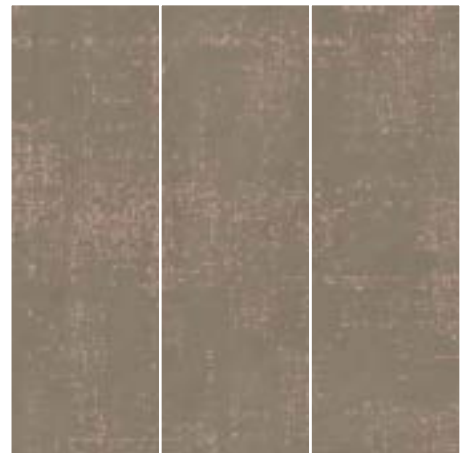

### Tamis night A - B - C

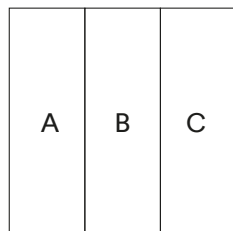

\* Utilizzabile solo a RIVESTIMENTO / Suitable only for WALL COVERINGS  
Seulement pour les REVÊTEMENTS / Nur zur VERKLEIDUNG verwendbar

A



B



C



# TAKE CARE



**TAKE CARE****GRES PORCELLANATO LAMINATO UGL**

Laminated porcelain stoneware UGL / Grès laminé UGL / Laminiertes Feinsteinzeug UGL

**SPESSORE**

Thickness / Epaisseur / Stärke

5,5 mm → slimtech 5plus

**STONALIZZAZIONE**

Shading / Denuançage / Spielfarbig

**ANSI A137.3**

**PAD - Informazioni tecniche per l'utilizzo pag. 370**

Technical information for use.

Informations techniques pour l'utilisation.

Technische Zusammenarbeit.

**RESISTENZA ALLO SCIVOLAMENTO**

Slip resistance / Résistance au glissement

Rutschfestigkeit

**DIN 51130**

R9

**BCR-TORTUS**

$\mu > 0,40$

**ANSI A326.3**

DCOF  $\geq 0.42$

**FUGA MINIMA CONSIGLIATA**

Minimum suggested joint

Joint minimum conseillé

Empfohlene Fugenbreite

**POSA A PARETE** / Wall / Mur / Wand

1 mm (INDOOR) → slimtech 5plus

**POSA A PAVIMENTO** / Floor / Sol / Boden

2 mm (INDOOR) → slimtech 5plus

**OUTDOOR**

vedi Manuale Tecnico Slimtech

see Slimtech Technical Manual

**LEGENDA CODICI PRODOTTO / IMBALLI**

Legend product codes / Packing

Légende codes produits / Emballage

Legend Produktcodes / Verpackung

pag. 387/388

**P R ( ) T E C T**

ANTIBATTERICO - ANTIMICROBIAL

**PAD TAMIS  
MOON**

100x300cm / 39"x118"

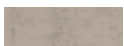

contemporary



**TOTAL BLACK**  
100x300cm / 39"x118"  
lev



**TOTAL WHITE**  
100x100cm / 39"x39"  
sat

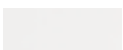



# ABSOLUTE

**S**LIMTECH | **P R ( ) T E C T**  
ANTIBATTERICO - ANTIMICROBIAL

spessore / thickness **5,5mm**

**2**

**FORMATI**  $\text{LRT}^{\text{T}}$

sizes / formats / Formate

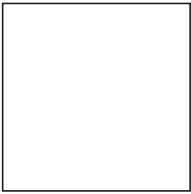

100x100cm / 39"x39"  
slimtech 5plus



100x300cm / 39"x118"  
slimtech 5plus

**2**

**FINITURE**

finishes / surfaces / Oberfläche

**LEV**

**SAT**

**2**

**COLORI**

colors / couleurs / Farben

**Total White**

**Total Black**



I  
AB EFGH  
J LMNOPQ  
ST VWXY  
Zabcd efgh  
I nopp q r  
sxyz 123456  
7890000000

# ABSOLUTE

## TOTAL WHITE

100x300cm / 39"x118"

sat

100x100cm / 39"x39"

sat

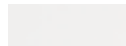

## TOTAL BLACK

100x100cm / 39"x39"

sat





# ABSOLUTE

## TOTAL WHITE

100x300cm / 39"x118"  
lev

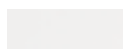

# ABSOLUTE

66/  
67

## GRES PORCELLANATO LAMINATO UGL

Laminated porcelain stoneware UGL / Grès laminé  
UGL / Laminierter Feinsteinzeug UGL

### SPESSORE

Thickness / Epaisseur / Stärke

5,5 mm → slimtech 5plus



### STONALIZZAZIONE

Shading / Denuançage / Spielfarbig

ANSI A137.3

### FINITURA LEV

Lev surface finish / Finition LEV

LEV Oberfläche

**Ideale per rivestimenti e per pavimenti in ambienti residenziali.**

Suitable for wall coverings and floors in residential applications.

Idéal pour revêtements et sols pour locaux résidentiels privés.

Für Wand und Boden im Wohnbereich geeignet.

### FINITURA SAT

Sat surface finish / Finition SAT

SAT Oberfläche

**Ideale per rivestimenti e per pavimenti in ambienti residenziali e commerciale leggero.**

Suitable for wall coverings and floors in both residential and light-commercial applications.

Idéal pour revêtements et sols pour locaux résidentiels privés et commercial léger.

Für Wand und Boden im Wohn- und leichte kommerzielle Bereiche geeignet / Ideal para.

### FUGA MINIMA CONSIGLIATA

Minimum suggested joint

Joint minimum conseillé

Empfohlene Fugenbreite

**POSA A PARETE** / Wall / Mur / Wand

1 mm (INDOOR) → slimtech 5plus

**POSA A PAVIMENTO** / Floor / Sol / Boden

2 mm (INDOOR) → slimtech 5plus

### OUTDOOR

vedi Manuale Tecnico Slimtech

see Slimtech Technical Manual

### RESISTENZA ALLO SCIVOLAMENTO

Slip resistance / Résistance au glissement

Rutschfestigkeit

**ANSI A326.3**

DCOF ≥ 0.42 (Sat)

### LEGENDA CODICI PRODOTTO / IMBALLI

Legend product codes / Packing

Légende codes produits / Emballage

Legend Produktcodes / Verpackung

pag. 382

### P R ( ) T E C T

ANTIBATTERICO - ANTIMICROBIAL

contemporary



**SRC030**  
100x300cm / 39"x118"



**SRC010**  
100x100cm / 39"x39"



# RE-EVOLUTION

 **LIMTECH**

spessore / thickness **3,5mm**

**4**

**FORMATI** 

sizes / formats / Formate

**6**

**COLORI**

colors / couleurs / Farben



4,9x100cm / 2"x39"  
slimtech 3plus



50x100cm / 19<sup>1</sup>/<sub>2</sub>"x39"  
slimtech 3plus

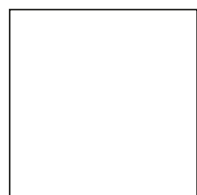

100x100cm / 39"x39"  
slimtech 3plus

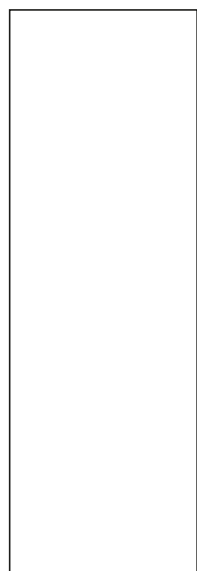

100x300cm / 39"x118"  
slimtech 3plus

**SRC010**

**SRW010**

**SRC020**

**SRW020**

**SRC030**

**SRW030**





# RE-EVOLUTION

70/  
71



**SRW020**  
100x100cm / 39"x39"



contemporary

# RE-EVOLUTION



**SRC020**  
100x300cm / 39"x118"





# RE-EVOLUTION



## RE-EVOLUTION

### GRES PORCELLANATO LAMINATO UGL

Laminated porcelain stoneware UGL / Grès laminé UGL / Laminiertes Feinsteinzeug UGL

#### SPESSORE

Thickness / Epaisseur / Stärke

3,5 mm → slimtech 3plus



#### STONALIZZAZIONE

Shading / Denuançage / Spielfarbig

ANSI A137.3

#### FUGA MINIMA CONSIGLIATA

Minimum suggested joint

Joint minimum conseillé

Empfohlene Fugenbreite

**POSA A PARETE** / Wall / Mur / Wand

1 mm (INDOOR) → slimtech 5plus

**POSA A PAVIMENTO** / Floor / Sol / Boden

2 mm (INDOOR) → slimtech 5plus

#### OUTDOOR

vedi Manuale Tecnico Slimtech

see Slimtech Technical Manual

#### LEGENDA CODICI PRODOTTO / IMBALLI

Legend product codes / Packing

Légende codes produits / Emballage

Legend Produktcodes / Verpackung

pag. 386



#### SRC020

100x300cm / 39"x118"



#### SRW010

100x100cm / 39"x39"



contemporary

**GOUACHE.10  
and LIBECCIO**  
design  
Diego Grandi



**CRYSTAL WATER**  
100x300cm / 39"x118"

100x100cm / 39"x39"



# GOUACHE.10

and LIBECCIO design Diego Grandi

 SLIMTECH

spessore / thickness **3,5mm**

**4**

**FORMATI** 

sizes / formats / Formate

**7**

**COLORI**

colors / couleurs / Farben



4,9x100cm / 2"x39"  
slimtech 3plus



50x100cm / 19<sup>1</sup>/<sub>2</sub>"x39"  
slimtech 3plus



100x100cm / 39"x39"  
slimtech 3plus

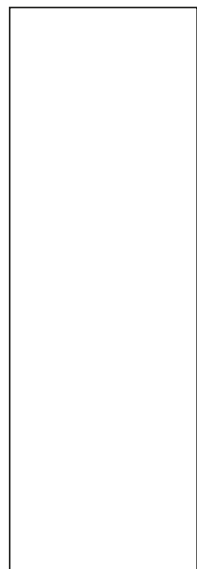

100x300cm / 39"x118"  
slimtech 3plus

White Cloud

Crystal Water

Soft Sand

Deep Sea

Light Rock

Cool Rain

Black Stone

contemporary







# GOUACHE.10

78/  
79

**DEEP SEA**  
100x100cm / 39"x39"



contemporary



# GOUACHE.10 LIBECCIO

design  
Diego Grandi



**DECORI**

decors / decors / dekore

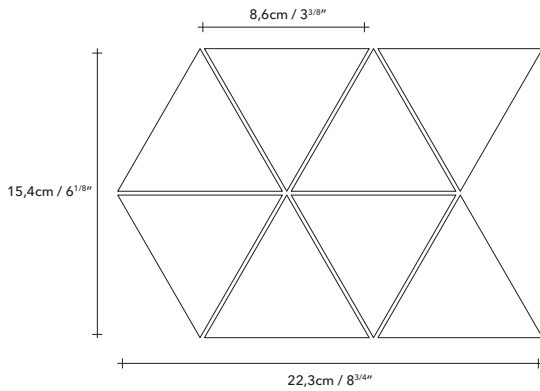

**LIBECCIO**  
white cloud  
15,4x22,3cm / 6 1/8"x8 3/4"



**LIBECCIO**  
crystal water  
15,4x22,3cm / 6 1/8"x8 3/4"



**LIBECCIO 01**  
warm  
15,4x22,3cm / 6 1/8"x8 3/4"



**LIBECCIO**  
soft sand  
15,4x22,3cm / 6 1/8"x8 3/4"



**LIBECCIO**  
cool rain  
15,4x22,3cm / 6 1/8"x8 3/4"



**LIBECCIO 01**  
cold  
15,4x22,3cm / 6 1/8"x8 3/4"



**LIBECCIO**  
light rock  
15,4x22,3cm / 6 1/8"x8 3/4"



**LIBECCIO**  
deep sea  
15,4x22,3cm / 6 1/8"x8 3/4"



**LIBECCIO 02**  
15,4x22,3cm / 6 1/8"x8 3/4"



**LIBECCIO**  
black stone  
15,4x22,3cm / 6 1/8"x8 3/4"



**LIBECCIO 03**  
15,4x22,3cm / 6 1/8"x8 3/4"

**GOUACHE.10****GRES PORCELLANATO LAMINATO UGL**

Laminated porcelain stoneware UGL / Grès laminé UGL / Laminiertes Feinsteinzeug UGL

**SPESSORE**

Thickness / Epaisseur / Stärke

3,5 mm → slimtech 3plus

**STONALIZZAZIONE**

Shading / Denuançage / Spielfarbig

**ANSI A137.3****FUGA MINIMA CONSIGLIATA**

Minimum suggested joint

Joint minimum conseillé

Empfohlene Fugenbreite

**POSA A PARETE** / Wall / Mur / Wand

1 mm (INDOOR) → slimtech 3plus

**POSA A PAVIMENTO** / Floor / Sol / Boden

2 mm (INDOOR) → slimtech 3plus

**OUTDOOR**

vedi Manuale Tecnico Slimtech

see Slimtech Technical Manual

**RESISTENZA ALLO SCIVOLAMENTO**

Slip resistance / Résistance au glissement

Rutschfestigkeit

**DIN 51130****R9****BCR-TORTUS** $\mu > 0,40$ **ANSI A326.3****DCOF  $\geq 0.42$** **LEGENDA CODICI PRODOTTO / IMBALLI**

Legend product codes / Packing

Légende codes produits / Emballage

Legend Produktcodes / Verpackung

pag. 383/384

contemporary

**SHADE  
and STREETS**  
design  
Diego Grandi



**MILK**  
100x300cm / 39"x118"

100x100cm / 39"x39"



# SHADE

and STREETS design Diego Grandi

 SLIMTECH

spessore / thickness **3,5mm**

**4**

**FORMATI** 

sizes / formats / Formate

**2**

**COLORI**

colors / couleurs / Farben



4,9x100cm / 2"x39"  
slimtech 3plus



50x100cm / 19<sup>1</sup>/<sub>2</sub>"x39"  
slimtech 3plus

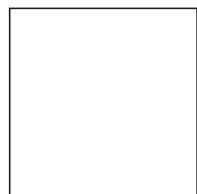

100x100cm / 39"x39"  
slimtech 3plus

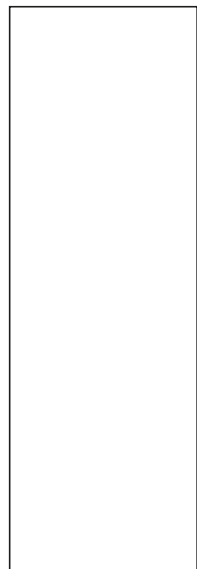

100x300cm / 39"x118"  
slimtech 3plus

Milk

Black Coffee

contemporary

# SHADE

**MILK**

100x300cm / 39"x118"

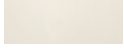

**BLACK COFFEE**

100x300cm / 39"x118"

100x100cm / 39"x39"







# SHADE STREETS

design  
Diego Grandi

STREETS KYOTO  
50X100cm / 19<sup>1</sup>/<sub>2</sub>"X39"



STREETS MELBOURNE  
50X100cm / 19<sup>1</sup>/<sub>2</sub>"X39"



**STREETS  
MELBOURNE**  
50x100cm / 19<sup>1</sup>/<sub>2</sub>"x39"



## SHADE

### GRES PORCELLANATO LAMINATO UGL

Laminated porcelain stoneware UGL / Grès laminé UGL / Laminiertes Feinsteinzeug UGL

### SPESSORE

Thickness / Epaisseur / Stärke

3,5 mm → slimtech 3plus



### STONALIZZAZIONE

Shading / Denuançage / Spielfarbig

ANSI A137.3

### FUGA MINIMA CONSIGLIATA

Minimum suggested joint

Joint minimum conseillé

Empfohlene Fugenbreite

**POSA A PARETE** / Wall / Mur / Wand

1 mm (INDOOR) → slimtech 3plus

**POSA A PAVIMENTO** / Floor / Sol / Boden

2 mm (INDOOR) → slimtech 3plus

### OUTDOOR

vedi Manuale Tecnico Slimtech

see Slimtech Technical Manual

### RESISTENZA ALLO SCIVOLAMENTO

Slip resistance / Résistance au glissement

Rutschfestigkeit

**DIN 51130**

R9

**BCR-TORTUS**

$\mu > 0,40$

**ANSI A326.3**

DCOF  $\geq 0.42$

### LEGENDA CODICI PRODOTTO / IMBALLI

Legend product codes / Packing

Légende codes produits / Emballage

Legend Produktcodes / Verpackung

pag. 386/387

stone



**SILVER FLOW**

100x300cm / 39"x118"

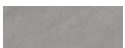

# WATERFALL

**S**LIMTECH | **P R O T E C T**  
ANTIBATTERICO - ANTIMICROBIAL

spessore / thickness **5,5mm**

**3**

**FORMATI** <sup>RT</sup>

sizes / formats / Formate

**4**

**COLORI**

colors / couleurs / Farben



50x100cm / 19<sup>1</sup>/<sub>2</sub>"x39"  
slimtech 5plus

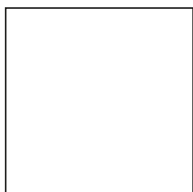

100x100cm / 39"x39"  
slimtech 5plus

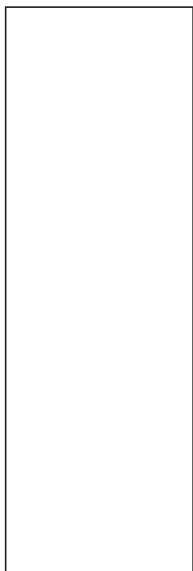

100x300cm / 39"x118"  
slimtech 5plus

Ivory flow

Silver flow

Gray flow

Dark flow

stone

# WATERFALL

## GRAY FLOW

100x100cm / 39"x39"  
nat



## DARK FLOW

100x300cm / 39"x118"  
nat



## GRAY FLOW

100x100cm / 39"x39"  
nat









# WATERFALL

92/  
93

**GRAY FLOW**  
100x100cm / 39"x39"  
nat



**IVORY FLOW**  
100x100cm / 39"x39"  
nat

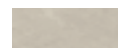

**DARK FLOW**  
100x300cm / 39"x118"  
nat







# WATERFALL

## NEST IVORY FLOW

ettagono  
L 25cm / 10"  
50x43,5cm / 19<sup>1</sup>/<sub>2</sub>"x17"

triangolo  
L 25cm / 10"

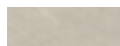

**DARK FLOW**  
60x120cm / 24"x48"  
lapp rett.

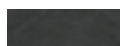

## WATERFALL

94/  
95

### GRES PORCELLANATO LAMINATO UGL

Laminated porcelain stoneware UGL / Grès laminé  
UGL / Laminiertes Feinsteinzeug UGL

### SPESSORE

Thickness / Epaisseur / Stärke  
5,5 mm → slimtech 5plus



### STONALIZZAZIONE

Shading / Denuançage / Spielfarbig

ANSI A137.3

### FUGA MINIMA CONSIGLIATA

Minimum suggested joint  
Joint minimum conseillé  
Empfohlene Fugenbreite

**POSA A PARETE** / Wall / Mur / Wand  
1 mm (INDOOR) → slimtech 5plus

**POSA A PAVIMENTO** / Floor / Sol / Boden  
2 mm (INDOOR) → slimtech 5plus

### OUTDOOR

vedi Manuale Tecnico Slimtech  
see Slimtech Technical Manual

### RESISTENZA ALLO SCIVOLAMENTO

Slip resistance / Résistance au glissement  
Rutschfestigkeit

**DIN 51130**

R10

**BCR-TORTUS**

μ>0,40

**ANSI A326.3**

DCOF ≥ 0.42

### LEGENDA CODICI PRODOTTO / IMBALLI

Legend product codes / Packing  
Légende codes produits / Emballage  
Legend Produktcodes / Verpackung

pag. 390

### P R ( ) T E C T

ANTIBATTERICO - ANTIMICROBIAL

stone



**NATURALE**

100x300cm / 39"x118"

100x100cm / 39"x39"



**LAPPATA**

50x100cm / 19<sup>1</sup>/<sub>2</sub>"x39"

4,9x100cm / 2"x39"



# BASALTINA STONE PROJECT

 SLIMTECH

spessore / thickness **3,5mm**

**4**

**FORMATI** 

sizes / formats / Formate

**4**

**COLORI**

colors / couleurs / Farben



4,9x100cm / 2"x39"  
slimtech 3plus

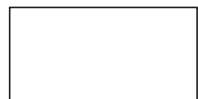

50x100cm / 19<sup>1</sup>/<sub>2</sub>"x39"  
slimtech 3plus

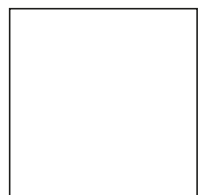

100x100cm / 39"x39"  
slimtech 3plus

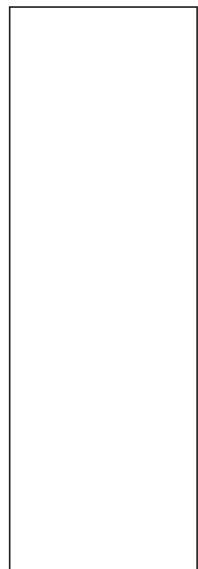

100x300cm / 39"x118"  
slimtech 3plus



# BASALTINA STONE PROJECT



## NATURALE

100x300cm / 39"x118"

100x100cm / 39"x39"

mosaico striscia  
25x50cm / 10"x19<sup>1/2</sup>"



## LAPPATA

100x300cm / 39"x118"









# BASALTINA STONE PROJECT

100/  
101

## STUCCATA

100x300cm / 39"x118"

100x100cm / 39"x39"

mosaico striscia  
25x50cm / 10"x19<sup>1/2</sup>"

mosaico listello  
25x50cm / 10"x19<sup>1/2</sup>"



## NATURALE

50x100cm / 19<sup>1/2</sup>"x39"

100x100cm / 39"x39"



# BASALTINA STONE PROJECT

## MOSAICI

mosaics / mosaïques / Mosaik

MOSAICO  
QUADRO  
sabbiaia  
25x25cm /  
10"x10"

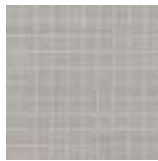

MOSAICO  
MATTONE  
sabbiaia  
25x25cm /  
10"x10"



MOSAICO  
STRISCIA  
sabbiaia  
25x50cm /  
10"x19 1/2"



MOSAICO  
LISTELLO  
sabbiaia  
25x50cm /  
10"x19 1/2"



MOSAICO  
QUADRO  
naturale  
25x25cm /  
10"x10"

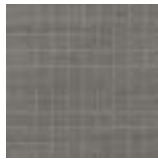

MOSAICO  
MATTONE  
naturale  
25x25cm /  
10"x10"



MOSAICO  
STRISCIA  
naturale  
25x50cm /  
10"x19 1/2"



MOSAICO  
LISTELLO  
naturale  
25x50cm /  
10"x19 1/2"



MOSAICO  
QUADRO  
stuccata  
25x25cm /  
10"x10"

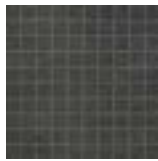

MOSAICO  
MATTONE  
stuccata  
25x25cm /  
10"x10"



MOSAICO  
STRISCIA  
stuccata  
25x50cm /  
10"x19 1/2"



MOSAICO  
LISTELLO  
stuccata  
25x50cm /  
10"x19 1/2"



MOSAICO  
QUADRO  
lappata  
25x25cm /  
10"x10"



MOSAICO  
MATTONE  
lappata  
25x25cm /  
10"x10"

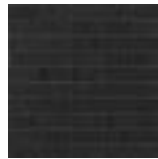

MOSAICO  
STRISCIA  
lappata  
25x50cm /  
10"x19 1/2"

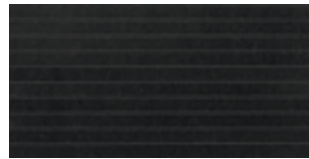

MOSAICO  
LISTELLO  
lappata  
25x50cm /  
10"x19 1/2"





## MOSAICI

mosaics / mosaïques / Mosaik

MOSAICO  
INOX  
sabbata  
25x25cm /  
10"x10"



MOSAICO  
SATIN  
sabbata  
25x25cm /  
10"x10"



MOSAICO  
METAL  
chiaro (naturale)  
50x100cm /  
19 1/2"x39"



MOSAICO  
GLITTER  
chiaro (sabbata)  
50x100cm /  
19 1/2"x39"



MOSAICO  
INOX  
naturale  
25x25cm /  
10"x10"



MOSAICO  
SATIN  
naturale  
25x25cm /  
10"x10"



MOSAICO  
INOX  
stuccata  
25x25cm /  
10"x10"

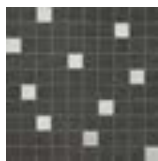

MOSAICO  
PEARL  
stuccata  
25x25cm /  
10"x10"

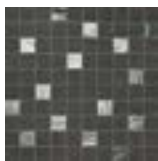

MOSAICO  
METAL  
scuro (lappata)  
50x100cm /  
19 1/2"x39"



MOSAICO  
GLITTER  
scuro (stuccata)  
50x100cm /  
19 1/2"x39"



MOSAICO  
INOX  
lappata  
25x25cm /  
10"x10"

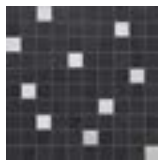

MOSAICO  
PEARL  
lappata  
25x25cm /  
10"x10"

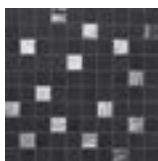



# BASALTINA STONE PROJECT

## SABBIATA

100x300cm / 39"x118"

60x120cm / 24"x48" (11mm)

mosaico mattone  
25x50cm / 10"x19<sup>1</sup>/<sub>2</sub>"



## BASALTINA STONE PROJECT

### GRES PORCELLANATO LAMINATO UGL

Laminated porcelain stoneware UGL / Grès laminé UGL / Laminiertes Feinsteinzeug UGL

### SPESSORE

Thickness / Epaisseur / Stärke

3,5 mm → slimtech 3plus



### STONALIZZAZIONE

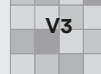

Shading / Denuançage / Spielfarbig

ANSI A137.3

### FUGA MINIMA CONSIGLIATA

Minimum suggested joint

Joint minimum conseillé

Empfohlene Fugenbreite

**POSA A PARETE** / Wall / Mur / Wand

1 mm (INDOOR) → slimtech 5plus

**POSA A PAVIMENTO** / Floor / Sol / Boden

2 mm (INDOOR) → slimtech 5plus

### OUTDOOR

vedi Manuale Tecnico Slimtech

see Slimtech Technical Manual

### RESISTENZA ALLO SCIVOLAMENTO

Slip resistance / Résistance au glissement

Rutschfestigkeit

**DIN 51130**

R9

**BCR-TORTUS**

$\mu > 0,40$

**ANSI A326.3**

DCOF  $\geq 0.42$

### LEGENDA CODICI PRODOTTO / IMBALLI

Legend product codes / Packing

Légende codes produits / Emballage

Legend Produktcodes / Verpackung

pag. 382/383

marble

**TIMELESS MARBLE  
and FILIGRANE**  
design  
Philippe Nigro



**PIETRA GRAY**  
100x300cm / 39"x118"  
sat

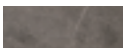

# TIMELESS MARBLE

and FILIGRANE design Philippe Nigro

**S**LIMTECH | **P R ( ) T E C T**  
ANTIBATTERICO - ANTIMICROBIAL

spessore / thickness **5,5mm**

### 3

**FORMATI** <sup>LR<sup>T</sup></sup>

sizes / formats / Formate



50x150cm / 19<sup>1</sup>/<sub>2</sub>"x59"  
slimtech 5plus

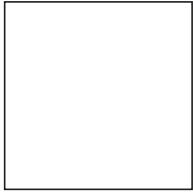

100x100cm / 39"x39"  
slimtech 5plus

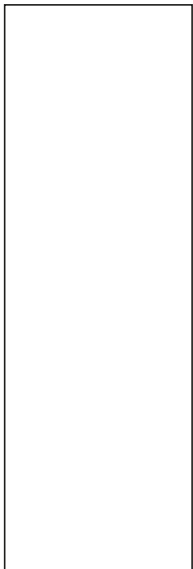

100x300cm / 39"x118"  
slimtech 5plus

### 2

**FINITURE**

finishes / surfaces / Oberfläche

**LEV**

**SAT**

### 7

**COLORI**

colors / couleurs / Farben

Lasa Bright

Onice Venus

Calacatta Gold Extra

Pietra Gray

Safari Amande

Statuario White

Travertino Classico

marble



## TIMELESS MARBLE

### STATUARIO WHITE

100x300cm / 39"x118"

lev

50x150cm / 19 1/2"x59"

lev

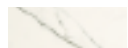



**TRAVERTINO CLASSICO**  
50x150cm / 19<sup>1</sup>/<sub>2</sub>"x59"  
lev



marble

# TIMELESS MARBLE



**ONICE VENUS**  
100x300cm / 39"x118"  
lev

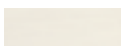





marble



# TIMELESS MARBLE

## CALACATTA GOLD EXTRA

100x100 cm / 39"x39"

lev

100x300cm / 39"x118"

lev



## SAFARI AMANDE

50x150cm / 19<sup>1</sup>/<sub>2</sub>"x59"

lev





## TIMELESS MARBLE

**ONICE VENUS**  
100x100cm / 39"x39"  
sat





**CALACATTA BUTTERFLY**  
100x300cm / 39"x118"  
lev



marble



# TIMELESS MARBLE FILIGRANE

design  
Philippe Nigro





**PEARL  
LASA BRIGHT**  
100x300cm / 39"x118"  
sat



marble







## TIMELESS MARBLE

118 / 119

**HYPHEN  
CALACATTA GOLD EXTRA**

100x300cm / 39"x118"

sat

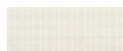

**PEARL  
CALACATTA GOLD EXTRA**

100x300cm / 39"x118"

sat



**HYPHEN  
PIETRA GRAY**  
100x300cm / 39"x118"  
sat





# TIMELESS MARBLE FILIGRANE

design  
Philippe Nigro

## PEARL SAT



### FORMATO

size / format / Format

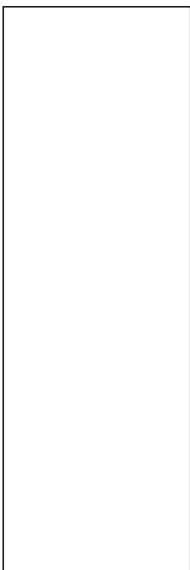

100x300cm / 39"x118"  
slimtech 5plus



**Pearl**  
onice venus



**Pearl**  
lasa bright



**Pearl**  
calacatta gold extra

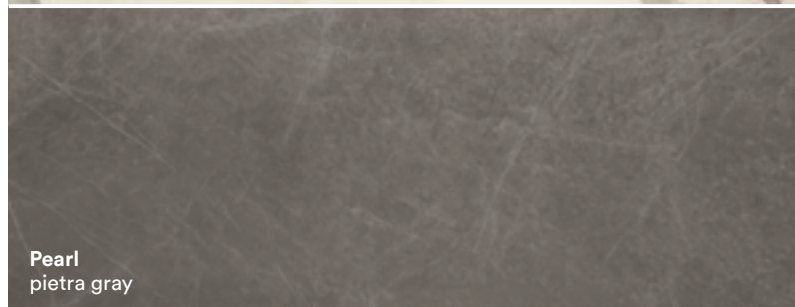

**Pearl**  
pietra gray



**Pearl**  
statuario white

# HYPHEN

## SAT

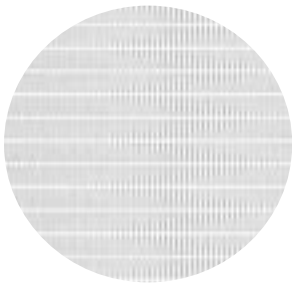

**Hyphen**  
onice venus



**Hyphen**  
lasa bright



**Hyphen**  
calacatta gold extra

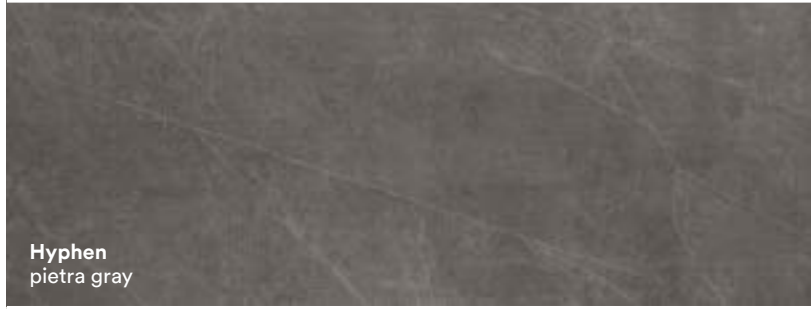

**Hyphen**  
pietra gray



**Hyphen**  
statuario white

### FORMATO

size / format / Format

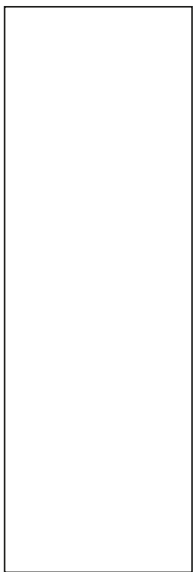

100x300cm / 39"x118"  
slimtech 5plus

# TIMELESS MARBLE BUTTERFLY

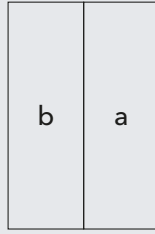

CALACATTA BUTTERFLY B  
100x300cm / 39"x118"



CALACATTA BUTTERFLY A  
100x300cm / 39"x118"



## TIMELESS MARBLE

### GRES PORCELLANATO LAMINATO UGL

Laminated porcelain stoneware UGL / Grès laminé UGL / Laminierter Feinsteinzeug UGL

### SPESSORE

Thickness / Epaisseur / Stärke

5,5 mm → slimtech 5plus



### STONALIZZAZIONE

Shading / Denuançage / Spielfarbig

ANSI A137.3

### FINITURA LEV

Lev surface finish / Finition LEV

LEV Oberfläche

**Ideale per rivestimenti e per pavimenti in ambienti residenziali.**

Suitable for wall coverings and floors in residential applications.

Idéal pour revêtements et sols pour locaux résidentiels privés.

Für Wand und Boden im Wohnbereich geeignet.

### FINITURA SAT

Sat surface finish / Finition SAT

SAT Oberfläche

**Ideale per rivestimenti e per pavimenti in ambienti residenziali e commerciale leggero.**

Suitable for wall coverings and floors in both residential and light-commercial applications.

Idéal pour revêtements et sols pour locaux résidentiels privés et commercial léger.

Für Wand und Boden im Wohn- und leichte kommerzielle Bereiche geeignet / Ideal para.

### FUGA MINIMA CONSIGLIATA

Minimum suggested joint

Joint minimum conseillé

Empfohlene Fugenbreite

**POSA A PARETE** / Wall / Mur / Wand

1 mm (INDOOR) → slimtech 5plus

**POSA A PAVIMENTO** / Floor / Sol / Boden

2 mm (INDOOR) → slimtech 5plus

### OUTDOOR

vedi Manuale Tecnico Slimtech

see Slimtech Technical Manual

### RESISTENZA ALLO SCIVOLAMENTO

Slip resistance / Résistance au glissement

Rutschfestigkeit

**ANSI A326.3**

DCOF ≥ 0.42 (sat)

### LEGENDA CODICI PRODOTTO / IMBALLI

Legend product codes / Packing

Légende codes produits / Emballage

Legend Produktcodes / Verpackung

pag. 388/389

### PROTECT

ANTIBATTERICO - ANTIMICROBIAL

wood



**COFFEE WOOD**  
20x200cm / 8"x79"

Type-32 coffee W 25



# WOOD-STOCK

**S**LIMTECH | **P R ( ) T E C T**  
ANTIBATTERICO - ANTIMICROBIAL

spessore / thickness **5,5mm**

**4**

**FORMATI**  $\text{LRT}^{\text{T}}$

sizes / formats / Formate



20x100cm / 8"x39"  
slimtech 5plus

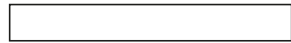

20x150cm / 8"x59"  
slimtech 5plus



20x200cm / 8"x79"  
slimtech 5plus



33x300cm / 13"x118"  
slimtech 5plus

**5**

**COLORI**

colors / couleurs / Farben

**Snow Wood**



**Vintage Wood**



**Cream Wood**



**Coffee Wood**



**Honey Wood**



wood



# WOOD-STOCK

**CREAM WOOD**  
33x300cm / 13" x 118"







wood





## WOOD-STOCK

**SNOW WOOD**  
20x200cm / 8"x79"



wood



# WOOD-STOCK

**VINTAGE WOOD**  
20x150cm / 8"x59"



130/  
131

**HONEY WOOD**  
33x300cm / 13"x118"



wood



# WOOD-STOCK

## COFFEE WOOD

20x200cm / 8"x79"

Type-32 coffee W 25



## WOOD-STOCK

132/  
133

### GRES PORCELLANATO LAMINATO UGL

Laminated porcelain stoneware UGL / Grès laminé UGL / Laminiertes Feinsteinzeug UGL

### SPESSORE

Thickness / Epaisseur / Stärke

5,5 mm → slimtech 5plus



### STONALIZZAZIONE

Shading / Denuançage / Spielfarbig



ANSI A137.3

### FUGA MINIMA CONSIGLIATA

Minimum suggested joint

Joint minimum conseillé

Empfohlene Fugenbreite

**POSA A PARETE** / Wall / Mur / Wand

1 mm (INDOOR) → slimtech 5plus

**POSA A PAVIMENTO** / Floor / Sol / Boden

2 mm (INDOOR) → slimtech 5plus

### OUTDOOR

vedi Manuale Tecnico Slimtech

see Slimtech Technical Manual

### RESISTENZA ALLO SCIVOLAMENTO

Slip resistance / Résistance au glissement

Rutschfestigkeit

**DIN 51130**

R10

**BCR-TORTUS**

$\mu > 0,40$

**ANSI A326.3**

DCOF  $\geq 0.42$

### LEGENDA CODICI PRODOTTO / IMBALLI

Legend product codes / Packing

Légende codes produits / Emballage

Legend Produktcodes / Verpackung

pag. 391

### PROTECT

ANTIBATTERICO - ANTIMICROBIAL

wood

**TYPE 32**  
design  
Diego Grandi

**HONEY**

Beta Warm 11

Delta Cold 30

Alfa Warm 03

Gamma Cold 22





# TYPE 32

design Diego Grandi

 SLIMTECH

spessore / thickness 5,5mm

1

**FORMATO** <sup>RT</sup>

size / format / Formate



20x200cm / 8"x79"  
slimtech 5plus

4

**COLORI**

colors / couleurs / Farben



Snow



Honey



Vintage

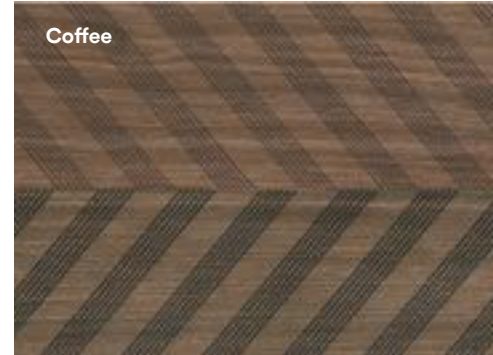

Coffee

wood





## TYPE 32

### SNOW

Delta Warm 28

Delta Cold 29



wood





## TYPE 32

### COFFEE

Delta Cold 32

Delta Warm 25



### HONEY

Beta Warm 11

Delta Cold 30

Alfa Warm 03

Gamma Cold 22



wood



## TYPE 32

**VINTAGE**

Alfa Cold 07

Delta Warm 26







# TYPE 32

design Diego Grandi

**COLORI**  
colors / couleurs / farben

## SNOW

ALFA

BETA

GAMMA

DELTA

05

13

21

29



COLD

04

12

20

28



WARM

## HONEY

ALFA

BETA

GAMMA

DELTA

06

14

22

30

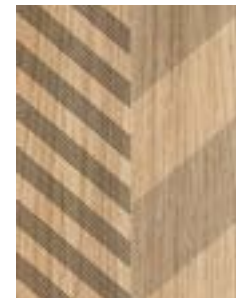

COLD

03

11

19

27

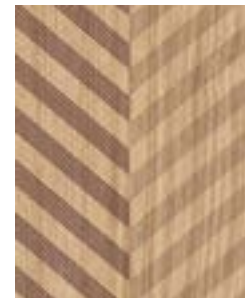

WARM



**COLORI**

colors / couleurs / farben

**VINTAGE**

ALFA

BETA

GAMMA

DELTA

07

15

23

31

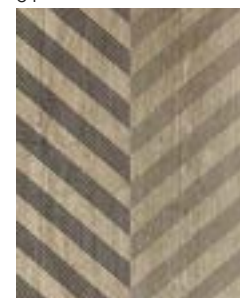

COLD

02

10

18

26



WARM

**COFFEE**

ALFA

BETA

GAMMA

DELTA

08

16

24

32



COLD

01

09

17

25

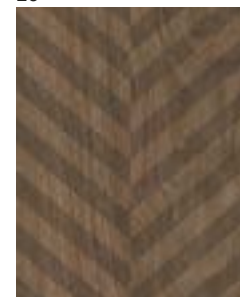
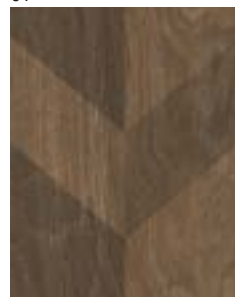
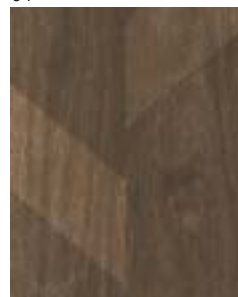

WARM

wood



## TYPE 32

### SNOW

Delta Warm 28

Delta Cold 29



## TYPE 32

### GRES PORCELLANATO LAMINATO UGL

Laminated porcelain stoneware UGL / Grès laminé UGL / Laminiertes Feinsteinzeug UGL



**Type 32 è un progetto per sua natura versatile, in grado di interagire con l'ambiente ed i suoi abitanti e di modificarsi nelle forme e nei colori. Come il legno, anche Type 32, nel registrare il passare del tempo, restituisce una superficie dall'aspetto vintage, un effetto "vissuto" tipico dei pavimenti legati alla nostra memoria. Questa peculiarità rende la collezione originale ed esclusiva, con una personalità irripetibile. In Type 32 i mutamenti rincorrono e ricordano il tempo trascorso.**

Type 32 is a design which, due to its versatile nature, is able to interact with the environment and its inhabitants, as well as change in terms of shapes and colors. Like aged wood, Type 32 also gives an area a vintage look, a "lived in" effect which is typical of floors with a touch of nostalgia. This peculiarity makes the collection unique and original, with a special personality. With Type 32 the changes take us back and remind us of times gone by.

Grâce à sa nature polyvalente, Type 32 est en mesure d'interagir avec l'environnement et ses habitants et de modifier ses propres formes et couleurs. Tel le bois sous l'effet du temps qui passe, Type 32 révèle une surface à l'aspect vintage, avec un effet de « vécu » caractéristique des sols liés à notre mémoire. Cette particularité en fait une collection originale et exclusive, dont la personnalité est incomparable. Avec Type 32, les changements recherchent et évoquent le temps passé.

Type 32 ist ein vielseitiges Projekt, das in der Lage ist, mit der Umwelt und ihren Bewohnern zu interagieren und sowohl Form als auch Farbe zu wechseln. So wie es bei Holz der Fall ist, hinterlässt das Vergehen der Zeit auch bei Type 32 einen Vintage-Look auf der Bodenoberfläche, eine "gelebte" Wirkung, die typisch für Fußböden unserer Erinnerungen ist. Dieser Charakterzug erweist sich als grundlegend für diese originale und exklusive Kollektion unwiderstehlicher Persönlichkeit. Bei Type 32 folgt und gedenkt Wandel der verstrichenen Zeit.

### SPESSORE

Thickness / Epaisseur / Stärke  
5,5 mm → slimtech 5plus



### STONALIZZAZIONE

Shading / Denuançage / Spielfarbig

ANSI A137.3

### Informazioni tecniche per l'utilizzo pag. 370

Technical information for use.  
Informations techniques pour l'utilisation.  
Technische Zusammenarbeit.

### Ideale per rivestimenti e per pavimenti in ambienti residenziali.

Suitable for wall coverings and floors in residential applications.

Idéal pour revêtements et sols pour locaux résidentiels privés.

Für Wand und Boden im Wohnbereich geeignet.

### FUGA MINIMA CONSIGLIATA

Minimum suggested joint  
Joint minimum conseillé  
Empfohlene Fugenbreite

**POSA A PARETE** / Wall / Mur / Wand  
1 mm (INDOOR) → slimtech 5plus

**POSA A PAVIMENTO** / Floor / Sol / Boden  
2 mm (INDOOR) → slimtech 5plus

### OUTDOOR

vedi Manuale Tecnico Slimtech  
see Slimtech Technical Manual

### LEGENDA CODICI PRODOTTO / IMBALLI

Legend product codes / Packing  
Légende codes produits / Emballage  
Legend Produktcodes / Verpackung

pag. 389

**NAIVE**  
design  
Patrick Norguet



**NAIVE BLACK**  
100x300cm / 39"x118"



# NAIVE

design Patrick Norguet

 SLIMTECH

spessore / thickness **5,5mm**

**2**

**FORMATI** 

sizes / formats / Formate

**4**

**COLORI**

colors / couleurs / Farben

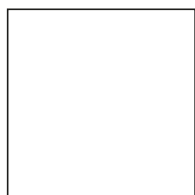

100x100cm / 39"x39"  
slimtech 5plus

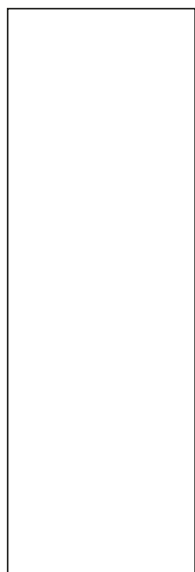

100x300cm / 39"x118"  
slimtech 5plus

**Naive Blue**



**Naive Terra**



**Naive Grey**



**Naive Black**

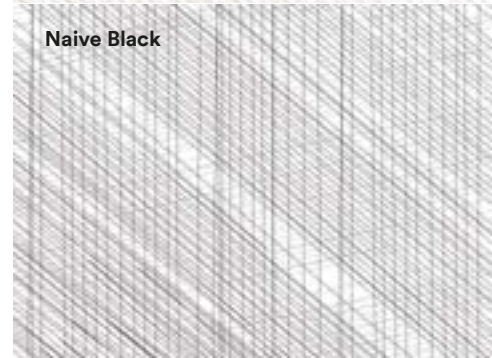



# NAIVE

## NAIVE GREY

100x300cm / 39"x118"



148/  
149



## NAIVE BLUE

100x300cm / 39"x118"







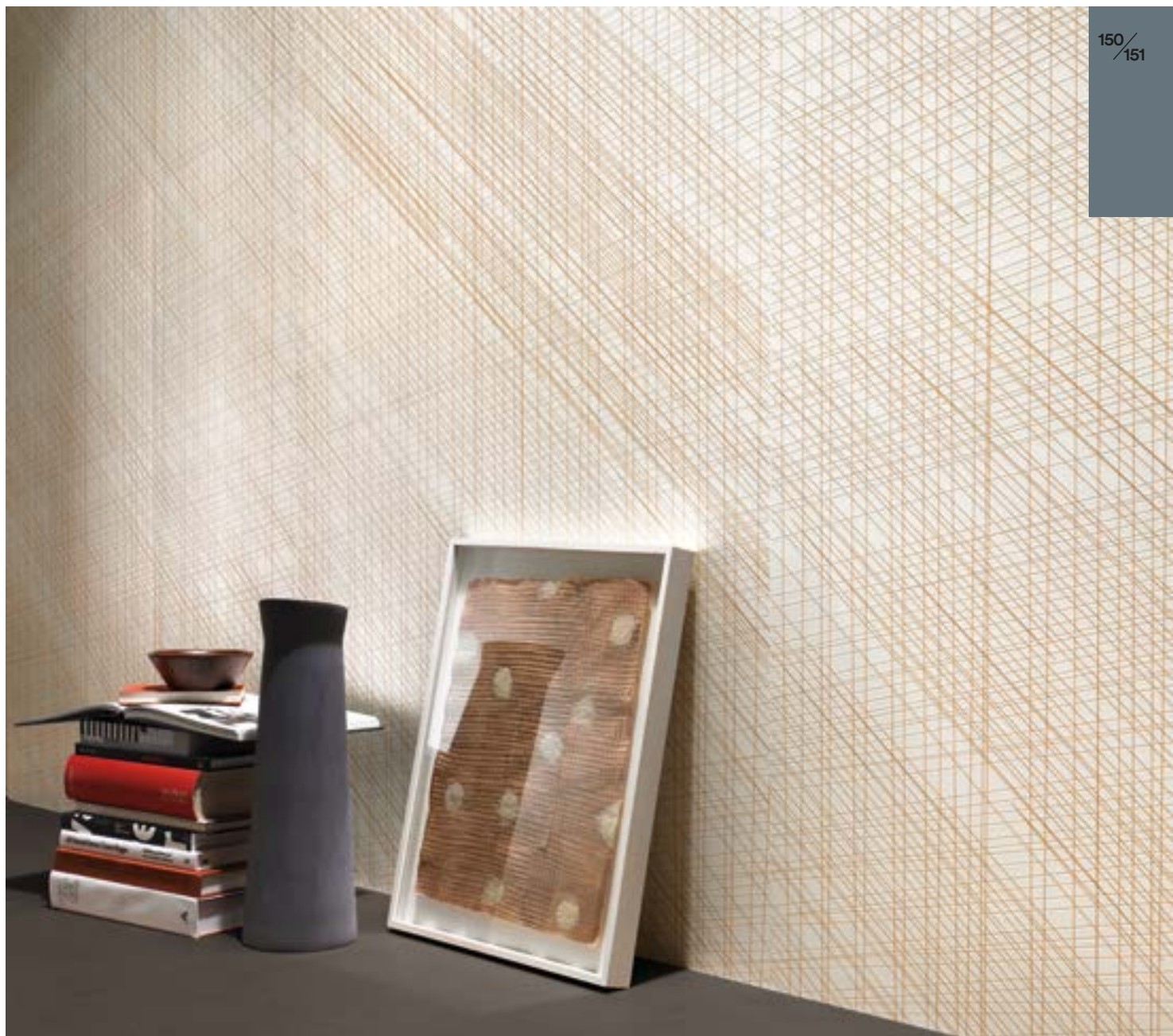

## NAIVE

**NAIVE TERRA**  
100x300cm / 39"x118"





# NAIVE

**NAIVE BLACK**  
100x300cm / 39"x118"



## NAIVE

### GRES PORCELLANATO LAMINATO UGL

Laminated porcelain stoneware UGL / Grès laminé UGL / Laminiertes Feinsteinzeug UGL



### SPESSORE

Thickness / Epaisseur / Stärke

5,5 mm → slimtech 5plus



### STONALIZZAZIONE

Shading / Denuançage / Spielfarbig

ANSI A137.3

### FUGA MINIMA CONSIGLIATA

Minimum suggested joint

Joint minimum conseillé

Empfohlene Fugenbreite

**POSA A PARETE** / Wall / Mur / Wand

1 mm (INDOOR) → slimtech 5plus

**POSA A PAVIMENTO** / Floor / Sol / Boden

2 mm (INDOOR) → slimtech 5plus

### OUTDOOR

vedi Manuale Tecnico Slimtech

see Slimtech Technical Manual

### Ideale per rivestimenti e per pavimenti in ambienti residenziali e commerciale leggero.

Suitable for wall coverings and floors in both residential and light-commercial applications.

Idéal pour revêtements et sols pour locaux résidentiels privés et commercial léger.

Für Wand und Boden im Wohn- und leichte kommerzielle Bereiche geeignet / Ideal para.

### LEGENDA CODICI PRODOTTO / IMBALLI

Legend product codes / Packing

Légende codes produits / Emballage

Legend Produktcodes / Verpackung

pag. 384

**LINES and WAVES**  
design  
Patrick Norguet



**LINE BLUE**  
100x300cm / 39"x118"



# LINES AND WAVES

design Patrick Norguet

 SLIMTECH

spessore / thickness **3,5mm**

**1**

**FORMATO** <sup>LT<sup>1</sup></sup>

size / format / Format

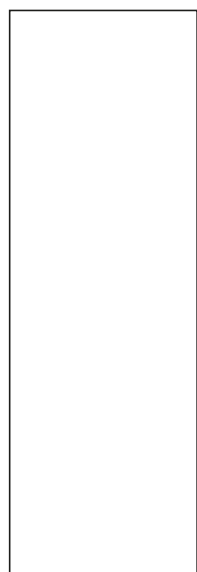

100x300cm / 39"x118"  
slimtech 3plus

LINES

**2**

**COLORI**

colors / couleurs / Farben

WAVES

**2**

**COLORI**

colors / couleurs / Farben

Line Blue

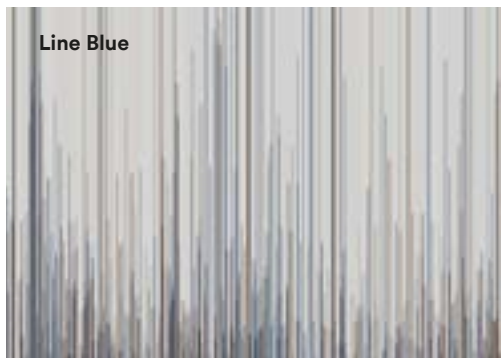

Line Grey



Wave Blue

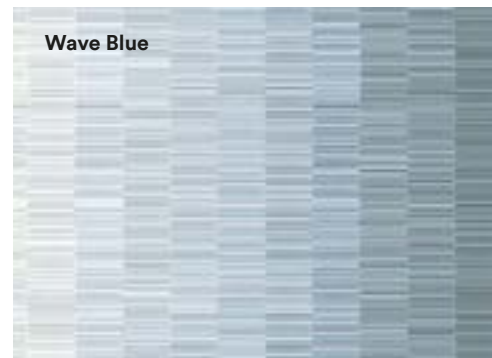

Wave Grey

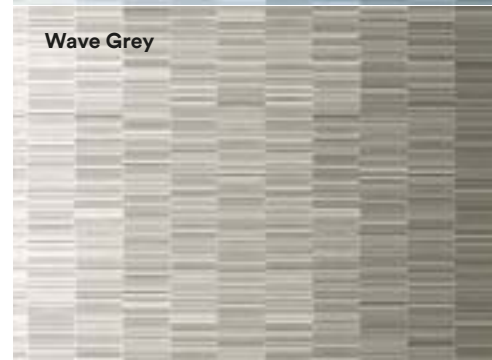





# LINES

156 / 157

**LINE GREY**  
100x300cm / 39"x118"







# LINES

design  
Patrick Norguet

LINE BLUE  
100x300cm / 39"x118"



LINE GREY  
100x300cm / 39"x118"



LINE BLUE  
100x300cm / 39"x118"







## WAVES

**WAVE BLUE**  
100x300cm / 39"x118"



**WAVE GREY**  
100x300cm / 39"x118"





# WAVES

design  
Patrick Norguet



WAVE BLUE A  
100x300cm / 39"x118"

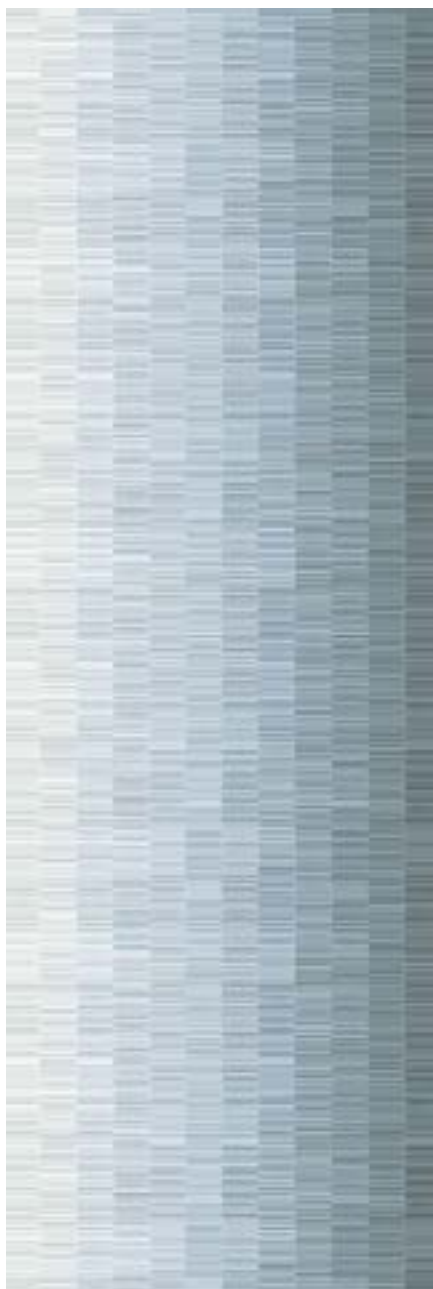

WAVE BLUE B  
100x300cm / 39"x118"



a	b	a	b
---	---	---	---

WAVE GREY A  
100x300cm / 39"x118"



WAVE GREY B  
100x300cm / 39"x118"



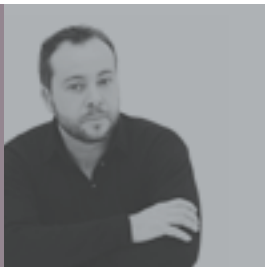

# WAVES

WAVE GREY

100x300cm / 39"x118"



## LINES AND WAVES

### GRES PORCELLANATO LAMINATO UGL

Laminated porcelain stoneware UGL / Grès laminé UGL / Laminiertes Feinsteinzeug UGL

### SPESSORE

Thickness / Epaisseur / Stärke

3,5 mm → slimtech 3plus



### STONALIZZAZIONE

Shading / Denuançage / Spielfarbig

ANSI A137.3

### FUGA MINIMA CONSIGLIATA

Minimum suggested joint

Joint minimum conseillé

Empfohlene Fugenbreite

**POSA A PARETE** / Wall / Mur / Wand

1 mm (INDOOR) → slimtech 5plus

### OUTDOOR

vedi Manuale Tecnico Slimtech

see Slimtech Technical Manual

### LEGENDA CODICI PRODOTTO / IMBALLI

Legend product codes / Packing

Légende codes produits / Emballage

Legend Produktcodes / Verpackung

pag. 384 Lines

pag. 390 Waves

**NEST**  
design Hok product design



ettagono  
L 50cm / 19<sup>1/2</sup>"

triangolo  
L 50cm / 19<sup>1/2</sup>"



# NEST

design Hok Product Design

 SLIMTECH

## 6

**FORMATI** 

sizes / formats / Formate

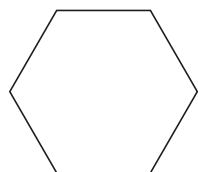

\*ESAGONO

L 50cm / 19<sup>1/2</sup>"

100x86,6cm / 39"x34<sup>1/8</sup>"



\*ESAGONO

L 25cm / 10"

50x43,2cm / 19<sup>1/2</sup>"x17"



\*ESAGONO

L 6,2cm / 2<sup>1/2</sup>"

12,5x10,8cm / 5"x4<sup>1/4</sup>"

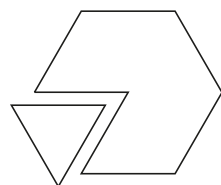

\*ETTAGONO

L 50cm / 19<sup>1/2</sup>"

100x86,6cm / 39"x34<sup>1/8</sup>"

\*TRIANGOLO

L 50cm / 19<sup>1/2</sup>"



\*ETTAGONO

L 25cm / 10"

50x43,2cm / 19<sup>1/2</sup>"x17"

\*TRIANGOLO

L 25cm / 10"



\*ETTAGONO

L 6,2cm / 2<sup>1/2</sup>"

12,5x10,8cm / 5"x4<sup>1/4</sup>"

\*TRIANGOLO

L 6,2cm / 2<sup>1/2</sup>"

### REALIZZABILE CON LE SERIE:

Can be made with the following collections: /

Réalisable avec les séries: /

Realisierbar mit den Serien:

ABSOLUTE

BASALTINA STONE PROJECT

GOUACHE.10

RE-EVOLUTION

SHADE

TAKE CARE

TIMELESS MARBLE

WATERFALL

# NEST



## NEST

### DECORO REALIZZATO CON GRES PORCELLANATO LAMINATO UGL

Decor made with laminated porcelain stoneware UGL / Décor réalisé avec grès laminé UGL  
Das Dekor ist aus hergestellt laminiertes Feinsteinzeug UGL

### SPESSORE

Thickness / Epaisseur / Stärke

3,5 mm → slimtech 3plus

5,5 mm → slimtech 5plus



### FUGA MINIMA CONSIGLIATA

Minimum suggested joint

Joint minimum conseillé

Empfohlene Fugenbreite

**POSA A PARETE** / Wall / Mur / Wand

1 mm (INDOOR) → slimtech 3plus - slimtech 5plus

**POSA A PAVIMENTO** / Floor / Sol / Boden

2 mm (INDOOR) → slimtech 3plus - slimtech 5plus

**Il decoro ottenuto da Slimtech Absolute, Basaltina Stone Project, Gouache.10, RE-evolution, Shade, Take Care, Timeless Marble, Waterfall è utilizzabile per pavimenti e rivestimenti.**

The decors made using Slimtech Absolute, Basaltina Stone Project, Gouache.10, RE-evolution, Shade, Take Care, Timeless Marble, Waterfall can be used for both floor and wall applications.

Les décors produit en utilisant Slimtech Absolute, Basaltina Stone Project, Gouache.10, RE-evolution, Shade, Take Care, Timeless Marble, Waterfall sont utilisables au mur ainsi qu'au sol.

Dekor aus den Kollektionen Slimtech Absolute, Basaltina Stone Project, Gouache.10, RE-evolution, Shade, Take Care, Timeless Marble, Waterfall ist für Wand und Boden geeignet.

**I decori NEST sono venduti esclusivamente a scatola intera. All'interno delle scatole sono presenti pezzi dello stesso colore.**

The NEST decors are sold only in full boxes. In each box there is only one color.

Les décors NEST sont vendus uniquement par boîte entière. Dans les boîtes sont présents des articles de la même couleur.

Die Dekore NEST werden ausschließlich in kompletten Kartoneinheiten verkauft. Die Kartons enthalten jeweils eine Farbe.

### LEGENDA CODICI PRODOTTO / IMBALLI

Legend product codes / Packing

Légende codes produits / Emballage

Legend Produktcodes / Verpackung

pag. 385



ettagono  
L 25cm / 10"  
50x43,5cm / 19<sup>1</sup>/<sub>2</sub>" x 17"

triangolo  
L 25cm / 10"

**MAUK**  
design  
Diego Grandi



**LAPPATA**

spina  
8,7x13,5x25,8cm / 3<sup>3/8</sup>" x 5<sup>3/8</sup>" x 10<sup>1/8</sup>"

cuadra  
57,6cm / 22<sup>5/8</sup>"

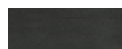

**NATURALE**

cuadra  
57,6cm / 22<sup>5/8</sup>"



**SABBIATA**

cuadra  
57,6cm / 22<sup>5/8</sup>"

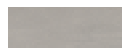

# MAUK

design Diego Grandi

**S** LIMTECH

spessore / thickness **3,5mm**

## 3

**FORMATI**  $\text{LRT}^{\text{T}}$

sizes / formats / Formate

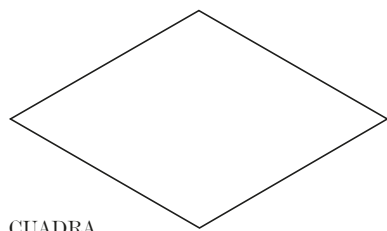

**CUADRA**  
57,6cm / 22<sup>5/8</sup>"  
slimtech 3plus

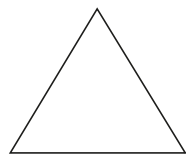

**ESA**  
38,3cm / 15<sup>1/8</sup>"  
slimtech 3plus



**SPINA**  
base maggiore 25,8cm/10<sup>1/8</sup>"  
base minore 13,5cm/5<sup>3/8</sup>"  
lati 8,7cm/3<sup>3/8</sup>"  
slimtech 3mm

## 3

**COLORI**

colors / couleurs / Farben

Sabbiata

Naturale

Lappata

shapes & colors





# MAUK

172/  
173

**SABBIATA**  
cuadra  
57,6cm / 22<sup>5/8</sup>"

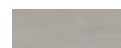

**NATURALE**  
cuadra  
57,6cm / 22<sup>5/8</sup>"



**LAPPATA**  
cuadra  
57,6cm / 22<sup>5/8</sup>"

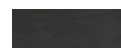





## SABBIATA

## LAPPATA

spina

8,7x13,5x25,8cm / 3<sup>3/8</sup>"x5<sup>3/8</sup>"x10<sup>1/8</sup>"

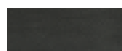

## MAUK

### GRES PORCELLANATO LAMINATO UGL

Laminated porcelain stoneware UGL / Grès laminé UGL / Laminiertes Feinsteinzeug UGL

### SPESSORE

Thickness / Epaisseur / Stärke

3,5 mm → slimtech 3plus (cuadra - esa)



### FUGA MINIMA CONSIGLIATA

Minimum suggested joint

Joint minimum conseillé

Empfohlene Fugenbreite

**POSA A PARETE** / Wall / Mur / Wand

1 mm (INDOOR) → slimtech 5plus

**POSA A PAVIMENTO** / Floor / Sol / Boden

2 mm (INDOOR) → slimtech 5plus

### OUTDOOR

vedi Manuale Tecnico Slimtech

see Slimtech Technical Manual



V3

### STONALIZZAZIONE

Shading / Denuançage / Spielfarbig

**ANSI A137.3**

### LEGENDA CODICI PRODOTTO / IMBALLI

Legend product codes / Packing

Légende codes produits / Emballage

Legend Produktcodes / Verpackung

pag. 385



 SLIMTECH

LEALAB

176/  
177

Con LeaLab il gres laminato Slimtech diventa materiale mutante in grado di rispondere ad esigenze progettuali inaspettate e sorprendenti. La competenza tecnica di Lea Ceramiche e la sua naturale attitudine a produrre prodotti di qualità, costituiscono assoluta garanzia per supportare, in ogni sua fase, qualsiasi progetto in architettura, come nel residenziale. LeaLab rappresenta l'avanguardia nella personalizzazione del prodotto ceramico. Per ogni informazione: [www.leaceramiche.com](http://www.leaceramiche.com).

With Lealab, Slimtech laminated porcelain stoneware becomes a material that transforms to suit the needs of the most unexpected and surprising project requirements. Lea Ceramiche's technical skills and its natural penchant for producing high quality products are an absolute guarantee of its ability to support, at every stage, any architectural or residential project. LeaLab is at the forefront in the personalization of ceramic products. For more informations please visit [www.leaceramiche.com](http://www.leaceramiche.com).





Avec LeaLab, le grès laminé Slimtech devient un matériau changeant en mesure de répondre à des exigences de projet inattendues et étonnantes. La compétence technique de Lea Ceramiche et sa propension naturelle à fabriquer des produits de qualité constituent une garantie absolue pour assumer n'importe quelle phase d'un projet, aussi bien en architecture que dans le domaine résidentiel. LeaLab représente l'avant-garde de la personnalisation du produit en céramique. Pour toute information : [www.leaceramiche.com](http://www.leaceramiche.com).

Mit LeaLab wird das laminierte Feinsteinzeug Slimtech zu einem mutierenden Material, in der Lage den unerwarteten und überraschenden Designanforderungen entgegen zu kommen. Die technische Kompetenz von Lea Ceramiche und ihre natürliche Fähigkeit, qualitativ hochwertige Produkte herzustellen, bilden eine absolute Garantie, um jedes architektonische Projekt in jeder hase, wie im Wohnbereich, zu unterstützen. LeaLab steht für den Fortschritt bei der Personalisierung von keramischen Produkten. Für weitere Informationen: [www.leaceramiche.com](http://www.leaceramiche.com).

# DESTINAZIONI D'USO

intended uses  
destinations d'usage  
anwendungen

	<b>POSA A PAVIMENTO FLOOR INSTALLATION POSE AU SOL FUSSBODENVERLEGUNG</b>			<b>POSA A PARETE WALL INSTALLATION POSE AU MUR WANDVERLEGUNG</b>			
	<b>IN INTERNO</b>			<b>IN ESTERNO</b>			
<p>Prodotti con finiture particolari possono prevedere limitazioni nelle destinazioni d'uso. Verificare nei singoli cataloghi di collezione.</p> <p>Products with special finishes can have limitations depending on their area of application. Refer to specific collection catalogues.</p> <p>Les produits avec des finitions particulières peuvent prévoir des limites d'application. Contrôler dans chaque catalogue de la collection.</p> <p>Für Produkte mit besonderem Finish können endungseinschränkungen gelten. Bitte in den einzelnen Katalogen der Kollektionen nachprüfen.</p>	<p>Situazioni applicative sia per interventi di NUOVA COSTRUZIONE che di RISTRUTTURAZIONI con posa in sovrapposizione a pavimenti preesistenti.</p>	<p><b>RESIDENZIALE</b> (cucine, bagni, living, aree comuni condominiali ed ogni altro ambiente di uso residenziale). <b>slimtech 3plus</b> <b>slimtech 5plus</b></p>	<p><b>COMMERCIALE LEGGERO</b> (uffici, uffici aperti al pubblico, sale d'attesa, negozi, bagni, sale di ristoranti, autosaloni, bar, cinema, ambulatori/cliniche). <b>slimtech 3plus</b> <b>slimtech 5plus</b></p>	<p><b>COMMERCIALE INTENSIVO</b> (aree comuni di centri commerciali, hall di alberghi, mense, fast food, discoteche, ospedali) ad esclusione di zone sottoposte al passaggio di carichi pesanti concentrati (ad es. carrelli a ruote dure). <b>slimtech 5plus</b></p>	<p>A condizione che le superfici siano coperte (es. loggie, balconi coperti, ecc.) e perfettamente impermeabilizzate. Si consiglia l'utilizzo di formati non superiori a 50x50 cm. <b>slimtech 3plus</b> <b>slimtech 5plus</b></p>	<p>Situazioni applicative sia per interventi di NUOVA COSTRUZIONE che di RISTRUTTURAZIONI con posa in sovrapposizione a rivestimenti preesistenti.</p>	<p>Qualunque ambiente residenziale e commerciale, in situazioni dove <b>non</b> si devono praticare fori e/o tagli interni. <b>slimtech 3plus</b> <b>slimtech 5plus</b></p>
	<p>For NEW BUILDINGS and REFURBISHING, for installation on pre-existing floors.</p>	<p><b>RESIDENTIAL</b> (kitchens, bathrooms, living rooms, common apartment block areas and any other residential environment). <b>slimtech 3plus</b> <b>slimtech 5plus</b></p>	<p><b>LIGHT COMMERCIAL</b> (offices, offices open to the general public, waiting rooms, shops, bathrooms, restaurant dining rooms, car showrooms, bars, cinemas, surgeries/clinics). <b>slimtech 3plus</b> <b>slimtech 5plus</b></p>	<p><b>INTENSIVE COMMERCIAL</b> (common areas of shopping centres, hotel halls, canteens, fast food restaurants, dance clubs, hospitals) with the exception of areas subject to heavy concentrated loads (e.g. trolleys with hard wheels). <b>slimtech 5plus</b></p>	<p>Upon condition that surfaces are sheltered (e.g. loggias, covered balconies, etc.) and made totally impervious. The use of sizes that are not larger than 50x50cm is recommended. <b>slimtech 3plus</b> <b>slimtech 5plus</b></p>	<p>For NEW BUILDINGS and REFURBISHING, for installation on pre-existing walls.</p>	<p>Any residential and commercial environment, in situations where holes and/or cuts are <b>not</b> necessary. <b>slimtech 3plus</b> <b>slimtech 5plus</b></p>
	<p>Application dans des NOUVELLES CONSTRUCTIONS ou des RESTRUCTURATIONS, avec pose sur des sols préexistants.</p>	<p><b>RÉSIDENTIEL</b> (cuisines, salles de bains, salles de séjour, zones de copropriété collectives et tout autre espace à usage résidentiel). <b>slimtech 3plus</b> <b>slimtech 5plus</b></p>	<p><b>COMMERCIAL LÉGER</b> (bureaux, bureaux ouverts au public, salles d'attente, magasins, salles de bains, salles de restaurants, salons automobiles, bars, cinémas, dispensaires/cliniques). <b>slimtech 3plus</b> <b>slimtech 5plus</b></p>	<p><b>COMMERCIAL INTENSIF</b> (zones communes de centres commerciaux, halls d'hôtels, cantines, fast-foods, discothèques, hôpitaux, sauf les zones soumises au passage de charges lourdes concentrées (ex. : chariots à roues dures). <b>slimtech 5plus</b></p>	<p>À condition que les surfaces soient couvertes (loggias, balcons couverts, etc.) et parfaitement imperméabilisées. Il est conseillé d'utiliser des formats non supérieurs à 50x50 cm. <b>slimtech 3plus</b> <b>slimtech 5plus</b></p>	<p>Application dans des NOUVELLES CONSTRUCTIONS ou des RESTRUCTURATIONS, avec pose sur des supports préexistants.</p>	<p>Tout espace résidentiel et commercial, dans des endroits où <b>il n'est pas</b> nécessaire d'effectuer des trous et/ou des découpes internes. <b>slimtech 3plus</b> <b>slimtech 5plus</b></p>
	<p>Anwendungslösungen sowohl für NEUBAUTEN als auch für RENOVIERUNGEN mit Verlegung auf vorhandenen Bodenbelägen.</p>	<p><b>WOHNBEREICHE</b> (Küchen, Badezimmer, Wohnzimmer, Gemeinschaftsflächen in Mehrfamilienhäusern und alle sonstigen Wohnbereiche). <b>slimtech 3plus</b> <b>slimtech 5plus</b></p>	<p><b>LEICHTE GEWERBLICHE ANWENDUNGEN</b> (Büros, Wartezimmer, Geschäfte, Toiletten, Gaststätten, Autohäuser, Cafés, Kinos, Praxen/Kliniken). <b>slimtech 3plus</b> <b>slimtech 5plus</b></p>	<p><b>INTENSIVE GEWERBLICHE ANWENDUNGEN</b> (gemeinschaftsbereiche in einkaufszentren, hotelhallen, kantinen, fastfood-restaurants, diskotheken, krankenhäuser), mit ausnahme von bereichen mit schwerlastverkehr (z.b. stapler mit hartgummirädern). <b>slimtech 5plus</b></p>	<p>Die Verlegung in Außenbereichen ist möglich, wenn die Oberflächen überdacht und vollkommen abgedichtet sind (überdachte Balkons, Veranden, usw.). Es sollten keine größeren Formate als 50x50 cm verwendet werden. <b>slimtech 3plus</b> <b>slimtech 5plus</b></p>	<p>Anwendungslösungen sowohl für NEUBAUTEN als auch für RENOVIERUNGEN mit Verlegung auf vorhandenen Wandverkleidungen.</p>	<p>Alle Wohn- und Gewerbebereiche, in Situationen, die keine Bohrungen und/oder Innenschnitte verlangen. <b>slimtech 3plus</b> <b>slimtech 5plus</b></p>

			DESTINAZIONI SPECIALI SPECIAL USES UTILISATIONS SPÉCIALES SPEZIELLE VERWENDUNGSZWECKE				
							
	IN ESTERNO			FACCIAE VENTILATE	RIVESTIMENTI TERMICI A CAPPOTTO	RIVESTIMENTI VASCHE E PISCINE	SUPERFICI DA RIVESTIRE NEL SETTORE DELL'ARREDAMENTO
Qualunque ambiente residenziale e commerciale, in situazioni dove si devono praticare fori e/o tagli interni.	In situazioni dove <b>non</b> si devono praticare fori e/o tagli interni e con formati fino a 100x100 cm. <b>slimtech 3plus</b> <b>slimtech 5plus</b>	In situazioni dove si devono praticare fori e/o tagli interni e/o per formati grandi. <b>slimtech 3plus</b> <b>slimtech 5plus</b>	In funzione delle specifiche del progetto, in abbinamento a sistemi costruttivi indicati da Panariagroup e approvati dalla Direzione Lavori.	<b>slimtech 3plus</b> <b>slimtech 5plus</b>	<b>slimtech 3plus</b> <b>slimtech 5plus</b>	<b>slimtech 3plus</b> <b>slimtech 5plus</b>	<b>slimtech 3plus</b> <b>slimtech 5plus</b>
	EXTERIORS			VENTILATED FACADES	THERMAL INSULATION SYSTEMS	POOL AND SWIMMING POOL TILING	FOR FURNITURE SURFACES
Any residential and commercial environment, in situations where holes and/or cuts are necessary.	In situations where holes and/or cuts are <b>not</b> necessary and with sizes up to 100 x 100 cm. <b>slimtech 3plus</b> <b>slimtech 5plus</b>	In situations where holes and/or cuts are necessary and/or for large sizes. <b>slimtech 3plus</b> <b>slimtech 5plus</b>	Depending on project specifications and in combination with the construction systems recommended by Panariagroup and approved by the Installation Supervisor.	<b>slimtech 3plus</b> <b>slimtech 5plus</b>	<b>slimtech 3plus</b> <b>slimtech 5plus</b>	<b>slimtech 3plus</b> <b>slimtech 5plus</b>	<b>slimtech 3plus</b> <b>slimtech 5plus</b>
	EN EXTÉRIEUR			FAÇADES VENTILÉES	REVÊTEMENTS THERMIQUES À MUR-MANTEAU	REVÊTEMENTS BAIGNOIRES ET PISCINES	SURFACES À REVÊTIR DANS LE SECTEUR DE LA DÉCORATION
Tout espace résidentiel et commercial, dans des endroits où il est nécessaire d'effectuer des trous et/ou des découpes internes.	Dans les situations où <b>il ne faut pas</b> percer de trous ni pratiquer de découpes internes et avec des formats jusqu'à 100x100 cm. <b>slimtech 3plus</b> <b>slimtech 5plus</b>	Dans les situations où il faut percer des trous ou pratiquer des découpes internes ou pour de grands formats. <b>slimtech 3plus</b> <b>slimtech 5plus</b>	En fonction des caractéristiques du projet et en combinaison avec les systèmes de construction indiqués par Panariagroup et approuvés par les maîtres d'oeuvre.	<b>slimtech 3plus</b> <b>slimtech 5plus</b>	<b>slimtech 3plus</b> <b>slimtech 5plus</b>	<b>slimtech 3plus</b> <b>slimtech 5plus</b>	<b>slimtech 3plus</b> <b>slimtech 5plus</b>
	AUSSENBEREICH			HINTERLÜFTETE FASSADEN	WÄRMEDÄMMVERBUND-SYSTEME	VERKLEIDUNG VON BECKEN UND SCHWIMMBECKEN	FLÄCHEN, DIE IM RAHMEN DER INNENEINRICHTUNG VERKLEIDET WERDEN
Alle Wohn- und Gewerbebereiche, in Situationen, die Bohrungen und/oder Innenschnitte verlangen.	In Situationen, in denen keine internen Bohrungen und/oder Schnitte gefertigt werden müssen und mit Formaten bis 100x100 cm. <b>slimtech 3plus</b> <b>slimtech 5plus</b>	In Situationen, in denen interne Bohrungen und/oder Schnitte gefertigt werden müssen und/oder für Großformate. <b>slimtech 3plus</b> <b>slimtech 5plus</b>	In Funktion der Projektangaben und in Kombination mit Konstruktionssystemen, die Panariagroup vorgibt und die Arbeitsleitung genehmigt.	<b>slimtech 3plus</b> <b>slimtech 5plus</b>	<b>slimtech 3plus</b> <b>slimtech 5plus</b>	<b>slimtech 3plus</b> <b>slimtech 5plus</b>	<b>slimtech 3plus</b> <b>slimtech 5plus</b>

Sperimentazione, design, ricerca, tecnologia, qualità: questi i valori fondamentali di Lea Ceramiche. La ricerca di soluzioni d'avanguardia è una componente strategica della produzione di Lea Ceramiche e rappresenta da sempre un valore distintivo dell'azienda. Le collezioni Lea Ceramiche sono particolarmente riconoscibili per la spiccata impronta stilistica e l'elevato contenuto tecnologico e di ricerca.

Experimentation, design, research, technology, quality: these are Lea Ceramiche's fundamental values. The search for cutting edge solutions is a strategic component of Lea Ceramiche's manufacturing and has always been one of the values that sets the company apart. Lea Ceramiche's collections are particularly recognizable for their unique style and their high level of technology and research.

Expérimentation, design, recherche, technologie et qualité sont les valeurs fondamentales de Lea Ceramiche. La recherche de solutions à l'avant-garde, qui permet depuis toujours à la société de se différencier des autres, est une étape stratégique de la production chez Lea Ceramiche. Les collections Lea Ceramiche possèdent cette touche de style unique et canalisent dans chaque produit une haute concentration de technologie et de recherche, se distinguant ainsi de toutes autres gammes.

Forschung, Design, Technologie und Qualität: das sind die Grundwerte von Lea Ceramiche. Die Suche nach fortschrittlichen Lösungen ist eine strategische Komponente der Produktion von Lea Ceramiche und zeichnet seit jeher das Unternehmen aus. Lea Ceramiche Kollektionen sind besonders erkennbar dank ihrer unverwechselbaren stilistischen Prägung und dem hohen Gehalt an High-Tech und Forschung.















# GRES AND MORE

- 184 contemporary  
**TRAME**
- 196  
**DISTRICT**
- 210  
**METROPOLIS**
- 220  
**MAKÒ**
- 226  
**STONECLAY / HOME**
- 232 stone  
**NEXTONE**
- 248  
**WATERFALL**
- 260  
**CLIFFSTONE**
- 272  
**BASALTINA STONE PROJECT**
- 280  
**TECNOQUARTZ**
- 288 marble  
**DREAMING**
- 302 wood  
**BIO RECOVER**
- 310  
**BIO LUMBER**
- 318  
**BIO TIMBER**
- 326  
**BIO PLANK**
- 330 shapes & colors  
**CITY**
- 334  
**GOCCIA / MONOPOROSA**
- 
- 342  
**LINK / PERCORSI TATTILI**
- 346  
**SYSTEM L2 / 20MM**

## GRES PORCELLANATO Full-body porcelain / Grès Cérame pleine masse / Vollgemischtes Durchgefärbtes Feinsteinzeug

### FORMATI (CM)

Sizes - Formats - Formate

															
	20x180	60x120	30x120	20x120	90x90	60x90	45x90	30x90	75x75	60x60	40x60	30x60	20x60	30x30	20x30
<b>Basaltina Stone P.</b>		●								●		●			
<b>Bio Lumber</b>			⊕ ●	●											
<b>Bio Plank</b>				●											
<b>Bio Recover</b>	●			▲											
<b>Bio Timber</b>				●											
<b>City</b>												●			
<b>Cliffstone</b>		●			●	●				⊕ ●	●	●	●		
<b>District</b>					●		●			●		●			
<b>Dreaming</b>		●							●	●		●			
<b>Makò</b>										●		●			
<b>Metropolis</b>					●		●			●		●			
<b>Nextone</b>		⊕ ●								⊕ ●		●			
<b>Stoneclay home</b>										⊕ ● ▲		●			
<b>Tecnoquartz</b>										●	●	●	●	●	●
<b>Trame</b>					●			●							
<b>Waterfall</b>		●			●		⊕ ●			⊕ ●		●			

● BORDO RETTIFICATO



▲ BORDO NATURALE

⊕ SYSTEM L2 20mm

## MONOPOROSA White body tiles / Monocuisson / Glasierten Monoporosa

### FORMATI (CM)













Sizes - Formats - Formate

		
	10x40	13x13
<b>Goccia</b>	▲	▲



## PEZZI SPECIALI (CM)











Trims / Pièces spéciales / Formstücke

											
		•		•	•	•		•		•	•
		•		•	•						
		•		•	•						
		•		•	•						
		•		•	•						
		•		•	•	•		•			
		•				•		•			
		•				•		•		•	•
		•							•	•	•
	•			•	•	•		•			
		•							•		
			•			•		•		•	•
•							•	•			
		•		•	•	•		•			

## FORMATI SPECIALI

special sizes / formats spéciaux / Sonderformate

## (rett) BORDO RETTIFICATO - Edge Rectified - Bord Rectifié - Fliesenrand Rektifiziertes

										
	GRAMMA 72 49,8x14,5	GRAMMA 66 16,9x39,2	GRAMMA 16 19,5x8,3	GRAMMA 38 9,7x39,2	ESA 9,7x33,8	LISTELLO 5x45	CUADRA 11,2x9,7	LISTELLO 9,7x60	LISTELLO 2x60	TOZZETTO 2x2
<b>Makò</b>								•	•	•
<b>Nextone</b>	•									
<b>Trame</b>		•		•	•	•	•			
<b>Waterfall</b>	•	•	•							

contemporary



**CANVAS TORTORA**  
90x90cm / 36"x36"  
**ROLLER**



**CANVAS MORO**  
gramma 66 dx e sx - esa  
**ROLLER**



**PLASTER ARGILLA**  
gramma 66 sx



**MATTER LINO**  
gramma 66 dx



**CANVAS MORO**  
esa



# TRAME

 gres porcellanato

**PROTECT**  
ANTIBATTERICO - ANTIMICROBIAL

spessore / thickness 11mm

## 7

### FORMATI

sizes / formats / Formate

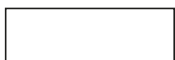

30x90 cm / 12"x36" rett

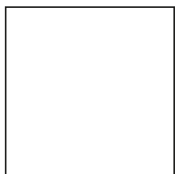

90x90cm / 36"x36" rett

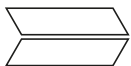

gramma 38  
9,7x39,2 cm / 3<sup>3/4</sup>"x15<sup>3/8</sup>" rett

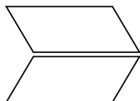

gramma 66 dx e sx  
16,9x39,2 cm / 6<sup>5/8</sup>"x15<sup>3/8</sup>" rett



cuadra  
11,2x9,7 cm / 4<sup>3/8</sup>"x3<sup>3/4</sup>" rett



esa  
9,7x33,8 cm / 3<sup>13/16</sup>"x13<sup>3/8</sup>" rett



listello  
5x45 cm / 2"x18" rett

## 3

### FINITURE

finishes / surfaces / Oberfläche

**PLASTER**

**MATTER**

**CANVAS**

## 6

### COLORI

colors / couleurs / Farben

Plaster Lino	Matter Lino	Canvas Lino			
Plaster Corda	Matter Corda	Canvas Corda			
Plaster Tortora	Matter Tortora	Canvas Tortora	Plaster Tabacco	Matter Tabacco	Canvas Tabacco
Plaster Moro	Matter Moro	Canvas Moro	Plaster Argilla	Matter Argilla	Canvas Argilla

# TRAME

**MATTER CORDA**  
90x90cm / 36"x36"

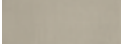

**CANVAS TORTORA**  
90x90cm / 36"x36"

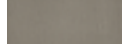



**PLASTER LINO**  
90x90cm / 36"x36"



contemporary



## TRAME

### CHEVRON

---

#### MATTER MORO

gramma 38



#### MATTER ARGILLA

gramma 38



#### ARGILLA

cube



#### PLASTER ARGILLA

90x90cm / 36"x36"





**CANVAS MORO**  
90x90cm / 36"x36"



contemporary





# TRAME

**MATTER ARGILLA**  
90x90cm / 36"x36"



190/  
191



**ROLLER**

**CANVAS MORO**  
gramma 66 dx e sx  
esa



## TRAME

## PEZZI SPECIALI

trims / pièces spéciales  
Formstücke

**BATTISCOPIA**  
8x90 cm / 3<sup>1/8</sup>"x36" rett

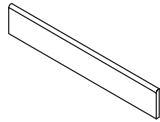

**GRADINO PLUS\***  
35x45 cm / 13<sup>3/4</sup>"x18" rett

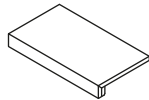

**ANGOLO GRADINO PLUS\***  
35x35 cm / 13<sup>3/4</sup>"x13<sup>3/4</sup>" rett  
Plaster e Canvas

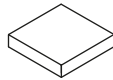

**ANGOLO SX GRADINO PLUS\***  
35x35 cm / 13<sup>3/4</sup>"x13<sup>3/4</sup>" rett  
Matter

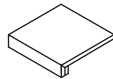

**ANGOLO DX GRADINO PLUS\***  
35x35 cm / 13<sup>3/4</sup>"x13<sup>3/4</sup>" rett  
Matter

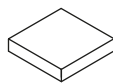

## MOSAICI

mosaics / mosaïques / Mosaik

**ARROW**  
11,2x39,5 cm / 4<sup>13/32</sup>"x13<sup>35/64</sup>"

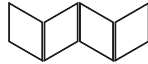

**CUBE**  
39,5x34,1 cm / 13<sup>35/64</sup>"x11<sup>27/64</sup>"

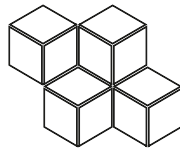

**LEAF**  
39,5x34,1 cm / 13<sup>35/64</sup>"x11<sup>27/64</sup>"

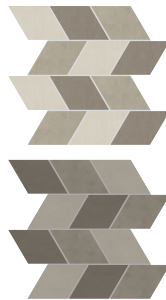

**JEWEL**  
33,7x29,7 cm / 11<sup>17/64</sup>"x11<sup>11/16</sup>"

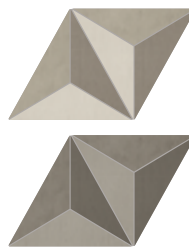

## FORMATI SPECIALI

special sizes / formats spéciaux  
Sonderformate

**ESA**  
9,7x33,8 cm / 3<sup>13/16</sup>"x13<sup>3/8</sup>"



**GRAMMA 66 SX**  
16,9x39,2 cm / 6<sup>5/8</sup>"x15<sup>3/8</sup>"



**GRAMMA 66 DX**  
16,9x39,2 cm / 6<sup>5/8</sup>"x15<sup>3/8</sup>"



**CUADRA**  
11,2x9,7 cm / 4<sup>3/8</sup>"x3<sup>3/4</sup>"



**GRAMMA 38**  
9,7x39,2 cm / 3<sup>3/4</sup>"x15<sup>3/8</sup>"

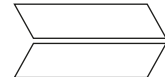

**LISTELLO**  
5x45 cm / 2"x18"

**ARROW**

**disponibile su tutti i colori / superfici (18 elementi)**

available in all colors / surfaces (18 items) /  
disponible sur toutes les couleurs / surfaces (18 éléments) /  
Erhältlich für alle Farben / Oberflächen (18 Elemente)

**CUBE**

**disponibile su tutti i colori multisuperficie (6 elementi)**

available in all multi-surface colors (6 items) /  
disponible sur toutes les couleurs multi-surface (6 éléments) /  
Erhältlich für alle Farben und verschiedene Oberflächen  
(6 Elemente)

Es: Cube Corda = Plaster corda + Canvas Corda + Matter Corda

**LEAF / JEWEL**

**versione chiara e versione scura multisuperficie (2 elementi)**

multi-surface light and dark versions (2 items) /  
version claire et version foncée multi-surface (2 éléments) /  
Helle und dunkle Version verschiedener Oberflächen  
(2 Elemente)

Chiaro: CANVAS LINO + MATTER TABACCO + PLASTER CORDA  
Scuro: CANVAS ARGILLA + MATTER MORO + PLASTER TORTORA

\* **Su richiesta.** / Upon request. /  
Sur demande. / auf Anfrage.

**COMPOSIZIONI A MODULI SU RETE**

mesh-mounted tile layouts / compositions en modules sur filet / Modul-Kompositionen auf Netz

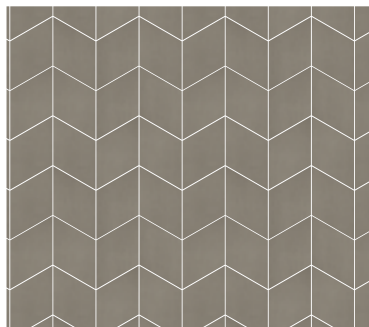
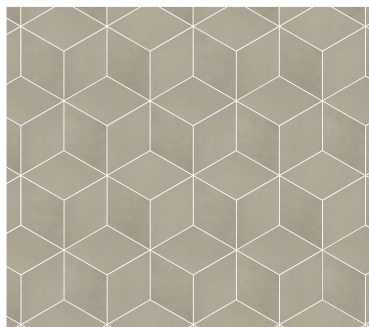
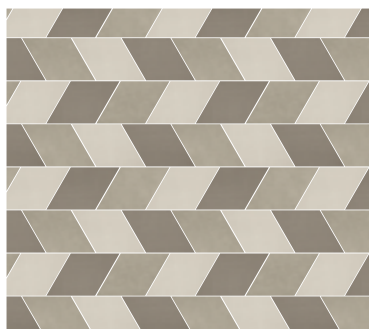
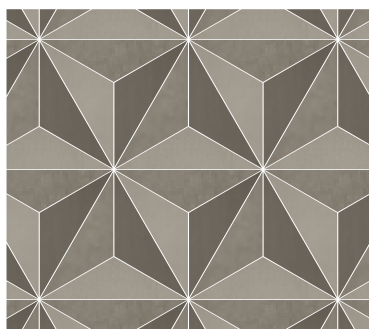
**ARROW****CUBE****LEAF****JEWEL****COMPOSIZIONI A MODULI SFUSI**

tile layouts in loose modules / compositions en modules en vrac / Kompositionen mit Einzelmodulen

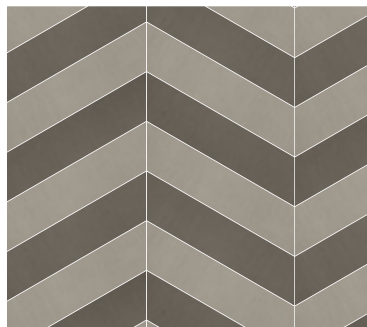
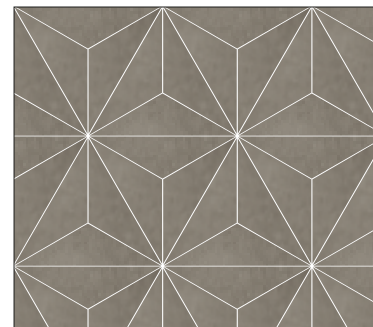
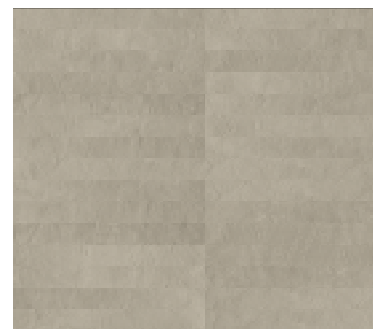
**CHEVRON** (GRAMMA 38 100%)**ROLLER** (GRAMMA 66 DX 40% - SX 40% + ESA 20%)**BOLT** (LISTELLO)**WALL** (LISTELLO)**TWIST** (GRAMMA 66 SX 100%)**JEWEL** (ESA 100%)**GRID** (LISTELLO)

contemporary

# TRAME



## TRAME

### GRES TUTTA MASSA UGL

Full-body porcelain / Grès Cérame pleine masse  
Vollgemischtes Durchgefärbtes Feinsteinzeug

### SPESSORE

Thickness / Epaisseur / Stärke

11 mm

### FUGA MINIMA CONSIGLIATA

Minimum suggested joint

Joint minimum conseillé

Empfohlene Fugenbreite

#### RECT

2 mm (INDOOR)

#### NON RECT

3-4 mm Approx (INDOOR)

#### OUTDOOR

5-6 mm Approx (\*)

(\*) Decisione a cura della Direzione Lavori Codici di Posa Nazionali

Decision by the Construction Manager / National Laying Standards

Décision établie par la Direction des Travaux/Codes de Pose Nationaux

Die Entscheidung wird von der Bauleitung/gemäß nationalen Vorschriften getroffen.



### STONALIZZAZIONE

Shading / Denuançage / Spielfarbig

ANSI A137.1

### RESISTENZA ALLO SCIVOLAMENTO

Slip resistance / Résistance au glissement

Rutschfestigkeit

#### DIN 51130

R9 (plaster) / R10 (matter / canvas)

#### DIN 51097

B (A+B) (matter)

#### B.C.R. - TORTUS

$\mu > 0,40$

#### ANSI A326.3

DCOF  $\geq 0.42$

### LEGENDA CODICI PRODOTTO / IMBALLI

Legend product codes / Packing

Légende codes produits / Emballage

Legend Produktcodes / Verpackung

pag. 414/415

### P R ( ) T E C T

ANTIBATTERICO - ANTIMICROBIAL

### JEWEL SCURO



### MATTER LINO

90x90cm / 36" x 36"



contemporary



**BOULEVARD**

60x60cm / 24"x24"  
nat

30x60cm / 12"x24"  
nat



# DISTRICT

 gres porcellanato

**PROTECT**  
ANTIBATTERICO - ANTIMICROBIAL

spessore / thickness **10mm / 11mm**

**4**

**FORMATI** 

sizes / formats / Formate



30x60cm / 12"x24" rett  
nat

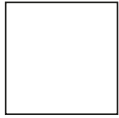

60x60cm / 24"x24" rett  
nat / grip



45x90cm / 18"x36" rett  
nat

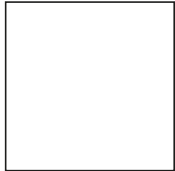

90x90cm / 36"x36" rett  
nat

**2**

**FINITURE**

finishes / surfaces / Oberfläche

**NAT**

**GRIP**

**4**

**COLORI**

colors / couleurs / Farben

**Street**

**Avenue**

**Boulevard**

**Route**







## DISTRICT

198/  
199

**ROUTE**  
45x90cm / 18"x36"  
nat



contemporary



## DISTRICT



**BOULEVARD**  
metropolitan  
60x60cm / 24"x24"





**AVENUE**  
60x60cm / 24"x24"  
nat  
—  
60x60cm / 24"x24"  
grip



contemporary



# DISTRICT

## STREET

90x90cm / 36"x36"  
nat



## AVENUE

60x60cm / 24"x24"  
grip







## DISTRICT

204/  
205

**ROUTE**  
queens mix  
30x30cm / 12"x12"



# DISTRICT

## DECORI

decors / articles / Dekore

METROPOLITAN  
street  
60x60cm / 24"x24"



GUGGENHEIM  
street  
60x60cm / 24"x24"



MOMA  
street  
60x60cm / 24"x24"



METROPOLITAN  
avenue  
60x60cm / 24"x24"



GUGGENHEIM  
avenue  
60x60cm / 24"x24"



MOMA  
avenue  
60x60cm / 24"x24"



CENTRAL PARK  
street  
30x30cm / 12"x12"



BRYANT PARK  
street  
30x30cm / 12"x12"

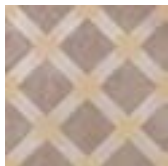

QUEENS MIX  
street  
30x30cm / 12"x12"

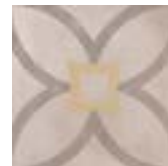
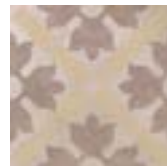

CENTRAL PARK  
avenue  
30x30cm / 12"x12"

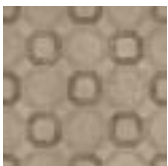

BRYANT PARK  
avenue  
30x30cm / 12"x12"

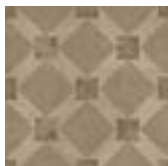

QUEENS MIX  
avenue  
30x30cm / 12"x12"

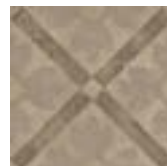



METROPOLITAN  
boulevard  
60x60cm / 24"x24"



GUGGENHEIM  
boulevard  
60x60cm / 24"x24"



MOMA  
boulevard  
60x60cm / 24"x24"



METROPOLITAN  
route  
60x60cm / 24"x24"



GUGGENHEIM  
route  
60x60cm / 24"x24"



MOMA  
route  
60x60cm / 24"x24"



CENTRAL PARK  
boulevard  
30x30cm / 12"x12"



BRYANT PARK  
boulevard  
30x30cm / 12"x12"



QUEENS MIX  
boulevard  
30x30cm / 12"x12"



CENTRAL PARK  
route  
30x30cm / 12"x12"



BRYANT PARK  
route  
30x30cm / 12"x12"

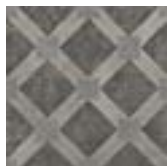

QUEENS MIX  
route  
30x30cm / 12"x12"

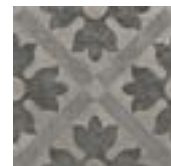
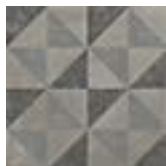

# DISTRICT

## MOSAICI

mosaics / mosaïques / Mosaik

MURETTO  
street  
30x60cm / 12"x24"



MOSAICO 81  
street  
30x30cm / 12"x12"



MOSAICO MATTONE  
street  
30x30cm / 12"x12"

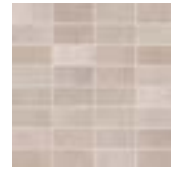

MURETTO  
avenue  
30x60cm / 12"x24"



MOSAICO 81  
avenue  
30x30cm / 12"x12"

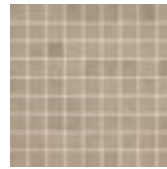

MOSAICO MATTONE  
avenue  
30x30cm / 12"x12"



MURETTO  
boulevard  
30x60cm / 12"x24"



MOSAICO 81  
boulevard  
30x30cm / 12"x12"

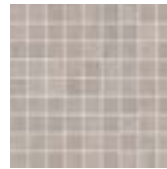

MOSAICO MATTONE  
boulevard  
30x30cm / 12"x12"



MURETTO  
route  
30x60cm / 12"x24"



MOSAICO 81  
route  
30x30cm / 12"x12"



MOSAICO MATTONE  
route  
30x30cm / 12"x12"



**PEZZI SPECIALI**

trims / pièces spéciales  
Formstücke

**BATTISCOPA**  
10x60cm / 4"x24" rett

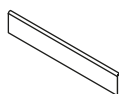

**GRADINO PLUS\***  
35x60cm / 13<sup>3/4</sup>"x24" rett

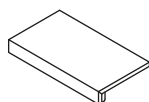

**ANGOLO DX / SX GRADINO PLUS\***  
35x35cm / 13<sup>3/4</sup>"x13<sup>3/4</sup>" rett

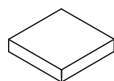

\* Su richiesta. / Upon request. /  
Sur demande. / auf Anfrage.

**DISTRICT****GRES TUTTA MASSA UGL**

Full-body porcelain / Grès Cérame pleine masse  
Vollgemischtes Durchgefärbtes Feinsteinzeug

**SPESSORE**

Thickness / Epaisseur / Stärke

**10 mm** (30x60 - 60x60)

**11 mm** (45x90 - 90x90)

**FUGA MINIMA CONSIGLIATA**

Minimum suggested joint

Joint minimum conseillé

Empfohlene Fugenbreite

**RECT**

2 mm (INDOOR)

**NON RECT**

3-4 mm Approx (INDOOR)

**OUTDOOR**

5-6 mm Approx (\*)

(\*) Decisione a cura della Direzione Lavori Codici di Posa Nazionali  
Decision by the Construction Manager / National Laying Standards  
Décision établie par la Direction des Travaux/Codes de Pose Nationaux  
Die Entscheidung wird von der Bauleitung/gemäß nationalen Vorschriften getroffen.

**STONALIZZAZIONE**

Shading / Denuançage / Spielfarbig

**ANSI A137.1****RESISTENZA ALLO SCIVOLAMENTO**

Slip resistance / Résistance au glissement

Rutschfestigkeit

**DIN 51130**

R10 (Nat) / R11 (Grip)

**DIN 51097**

B (A+B) (Nat) / C (A+B+C) (Grip)

**B.C.R. - TORTUS**

$\mu > 0,40$

**ANSI A326.3**

DCOF  $\geq 0.42$

**AS 4586:2013**

P4 (Grip)

**BS 7976:2002**

PTV 36+Wet (Sl. 96-55) (Grip)

**LEGENDA CODICI PRODOTTO / IMBALLI**

Legend product codes / Packing

Légende codes produits / Emballage

Legend Produktcodes / Verpackung

pag. 399/400

**P R ( ) T E C T**

ANTIBATTERICO - ANTIMICROBIAL

contemporary



**RIO COFFEE**  
60x60cm / 24"x24"  
nat



**MILANO ECRU**  
60x60cm / 24"x24"  
nat



bacchetta metal moka  
1,5x60cm / 5/8"x24"

# METROPOLIS

 gres porcellanato

**PROTECT**  
ANTIBATTERICO - ANTIMICROBIAL

spessore / thickness **10mm / 11mm**

**4**

**FORMATI** 

sizes / formats / Formate



30x60 cm / 12"x24" rett  
nat / texture grip



60x60cm/24"x24" rett  
nat / texture grip



45x90cm/18"x36" rett  
texture



90x90cm/36"x36" rett  
texture

**3**

**FINITURE**

finishes / surfaces / Oberfläche

**NAT**

**TEXTURE**

**TEXTURE GRIP**

**8**

**COLORI**

colors / couleurs / Farben

Tokyo White

London Gray

Paris Amande

Shanghai Iron

Milano Ecrú

Berlin Night

New York Coal

Rio Coffee

contemporary



# METROPOLIS

## NEW YORK COAL

60x60cm / 24"x24"

nat



212/  
213

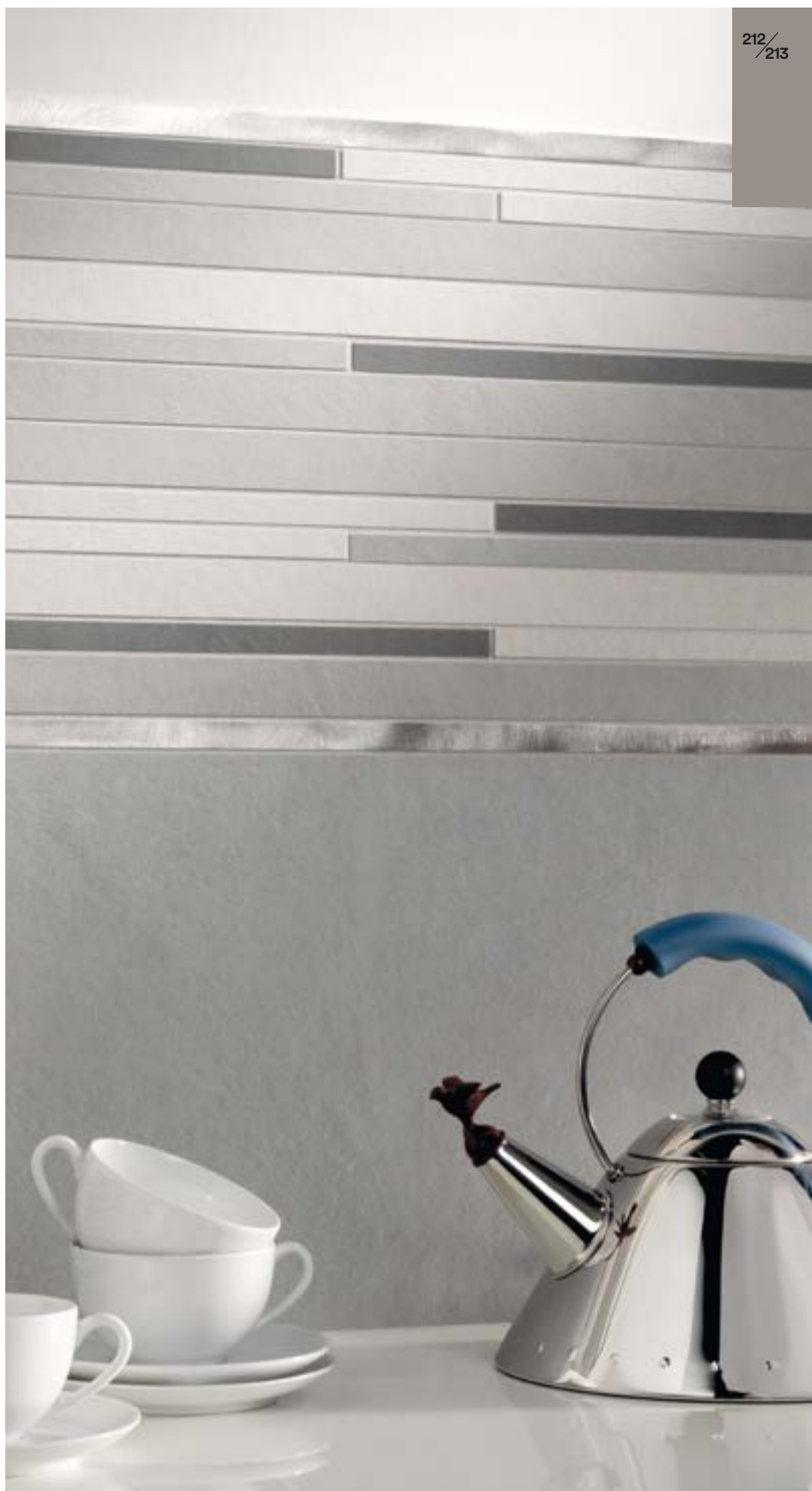

## SHANGHAI IRON

30x60cm / 12"x24"

nat



muretto urban cold  
30x60cm / 12"x24"

bacchetta metal titanio  
1,5x60cm / 5/8"x24"

contemporary

# METROPOLIS



**TOKYO WHITE**  
60x60cm / 24"x24"  
texture grip

---

30x60cm / 12"x24"  
texture grip







contemporary

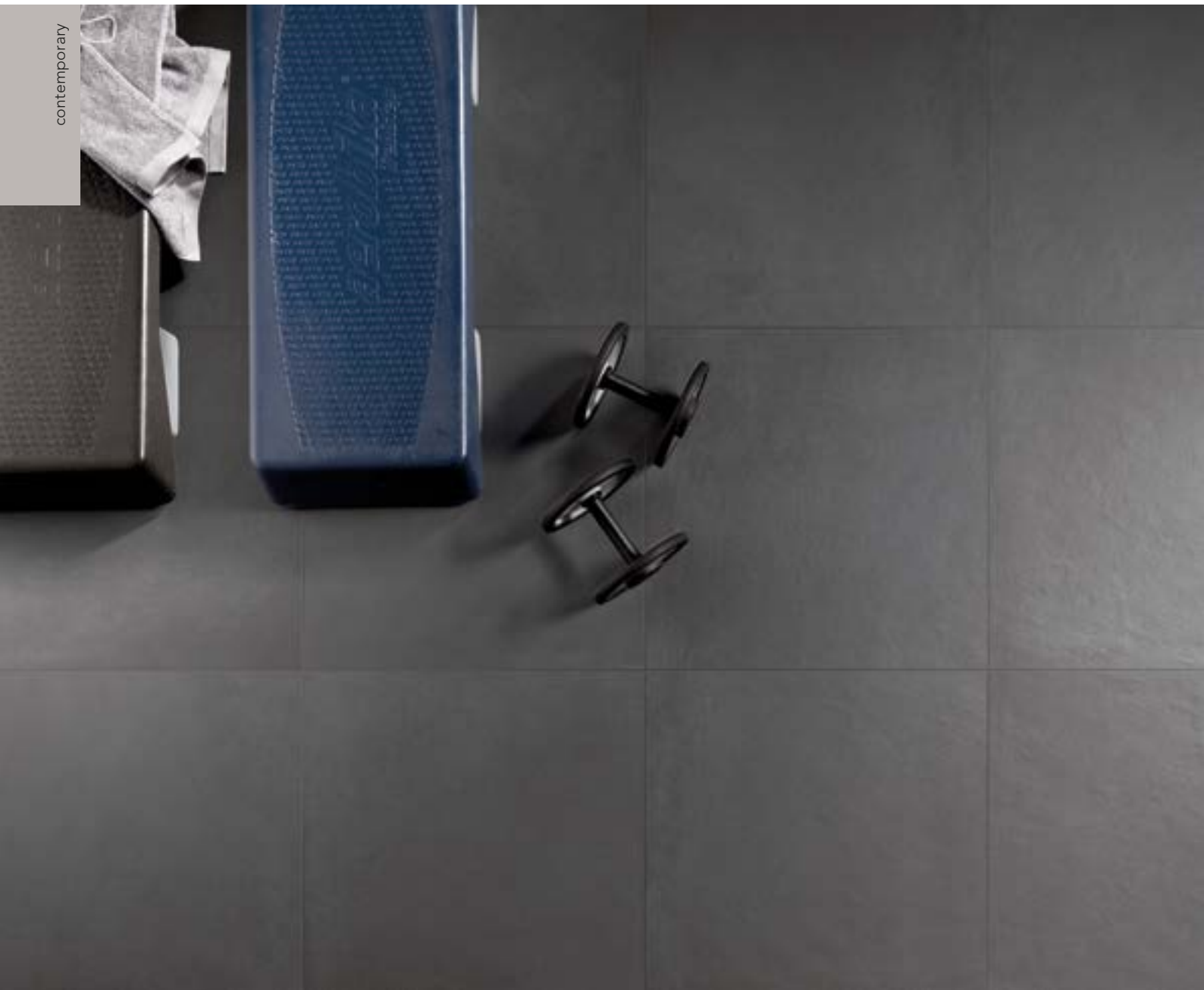

## METROPOLIS

**BERLIN NIGHT**  
60x60cm / 24"x24"  
nat





**LONDON GRAY**  
60x60cm / 24"x24"  
nat



# METROPOLIS

## DECORI E MOSAICI

decors and mosaics / décors et mosaïques / Dekore und Mosaïke

MURETTO AVENUE 3D  
30x60cm / 12"x24"  
tokyo white



MURETTO URBAN  
30x60cm / 12"x24"  
cold



MURETTO AVENUE 3D  
30x60cm / 12"x24"  
milano ecru



MURETTO URBAN  
30x60cm / 12"x24"  
warm



MURETTO AVENUE 3D  
30x60cm / 12"x24"  
shanghai iron



BACCHETTA METAL  
1,5x60cm / 5/8"x24"  
titanio



BACCHETTA METAL  
1,5x60cm / 5/8"x24"  
nero



MURETTO AVENUE 3D  
30x60cm / 12"x24"  
rio coffee



BACCHETTA METAL  
1,5x60cm / 5/8"x24"  
moka



MURETTO AVENUE 3D  
30x60cm / 12"x24"  
berlin night



**PEZZI SPECIALI**

trims / pièces spéciales  
Formstücke

**BATTISCOPIA**  
10x60cm / 4"x24" rett  
nat / texture grip

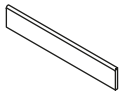

**GRADINO PLUS\***  
35x60cm / 13<sup>3/4</sup>"x24" rett  
nat / texture grip

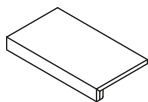

**ANGOLO SX / DX GRADINO PLUS\***  
35x35cm / 13<sup>3/4</sup>"x13<sup>3/4</sup>" rett  
nat / texture grip

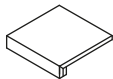
**METROPOLIS****GRES TUTTA MASSA UGL**

Full-body porcelain / Grès Cérame pleine masse  
Vollgemischtes Durchgefärbtes Feinsteinzeug

**SPESSORE**

Thickness / Epaisseur / Stärke

**10 mm** (30x60 - 60x60)

**11 mm** (45x90 - 90x90)

**FUGA MINIMA CONSIGLIATA**

Minimum suggested joint

Joint minimum conseillé

Empfohlene Fugenbreite

**RECT**

2 mm (INDOOR)

**NON RECT**

3-4 mm Approx (INDOOR)

**OUTDOOR**

5-6 mm Approx (\*)

(\*) Decisione a cura della Direzione Lavori Codici di Posa Nazionali  
Decision by the Construction Manager / National Laying Standards  
Décision établie par la Direction des Travaux/Codes de Pose Nationaux  
Die Entscheidung wird von der Bauleitung/gemäß nationalen Vorschriften getroffen.

**STONALIZZAZIONE**

Shading / Denuançage / Spielfarbig

**ANSI A137.1****RESISTENZA ALLO SCIVOLAMENTO**

Slip resistance / Résistance au glissement

Rutschfestigkeit

**DIN 51130**

R10 (Nat - Texture) / R11 (Texture Grip)

**DIN 51097**

C (A+B+C) (Texture Grip)

**B.C.R. - TORTUS**

$\mu > 0,40$

**ANSI A326.3**

DCOF  $\geq 0.42$

**AS 4586:2013**

P3 (Texture Grip)

**BS 7976:2002**

PTV 36+Wet (Sl. 96-55) (Texture Grip)

**LEGENDA CODICI PRODOTTO / IMBALLI**

Legend product codes / Packing

Légende codes produits / Emballage

Legend Produktcodes / Verpackung

pag. 405/406

**P R ( ) T E C T**

ANTIBATTERICO - ANTIMICROBIAL

\* Su richiesta. / Upon request. /  
Sur demande. / auf Anfrage.

contemporary



**PAPIRO BIANCO**  
2x60cm / 3/4"x24"

9,7x60cm / 3<sup>3</sup>/<sub>4</sub>"x24"

60x60cm / 24"x24"



wallpaper grey  
20x60cm / 8"x24"

# MAKÒ

 gres porcellanato

spessore / thickness **11mm**

## 5

**FORMATI** 

sizes / formats / Formate

□

2x2cm / 3/4"x3/4" rett



2x60cm / 3/4"x24" rett



9,7x60cm / 3<sup>3</sup>/<sub>4</sub>"x24" rett



30x60 cm / 12"x24" rett



60x60cm / 24"x24" rett

## 5

**COLORI**

colors / couleurs / Farben

Papiro Bianco

Yucca Grigio

Linen Beige

Java Scuro

Cedar Bruno



## MAKÒ

### **CEDAR BRUNO**

30x60cm / 12"x24"

decoro tartan  
30x60cm / 12"x24"



### **PAPIRO BIANCO**

60x60cm / 24"x24"

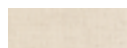

### **YUCCA GRIGIO**

30x60cm / 12"x24"

60x60cm / 24"x24"



decoro pin striped  
30x60cm / 12"x24"

decoro corset  
30x30cm / 12"x12"

fascia twill cold  
3x60cm / 1<sup>3</sup>/<sub>16</sub>"x24"





**DECORI**

decors / articles / Dekore

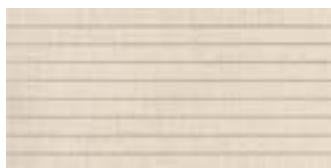
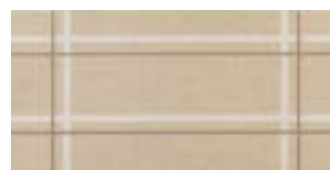
**DECORO PIN STRIPED**papiro bianco  
30x60cm / 12"x24"**DECORO CORSET**papiro bianco  
30x30cm / 12"x12"**DECORO PIN STRIPED**linen beige  
30x60cm / 12"x24"**DECORO CORSET**linen beige  
30x30cm / 12"x12"**DECORO CROSS**linen beige  
30x60cm / 12"x24"**DECORO PIN STRIPED**yucca grigio  
30x60cm / 12"x24"**DECORO CORSET**yucca grigio  
30x30cm / 12"x12"**DECORO CROSS**yucca grigio  
30x60cm / 12"x24"**DECORO PIN STRIPED**cedar bruno  
30x60cm / 12"x24"**DECORO CORSET**cedar bruno  
30x30cm / 12"x12"**DECORO TARTAN**cedar bruno  
30x60cm / 12"x24"**DECORO PIN STRIPED**java scuro  
30x60cm / 12"x24"**DECORO CORSET**java scuro  
30x30cm / 12"x12"**DECORO TARTAN**java scuro  
30x60cm / 12"x24"

**PEZZI SPECIALI**

trims / pièces spéciales  
Formstücke

**DECORO WALLPAPER**  
grey  
20x60cm / 8"x24"



**DECORO WALLPAPER**  
beige  
20x60cm / 8"x24"



**FASCIA TWILL**  
cold  
3x60cm / 1<sup>3</sup>/<sub>16</sub>"x24"



**FASCIA TWILL**  
warm  
3x60cm / 1<sup>3</sup>/<sub>16</sub>"x24"



**FASCIA BROCADE**  
cold  
3x60cm / 1<sup>3</sup>/<sub>16</sub>"x24"



**FASCIA BROCADE**  
warm  
3x60cm / 1<sup>3</sup>/<sub>16</sub>"x24"



**DECORO WALLFLOWER**  
cedar bruno  
papiro bianco  
linen beige  
yucca grigio  
java scuro  
30x60cm / 12"x24"



**BATTISCOPA**  
10x60cm / 4"x24" rett

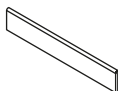

**GRADINO STEP**  
60x60cm / 24"x24" rett

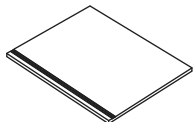

**RACCORDO JOLLY**  
1,3x30cm / 1/2"x12" rett



**BREAK JOLLY**  
1,3x1,3cm / 1/2"x1/2" rett

**MAKÒ****GRES SMALTATO A MASSA COLORATA GL**

Colored-body glazed porcelain / Grès émaillé a masse colorée / Glasiertes Feisteinzeug mit farbiger masse

**SPESSORE**

Thickness / Epaisseur / Stärke

**11 mm**

**FUGA MINIMA CONSIGLIATA**

Minimum suggested joint

Joint minimum conseillé

Empfohlene Fugenbreite

**RECT**

2 mm (INDOOR)

**NON RECT**

3-4 mm Approx (INDOOR)

**OUTDOOR**

5-6 mm Approx (\*)

(\*) Decisione a cura della Direzione Lavori Codici di Posa Nazionali  
Decision by the Construction Manager / National Laying Standards  
Décision établie par la Direction des Travaux/Codes de Pose Nationaux  
Die Entscheidung wird von der Bauleitung/gemäß nationalen Vorschriften getroffen.

**STONALIZZAZIONE**

Shading / Denuançage / Spielfarbig

**ANSI A137.1**

**RESISTENZA ALLO SCIVOLAMENTO**

Slip resistance / Résistance au glissement

Rutschfestigkeit

**DIN 51130**

**R9**

**B.C.R. - TORTUS**

$\mu > 0,40$

**RESISTENZA ALL'ABRASIONE  
SUPERFICIALE**

Resistance to superficial abrasion

Résistance à l'abrasion superficielle

Oberflächliche reibungsbeständigkeit

**ISO 10545-7**

**PEI 5** (papiro bianco/linen beige/yucca grigio)

**PEI 4** (cedar bruno/java scuro)

**LEGENDA CODICI PRODOTTO / IMBALLI**

Legend product codes / Packing

Légende codes produits / Emballage

Legend Produktcodes / Verpackung

**pag. 403/404**

contemporary



**SILT**  
60x60 cm / 24"x24"



# STONECLAY

 gres porcellanato

spessore / thickness **10mm**

**2**  
**FORMATI**

sizes / formats / Formate

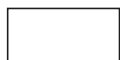

30x60 cm / 12"x24" rett



60x60cm / 24"x24" rett  
60,4x60,4cm / 24"x24" nat

**4**  
**COLORI**

colors / couleurs / Farben

 SYSTEM L2

spessore / thickness **20mm**



60x60cm / 24"x24" rett  
± 20mm

Silt

Lime

Charcoal

Cendre

contemporary

# STONECLAY



**LIME**  
30x60cm / 12"x24"



LEA CERAMICHE



contemporary

# STONECLAY

## CENDRE

60x60cm / 24"x24"





**MOSAICI**

mosaics / mosaïques / Mosaik

**MOSAICO**  
silt  
30x30cm / 12"x12"

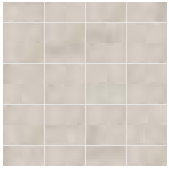

**MOSAICO**  
lime  
30x30cm / 12"x12"

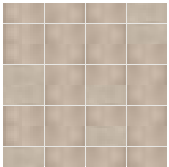

**MOSAICO**  
cendre  
30x30cm / 12"x12"

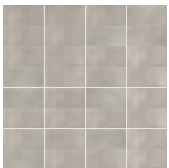

**MOSAICO**  
charcoal  
30x30cm / 12"x12"

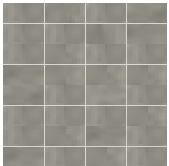
**PEZZI SPECIALI**

trims / pièces spéciales / Formstücke

**BATTISCOPIA**  
10x60cm / 4"x24" rett

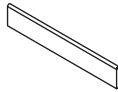

**GRADINO STEP**  
60x60cm / 24"x24" rett

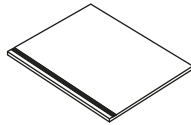
**STONECLAY****GRES TUTTA MASSA UGL**

Full-body porcelain / Grès Cérame pleine masse /  
Vollgemischtes Durchgefärbtes Feinsteinzeug

**SPESSORE**

Thickness / Epaisseur / Stärke

**10 mm** (30x60 - 60x60 - 60,4x60,4)**20 mm** (60x60)**FUGA MINIMA CONSIGLIATA**

Minimum suggested joint

Joint minimum conseillé

Empfohlene Fugenbreite

**RECT**

2 mm (INDOOR)

**NON RECT**

3-4 mm Approx (INDOOR)

**OUTDOOR**

5-6 mm Approx (\*)

(\*) Decisione a cura della Direzione Lavori Codici di Posa Nazionali

Decision by the Construction Manager / National Laying Standards

Décision établie par la Direction des Travaux/Codes de Pose Nationaux

Die Entscheidung wird von der Bauleitung/gemäß nationalen Vorschriften getroffen.

**STONALIZZAZIONE**

Shading / Denuançage / Spielfarbig

**ANSI A137.1****RESISTENZA ALLO SCIVOLAMENTO**

Slip resistance / Résistance au glissement

Rutschfestigkeit

**DIN 51130**

R10

**DIN 51097**

B (A+B)

**B.C.R. - TORTUS** $\mu > 0,40$ **ANSI A326.3**DCOF  $\geq 0.42$ **AS 4586:2013**

P3

**BS 7976:2002**

PTV 36+Wet (Sl. 96)

**LEGENDA CODICI PRODOTTO / IMBALLI**

Legend product codes / Packing

Légende codes produits / Emballage

Legend Produktcodes / Verpackung

pag. 409

stone



**NEXT GRAY**

60x120cm / 24"x48"  
nat



# NEXTONE

 gres porcellanato

**PROTECT**  
ANTIBATTERICO - ANTIMICROBIAL

spessore / thickness **10mm**

**4**  
**FORMATI**   
sizes / formats / Formate

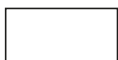

30x60cm / 12"x24" rett  
nat / lapp



60x60cm / 24"x24" rett  
nat / lapp / grip



60x120cm / 24"x48" rett  
nat / lapp

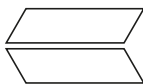

gramma 72  
49,8x14,5cm / 19<sup>1</sup>/<sub>2</sub>"x5<sup>45</sup>/<sub>64</sub>"  
nat

 **SYSTEM L2**

spessore / thickness **20mm**



60x60cm / 24"x24" rett  
≠ 20mm  
grip

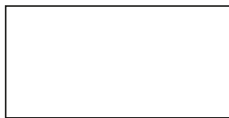

60x120cm / 24"x48" rett  
≠ 20mm  
grip

**3**  
**FINITURE**  
finishes / surfaces / Oberfläche

**NAT**

**LAPP**

**GRIP**

**3**  
**VARIANTI**  
variations / variantes / Varianten

**LINE**

**DOT**

**MARK**

**4**  
**COLORI**  
colors / couleurs / Farben

Next white

Next gray

Next taupe

Next dark

stone



## NEXTONE

### NEXT TAUPE

mosaico mix  
30x30cm / 24"x24"



### NEXT GRAY

60x120cm / 24"x48"  
nat

gramma 72

### MARK NEXT GRAY

30x60 cm / 12"x24"  
nat









**NEXTONE**

236/  
237

**NEXT WHITE**  
60x120cm / 24"x48"  
nat

**LINE NEXT WHITE**  
30x60 cm / 12"x24"  
nat

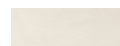

stone



## NEXTONE

**LINE NEXT DARK**  
30x60 cm / 12"x24"  
nat







**NEXT WHITE**  
60x120 cm / 24"x48"  
nat



stone

# NEXTONE



**NEXT DARK**  
60x120cm / 24"x48"  
lapp





stone



# NEXTONE

## NEXT TAUPE

60x60cm / 24"x24"

30x60cm / 12"x24"

nat

mosaico 144

30x30cm / 24"x24"

mosaico mix

30x30cm / 24"x24"

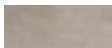

242/  
243



## NEXT TAUPE

mosaico 144

30x30cm / 24"x24"



# NEXTONE

## VARIANTI

variations / variantes / Varianten

### DOT

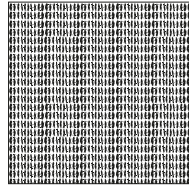

60x60cm / 24"x24" rett  
nat

### LINE

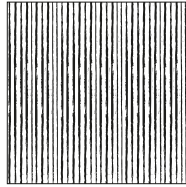

60x60cm / 24"x24" rett  
nat

### MARK

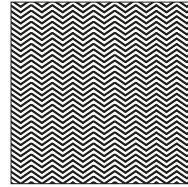

60x60cm / 24"x24" rett  
nat

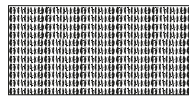

30x60cm / 12"x24" rett  
nat

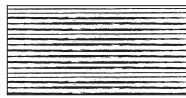

30x60cm / 12"x24" rett  
nat

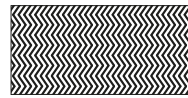

30x60cm / 12"x24" rett  
nat



**MARK NEXT GRAY**  
30x60 cm / 12"x24"  
nat

**LINE NEXT WHITE**  
60x60 cm / 24"x24"  
nat



**DOT NEXT GRAY**  
60x60 cm / 24"x24"  
nat



# NEXTONE

## MOSAICI

mosaics / mosaïques / Mosaik

## FORMATI SPECIALI

special sizes / formats spéciaux /  
Sonderformate

**MURETTO**  
30x60 cm / 12"x24" rett



**GRAMMA 72**  
49,8x14,5cm / 19<sup>1/2</sup>"x5<sup>45/64</sup>" rett



**MOSAICO MIX\***  
30x30 cm / 12"x12" rett



**MOSAICO 144**  
30x30 cm / 12"x12" rett



**\*superfici mixate: nat + dot + line + mark**  
superfici mixate: nat + dot + line + mark  
surfaces mixtes: nat + dot + line + mark  
gemischte Oberflächen: nat + dot + line + mark



**PEZZI SPECIALI**

trims / pièces spéciales / Formstücke

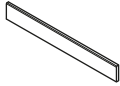
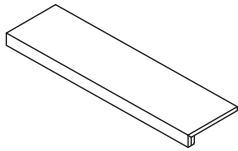
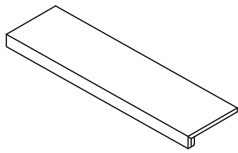
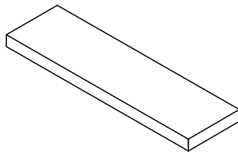
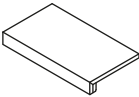
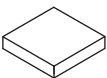
**BATTISCOPIA**5,5x60cm / 2<sup>11/64</sup>"x24" rett  
nat / lapp**GRADINO PLUS\***35x120cm / 13<sup>3/4</sup>"x48" rett  
nat / lapp**ANGOLO DX GRADINO PLUS\***35x120cm / 13<sup>3/4</sup>"x48" rett  
nat / lapp**ANGOLO SX GRADINO PLUS\***35x120cm / 13<sup>3/4</sup>"x48" rett  
nat / lapp**GRADINO PLUS\***35x60cm / 13<sup>3/4</sup>"x24" rett  
grip**ANGOLO GRADINO PLUS\***35x35cm / 13<sup>3/4</sup>"x13<sup>3/4</sup>" rett  
grip**NEXTONE****GRES TUTTA MASSA UGL**Full-body porcelain / Grès Cérame pleine masse  
Vollgemischtes Durchgefärbtes Feinsteinzeug**SPESSORE**

Thickness / Epaisseur / Stärke

**10 mm** (30x60 - 60x60 - 60x120)**20 mm** (60x60 - 60x120)**FUGA MINIMA CONSIGLIATA**

Minimum suggested joint

Joint minimum conseillé

Empfohlene Fugenbreite

**RECT**

2 mm (INDOOR)

**NON RECT**

3-4 mm Approx (INDOOR)

**OUTDOOR**

5-6 mm Approx (\*)

(\*) Decisione a cura della Direzione Lavori Codici di Posa Nazionali

Decision by the Construction Manager / National Laying Standards

Décision établie par la Direction des Travaux/Codes de Pose Nationaux

Die Entscheidung wird von der Bauleitung/gemäß nationalen Vorschriften getroffen.

**STONALIZZAZIONE**

Shading / Denuançage / Spielfarbig

**ANSI A137.1****RESISTENZA ALLO SCIVOLAMENTO**

Slip resistance / Résistance au glissement

Rutschfestigkeit

**DIN 51130**

R10 (Nat) / R11 (Grip - 20mm)

**DIN 51097**

B (A+B) (Nat) / C (A+B+C) (Grip - 20mm)

**B.C.R. - TORTUS** $\mu > 0,40$  (Nat - Grip - 20mm)**ANSI A326.3**DCOF  $\geq 0.42$ **AS 4586:2013**

P3 (Nat) / P4 (Grip - 20mm)

**BS 7976:2002**

PTV 36+Wet (Sl. 96) (Nat)

PTV 36+Wet (Sl. 55) (Grip, 20mm)

**LEGENDA CODICI PRODOTTO / IMBALLI**

Legend product codes / Packing

Légende codes produits / Emballage

Legend Produktcodes / Verpackung

pag. 407/408

**PROTECT**

ANTIBATTERICO - ANTIMICROBIAL

\* Su richiesta. / Upon request. /  
Sur demande. / auf Anfrage.

stone



**SILVER FLOW**

60x60cm / 24"x24"  
lapp



**GRAY FLOW**

brick  
30x60cm / 12"x24"  
lapp



# WATERFALL

 gres porcellanato | **PROTECT**  
ANTIBATTERICO - ANTIMICROBIAL

spessore / thickness **10,5mm**

## 8

### FORMATI $\text{LRT}^{\text{T}}$

sizes / formats / Formate

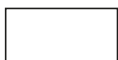

30x60cm / 12"x24" rett  
nat / lapp

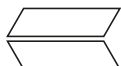

gramma 72  
49,8x14,5cm / 19<sup>1/2</sup>"x5<sup>5/64</sup>" rett  
nat



60x60cm / 24"x24" rett  
nat / lapp / grip

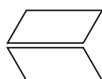

gramma 66 sx e dx  
39,2x16,9cm / 15<sup>3/8</sup>"x6<sup>5/8</sup>" rett  
nat

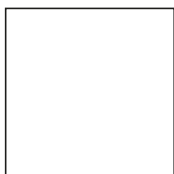

90x90cm / 36"x36" rett  
nat / lapp



gramma 16 sx e dx  
19,5x8,3cm / 7<sup>5/8</sup>"x3<sup>17/64</sup>" rett  
nat



45x90cm / 18"x36" rett  
nat / lapp



60x120cm / 24"x48" rett  
nat / lapp

 **SYSTEM L2**

spessore / thickness **20mm**



60x60cm / 24"x24" rett  
± 20mm  
grip



45x90cm / 18"x36" rett  
± 20mm  
grip

## 3

### FINITURE

finishes / surfaces / Oberfläche

**NAT**

**LAPP**

**GRIP**

## 4

### COLORI

colors / couleurs / Farben

Ivory flow

Silver flow

Gray flow

Dark flow

stone



## WATERFALL

CHEVRON

GRAY FLOW  
gramma 72  
nat

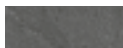



**IVORY FLOW**  
90x90cm / 36"x36"  
nat



stone





## WATERFALL

### DARK FLOW

mosaico 36  
30x30cm / 12"x12"  
lapp



### DARK FLOW

60x60cm / 24"x24"  
lapp



stone





# WATERFALL

## ARROW

---

### SILVER FLOW

gramma 16 dx e sx  
nat

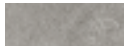

### DARK FLOW

gramma 16 dx e sx  
nat



**IVORY FLOW**  
muretto 3D  
30x60cm / 12"x24"  
lapp



254/  
255

stone

# WATERFALL



## BASKET

---

### SILVER FLOW

gramma 16 dx  
nat

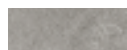

### DARK FLOW

gramma 66 sx  
nat





# WATERFALL

## MOSAICI

mosaics / mosaïques / Mosaik

**MURETTO**  
30x60 cm / 12"x24" rett



**BRICK**  
30x60 cm / 12"x24" rett



**MURETTO 3D**  
30x60 cm / 12"x24" rett



**MOSAICO 36**  
30x30 cm / 12"x12" rett



## FORMATI SPECIALI

special sizes / formats spéciaux /  
Sonderformate

**GRAMMA 72**  
49,8x14,5cm / 19<sup>1</sup>/<sub>2</sub>"x5<sup>45</sup>/<sub>64</sub>" rett

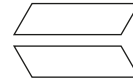

**GRAMMA 66 DX**  
39,2x16,9cm / 15<sup>3</sup>/<sub>8</sub>"x6<sup>5</sup>/<sub>8</sub>" rett



**GRAMMA 66 SX**  
39,2x16,9cm / 15<sup>3</sup>/<sub>8</sub>"x6<sup>5</sup>/<sub>8</sub>" rett



**GRAMMA 16 DX**  
19,5x8,3cm / 7<sup>5</sup>/<sub>8</sub>"x3<sup>17</sup>/<sub>64</sub>" rett



**GRAMMA 16 SX**  
19,5x8,3cm / 7<sup>5</sup>/<sub>8</sub>"x3<sup>17</sup>/<sub>64</sub>" rett



## COMPOSIZIONI A MODULI SFUSI

tile layouts in loose modules / compositions en modules en vrac / Kompositionen mit Einzelmodulen

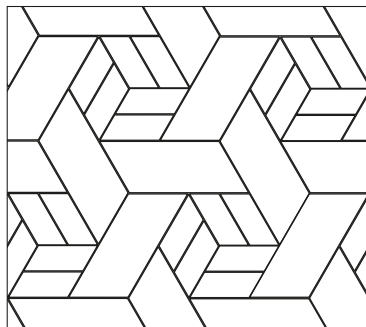

**BASKET** Gramma 66 SX 67%  
Gramma 16 DX 33%

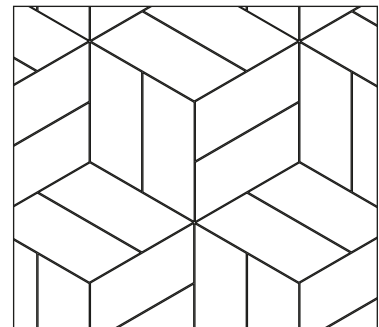

**TWIST** Gramma 66 DX 100%

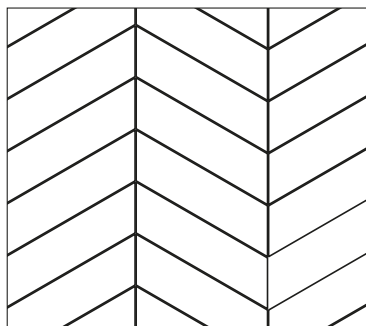

**CHEVRON** Gramma 72 100%

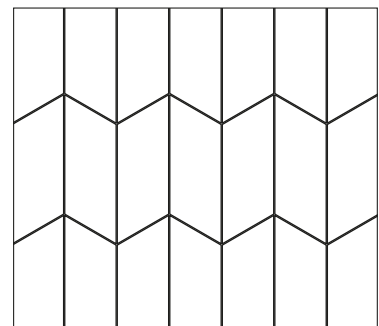

**ARROW** Gramma 66 DX 50% e SX 50%

**PEZZI SPECIALI**

trims / pièces spéciales / Formstücke

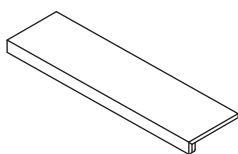
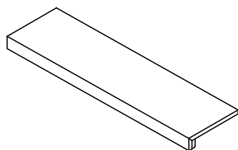
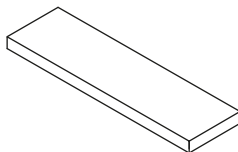
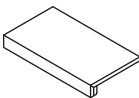
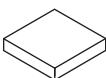
**BATTISCOPIA**10x60cm / 4"x24" rett  
nat / lapp**GRADINO PLUS\***35x120cm / 13<sup>3/4</sup>"x48" rett  
nat / lapp**ANGOLO DX GRADINO PLUS\***35x120cm / 13<sup>3/4</sup>"x48" rett  
nat / lapp**ANGOLO SX GRADINO PLUS\***35x120cm / 13<sup>3/4</sup>"x48" rett  
nat / lapp**GRADINO PLUS\***35x60cm / 13<sup>3/4</sup>"x24" rett  
grip**ANGOLO GRADINO PLUS\***35x35cm / 13<sup>3/4</sup>"x13<sup>3/4</sup>" rett  
grip

\* Su richiesta. / Upon request. /  
Sur demande. / auf Anfrage.

**WATERFALL****GRES TUTTA MASSA UGL**Full-body porcelain / Grès Cérame pleine masse  
Vollgemischtes Durchgefärbtes Feinsteinzeug**SPESSORE**

Thickness / Epaisseur / Stärke

**10,5 mm** (30x60 - 60x60 - 45x90 - 90x90 - 60-120)  
**20 mm** (60x60 - 45x90)

**FUGA MINIMA CONSIGLIATA**

Minimum suggested joint

Joint minimum conseillé

Empfohlene Fugenbreite

**RECT**

2 mm (INDOOR)

**NON RECT**

3-4 mm Approx (INDOOR)

**OUTDOOR**

5-6 mm Approx (\*)

(\*) Decisione a cura della Direzione Lavori Codici di Posa Nazionali  
Decision by the Construction Manager / National Laying Standards  
Décision établie par la Direction des Travaux/Codes de Pose Nationaux

Die Entscheidung wird von der Bauleitung/gemäß nationalen Vorschriften getroffen.

**STONALIZZAZIONE**

Shading / Denuançage / Spielfarbig

**ANSI A137.1****RESISTENZA ALLO SCIVOLAMENTO**

Slip resistance / Résistance au glissement

Rutschfestigkeit

**DIN 51130**

R10 (Nat) / R11 (Grip - 20mm)

**DIN 51097**

B (A+B) (Nat)

C (A+B+C) (Grip - 20mm)

**B.C.R. - TORTUS** $\mu > 0,40$  (Nat - Grip - 20mm)**ANSI A326.3**DCOF  $\geq 0.42$  (Nat - Grip - 20mm)**AS 4586:2013**

P3 (Nat)

P4 (Grip - 20mm)

**BS 7976:2002**

PTV 36+Wet (Sl. 96) (Nat)

**LEGENDA CODICI PRODOTTO / IMBALLI**

Legend product codes / Packing

Légende codes produits / Emballage

Legend Produktcodes / Verpackung

pag. 416/417

**P R ( ) T E C T**

ANTIBATTERICO - ANTIMICROBIAL

stone



**GREY TENERIFE**

60x90cm / 24"x36"  
nat

60x60cm / 24"x24"  
nat

40x60cm / 16"x24"  
nat

30x60cm / 12"x24"  
nat

20x60cm / 8"x24"  
nat



# CLIFFSTONE

 gres porcellanato

**PROTECT**  
ANTIBATTERICO - ANTIMICROBIAL

spessore / thickness **10mm / 11mm**

**7**  
**FORMATI**   
sizes / formats / Formate

**4**  
**FINITURE**  
finishes / surfaces / Oberfläche

**4**  
**COLORI**  
colors / couleurs / Farben

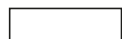

20x60cm / 8"x24" rett  
lapp / nat / ant



30x60cm / 12"x24" rett  
lapp / nat / ant



40x60cm / 16"x24" rett  
lapp / nat / ant



60x60cm / 24"x24" rett  
lapp / nat / ant / grip

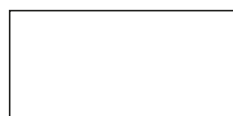

60x120cm / 24"x48" rett  
lapp / nat / ant



60x90cm / 24"x36" rett  
lapp / nat / ant

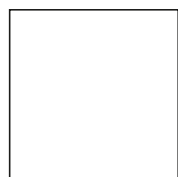

90x90cm / 36"x36" rett  
lapp / nat / ant

**LAPP**

**NAT**

**ANT**

**GRIP**



White Dover

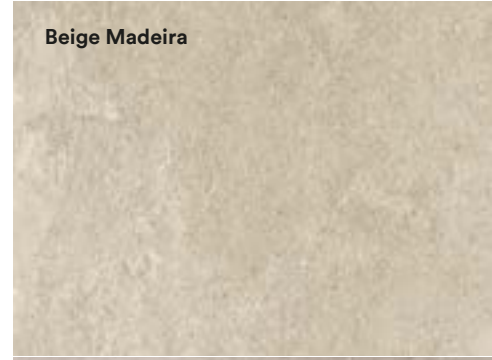

Beige Madeira



Taupe Moher

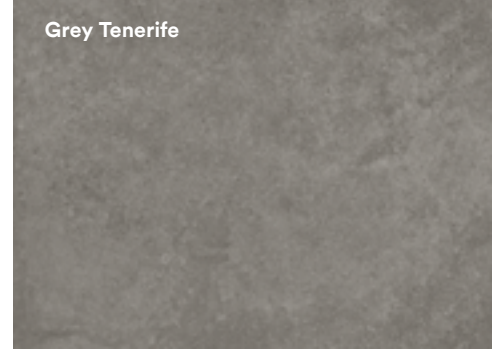

Grey Tenerife

 **SYSTEM L2**

spessore / thickness **20mm**



60x60cm / 24"x24" rett  
≡ 20mm  
grip







# CLIFFSTONE

262/  
263

**WHITE DOVER**  
90x90cm / 36"x36"  
lapp



stone



## CLIFFSTONE

**WHITE DOVER**  
60x120cm / 24"x48"  
ant

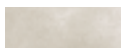

**BEIGE MADEIRA**  
60x90cm / 24"x36"  
ant  
60x60cm / 24"x24"  
ant  
40x60cm / 16"x24"  
ant  
30x60cm / 12"x24"  
ant  
20x60cm / 8"x24"  
ant





stone



# CLIFFSTONE

## TAUPE MOHER

60x120cm / 24"x48"  
lapp

60x90cm / 24"x36"  
lapp

60x60cm / 24"x24"  
lapp

30x60cm / 12"x24"  
lapp



**TAUPE MOHER**  
60x120cm / 24"x48"  
nat



# CLIFFSTONE

## GREY TENERIFE

60x90cm / 24"x36"  
nat

60x60cm / 24"x24"  
nat

40x60cm / 16"x24"  
nat

30x60cm / 12"x24"  
nat

20x60cm / 8"x24"  
nat





**WHITE DOVER**  
90x90cm / 36"x36"  
nat



# CLIFFSTONE

## MOSAICI

mosaics / mosaïques / Mosaik

**MURETTO**  
white dover lapp.  
30x60cm / 12"x24"



**MOSAICO 16**  
white dover lapp.  
30x30cm / 12"x12"

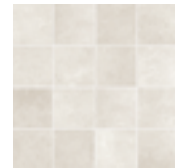

**MURETTO**  
beige madeira lapp.  
30x60cm / 12"x24"



**MOSAICO 16**  
beige madeira lapp.  
30x30cm / 12"x12"



**MURETTO**  
taupe moher lapp.  
30x60cm / 12"x24"



**MOSAICO 16**  
taupe moher lapp.  
30x30cm / 12"x12"

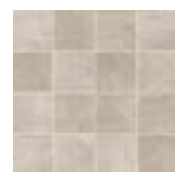

**MURETTO**  
grey tenerife lapp.  
30x60cm / 12"x24"



**MOSAICO 16**  
grey tenerife lapp.  
30x30cm / 12"x12"





**PEZZI SPECIALI**

trims / pièces spéciales / Formstücke

**BATTISCOPIA**  
10x60cm / 4"x24" rett  
nat / lapp / ant

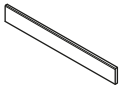

**GRADINO PLUS\***  
35x120cm / 13<sup>3/4</sup>"x48" rett  
nat / lapp / ant

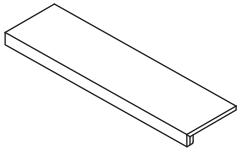

**ANGOLO DX GRADINO PLUS\***  
35x120cm / 13<sup>3/4</sup>"x48" rett  
nat / lapp / ant

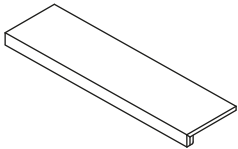

**ANGOLO SX GRADINO PLUS\***  
35x120cm / 13<sup>3/4</sup>"x48" rett  
nat / lapp / ant

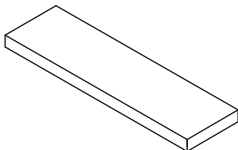

**GRADINO PLUS\***  
35x60cm / 13<sup>3/4</sup>"x24" rett  
grip

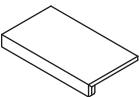

**ANGOLO GRADINO PLUS\***  
35x35cm / 13<sup>3/4</sup>"x13<sup>3/4</sup>" rett  
grip

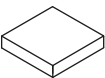

\* Su richiesta. / Upon request. /  
Sur demande. / auf Anfrage.

**CLIFFSTONE****GRES TUTTA MASSA UGL**

Full-body porcelain / Grès Cérame pleine masse  
Vollgemischtes Durchgefärbtes Feinsteinzeug

**SPESSORE**

Thickness / Epaisseur / Stärke

**10 mm**

**11 mm (90x90)**

**20 mm (60x60)**

**FUGA MINIMA CONSIGLIATA**

Minimum suggested joint

Joint minimum conseillé

Empfohlene Fugenbreite

**RECT**

2 mm (INDOOR)

**NON RECT**

3-4 mm Approx (INDOOR)

**OUTDOOR**

5-6 mm Approx (\*)

(\*) Decisione a cura della Direzione Lavori Codici di Posa Nazionali  
Decision by the Construction Manager / National Laying Standards  
Décision établie par la Direction des Travaux/Codes de Pose Nationaux  
Die Entscheidung wird von der Bauleitung/gemäß nationalen Vorschriften getroffen.

**STONALIZZAZIONE**

Shading / Denuançage / Spielfarbig

**ANSI A137.1****RESISTENZA ALLO SCIVOLAMENTO**

Slip resistance / Résistance au glissement

Rutschfestigkeit

**DIN 51130**

R10 (Nat - Ant) / R11 (Grip - 20mm)

**DIN 51097**

B (A+B) (Nat - Ant)

C (A+B+C) (Grip - 20mm)

**B.C.R. - TORTUS**

$\mu > 0,40$  (Nat - Ant - Grip - 20mm)

**ANSI A326.3**

DCOF  $\geq 0.42$

**AS 4586:2013**

P3 (Nat - Ant)

P4 (Grip - 20mm)

**BS 7976:2002**

PTV 36+Wet (Sl. 96) (Nat - Ant)

**LEGENDA CODICI PRODOTTO / IMBALLI**

Legend product codes / Packing

Légende codes produits / Emballage

Legend Produktcodes / Verpackung

pag. 397/398

**P R O T E C T**

ANTIBATTERICO - ANTIMICROBIAL

stone



**TEXTURE**

60x60 cm / 24"x24"

nat

30x60 cm / 12"x24"

nat



# BASALTINA STONE PROJECT

 gres porcellanato

spessore / thickness 11mm / 12mm

### 3

**FORMATI** 

sizes / formats / Formate



30x60 cm / 12"x24" rett

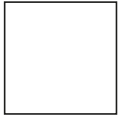

60x60cm / 24"x24" rett



60x120cm / 24"x48" rett

### 2

**FINITURE**

finishes / surfaces / Oberfläche

**NAT**

**LEV**

### 7

**COLORI**

colors / couleurs / Farben

Scalpellata

Naturale

Sabbiata

Stuccata

Sabbiata Velvet

Lappata

Texture



# BASALTINA STONE PROJECT

**SCALPELLATA**  
30x60cm / 12"x24"  
nat



**STUCCATA**  
60x60cm / 24"x24"  
nat



**SCALPELLATA**  
30x60cm / 12"x24"  
nat



274/  
275



# BASALTINA STONE PROJECT

## MOSAICI

mosaics / mosaïques / Mosaik

**MOSAICO 1**  
sabbiaia  
28,5x28,5cm / 11<sup>1/4</sup>"x11<sup>1/4</sup>"

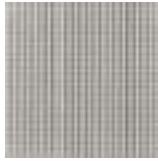

**MURETTO**  
sabbiaia  
30x60cm / 12"x24"



**MOSAICO 1**  
sabbiaia velvet  
28,5x28,5cm / 11<sup>1/4</sup>"x11<sup>1/4</sup>"

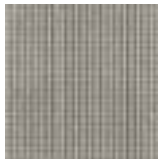

**MURETTO**  
sabbiaia velvet  
30x60cm / 12"x24"



**MOSAICO 1**  
naturale  
28,5x28,5cm / 11<sup>1/4</sup>"x11<sup>1/4</sup>"

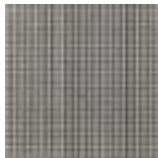

**MURETTO**  
naturale  
30x60cm / 12"x24"



**MOSAICO 1**  
stuccata  
28,5x28,5cm / 11<sup>1/4</sup>"x11<sup>1/4</sup>"

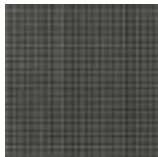

**MURETTO**  
stuccata  
30x60cm / 12"x24"



**MOSAICO 1**  
lappata  
28,5x28,5cm / 11<sup>1/4</sup>"x11<sup>1/4</sup>"



**MURETTO**  
lappata  
30x60cm / 12"x24"



**LAPPATA**  
30x60cm / 12"x24"mosaico 1  
28,5x28,5cm / 11<sup>1</sup>/<sub>4</sub>"x11<sup>1</sup>/<sub>4</sub>"**PEZZI SPECIALI**

trims / pièces spéciales / Formstücke

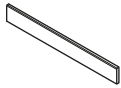
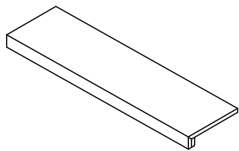
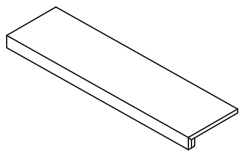
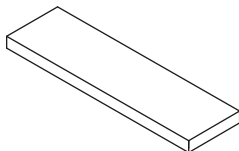
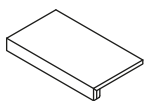
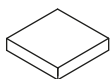
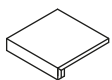
**BATTISCOPIA**  
10x60cm / 4"x24" rett**GRADINO PLUS\***  
35x120cm / 13<sup>3</sup>/<sub>4</sub>"x48" rett**ANGOLO DX GRADINO PLUS\***  
35x120cm / 13<sup>3</sup>/<sub>4</sub>"x48" rett**ANGOLO SX GRADINO PLUS\***  
35x120cm / 13<sup>3</sup>/<sub>4</sub>"x48" rett**GRADINO PLUS\***  
35x60cm / 13<sup>3</sup>/<sub>4</sub>"x24" rett**ANGOLO DX GRADINO PLUS\***  
35x35cm / 13<sup>3</sup>/<sub>4</sub>"x13<sup>3</sup>/<sub>4</sub>" rett**ANGOLO SX GRADINO PLUS\***  
35x35cm / 13<sup>3</sup>/<sub>4</sub>"x13<sup>3</sup>/<sub>4</sub>" rett**RACCORDO JOLLY**  
1,3x30cm / 1/2"x12" rett**BREAK JOLLY**  
1,3x1,3cm / 1/2"x1/2" rett\* Su richiesta. / Upon request. /  
Sur demande. / auf Anfrage.

# BASALTINA STONE PROJECT





**BASALTINA STONE PROJECT****GRES TUTTA MASSA UGL**

Full-body porcelain / Grès Cérame pleine masse  
Vollgemischtes Durchgefärbtes Feinsteinzeug

**SPESSORE**

Thickness / Epaisseur / Stärke

**11 mm (30x60 - 60x60)**

**12 mm (60x120)**

**FUGA MINIMA CONSIGLIATA**

Minimum suggested joint

Joint minimum conseillé

Empfohlene Fugenbreite

**RECT**

2 mm (INDOOR)

**NON RECT**

3-4 mm Approx (INDOOR)

**OUTDOOR**

5-6 mm Approx (\*)

(\*) Decisione a cura della Direzione Lavori Codici di Posa Nazionali

Decision by the Construction Manager / National Laying Standards

Décision établie par la Direction des Travaux/Codes de Pose Nationaux

Die Entscheidung wird von der Bauleitung/gemäß nationalen Vorschriften getroffen.



**V3**

**STONALIZZAZIONE**

Shading / Denuançage / Spielfarbig

**ANSI A137.1****RESISTENZA ALLO SCIVOLAMENTO**

Slip resistance / Résistance au glissement

Rutschfestigkeit

**DIN 51130**

**R10** (Naturale - Stuccata - Texture Nat

Sabbiata Velvet)

**R11** (Sabbiata - Scalpellata)

**DIN 51097**

**C (A+B+C)** (Sabbiata - Scalpellata)

**B.C.R. - TORTUS**

$\mu > 0,40$  (Naturale - Stuccata - Texture Nat

Sabbiata - Sabbiata Velvet - Scalpellata)

**ANSI A326.3**

**DCOF  $\geq 0.42$**  (Naturale - Stuccata - Texture Nat

Sabbiata - Sabbiata Velvet - Sabbiata)

**AS 4586:2013**

**P4** (Sabbiata - Scalpellata)

**BS 7976:2002**

**PTV 36+Wet (Sl. 96-55)** (Sabbiata - Scalpellata)

**LEGENDA CODICI PRODOTTO / IMBALLI**

Legend product codes / Packing

Légende codes produits / Emballage

Legend Produktcodes / Verpackung

pag. 392



IT / 021 / 010

**NATURALE**

30x60cm / 12" x24"

nat

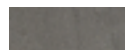
**SABBIATA**

60x60cm / 24" x24"

nat



stone



**DORAL**

20x30cm / 8"x12"

30x30cm / 12"x12"

30x60cm / 12"x24"



# TECNOQUARTZ

 gres porcellanato

spessore / thickness **12mm**

**6**

**FORMATI** 

sizes / formats / Formate

**4**

**COLORI**

colors / couleurs / Farben



20x30cm / 8"x12" rett



30x30cm / 12"x12" rett



20x60cm / 8"x24" rett



30x60cm / 12"x24" rett



40x60cm / 16"x24" rett



60x60cm / 24"x24" rett

**Doral**



**Silver**



**Gneiss**

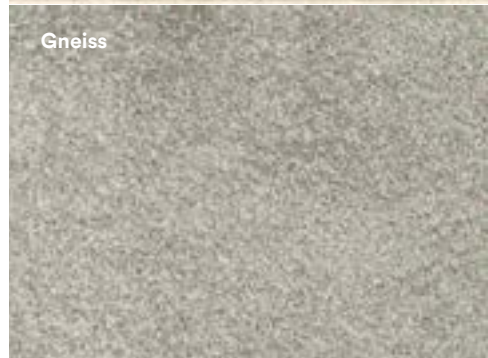

**Hard black**

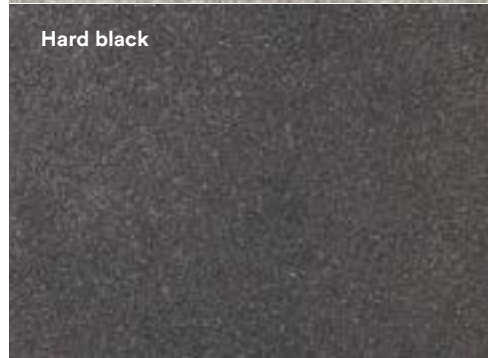

stone





## TECNOQUARTZ

### SILVER

20x60cm / 8"x24"

20x30cm / 8"x12"



### GNEISS

30x30cm / 12"x12"

30x60cm / 12"x24"

60x60cm / 24"x24"



**MOSAICI**

mosaics / mosaïques / Mosaik

**LISTONE LINK**  
doral  
30x60 cm / 12"x24"



**LISTONE LINK**  
silver  
30x60 cm / 12"x24"



**MURETTO**  
doral  
30x60 cm / 12"x24"



**MURETTO**  
silver  
30x60 cm / 12"x24"



**MOSAICO ANTICATO 7**  
doral  
29,3x29,3 cm / 11<sup>1</sup>/<sub>2</sub>"x11<sup>1</sup>/<sub>2</sub>"



**MOSAICO ANTICATO 7**  
silver  
29,3x29,3 cm / 11<sup>1</sup>/<sub>2</sub>"x11<sup>1</sup>/<sub>2</sub>"



**ANTICATO 14**  
doral  
14,5x14,5 cm / 5<sup>3</sup>/<sub>4</sub>"x5<sup>3</sup>/<sub>4</sub>"



**ANTICATO 14**  
silver  
14,5x14,5 cm / 5<sup>3</sup>/<sub>4</sub>"x5<sup>3</sup>/<sub>4</sub>"



**ANTICATO 7x14**  
doral  
7,1x14,5 cm / 2<sup>3</sup>/<sub>4</sub>"x5<sup>3</sup>/<sub>4</sub>"



**ANTICATO 7x14**  
silver  
7,1x14,5 cm / 2<sup>3</sup>/<sub>4</sub>"x5<sup>3</sup>/<sub>4</sub>"



**PEZZI SPECIALI**

trims / pièces spéciales / Formstücke

**LISTONE LINK**  
gneiss  
30x60 cm / 12"x24"



**LISTONE LINK**  
hard black  
30x60 cm / 12"x24"



**BATTISCOPA**  
8x60cm / 3 1/2"x24" rett

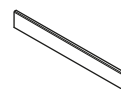

**MURETTO**  
gneiss  
30x60 cm / 12"x24"



**MURETTO**  
hard black  
30x60 cm / 12"x24"



**GRADINO PLUS\***  
35x60cm / 13 3/4"x24" rett

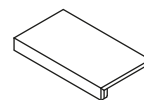

**ANGOLO DX GRADINO PLUS\***  
35x35cm / 13 3/4"x13 3/4" rett

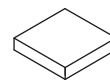

**MOSAICO ANTICATO 7**  
gneiss  
29,3x29,3 cm / 11 1/2"x11 1/2"



**MOSAICO ANTICATO 7**  
hard black  
29,3x29,3 cm / 11 1/2"x11 1/2"

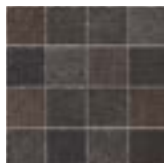

**ANGOLO SX GRADINO PLUS\***  
35x35cm / 13 3/4"x13 3/4" rett

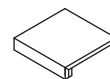

**ANTICATO 14**  
gneiss  
14,5x14,5 cm / 5 3/4"x5 3/4"



**ANTICATO 14**  
hard black  
14,5x14,5 cm / 5 3/4"x5 3/4"



**RACCORDO JOLLY**  
1,2x30cm / 1/2"x12" rett



**BREAK JOLLY**  
1,2x1,2cm / 1/2"x1/2" rett



**ANTICATO 7x14**  
gneiss  
7,1x14,5 cm / 2 3/4"x5 3/4"



**ANTICATO 7x14**  
hard black  
7,1x14,5 cm / 2 3/4"x5 3/4"



\* Su richiesta. / Upon request. /  
Sur demande. / auf Anfrage.

# TECNOQUARTZ





## TECNOQUARTZ

### GRES TUTTA MASSA UGL

Full-body porcelain / Grès Cérame pleine masse  
Vollgemischtes Durchgefärbtes Feinsteinzeug

### SPESSORE

Thickness / Epaisseur / Stärke  
**12 mm**

### FUGA MINIMA CONSIGLIATA

Minimum suggested joint  
Joint minimum conseillé  
Empfohlene Fugenbreite

#### RECT

2 mm (INDOOR)

#### NON RECT

3-4 mm Approx (INDOOR)

#### OUTDOOR

5-6 mm Approx (\*)

(\*) Decisione a cura della Direzione Lavori Codici di Posa Nazionali  
Decision by the Construction Manager / National Laying Standards  
Décision établie par la Direction des Travaux/Codes de Pose Nationaux  
Die Entscheidung wird von der Bauleitung/gemäß nationalen Vorschriften getroffen.



### STONALIZZAZIONE

Shading / Denuançage / Spielfarbig

**ANSI A137.1**

### RESISTENZA ALLO SCIVOLAMENTO

Slip resistance / Résistance au glissement  
Rutschfestigkeit

#### DIN 51130

R10 (Doral - Silver - Gneiss)

R11 (Hard black)

#### DIN 51097

B (A+B)

#### B.C.R. - TORTUS

$\mu > 0,40$

#### ANSI A326.3

DCOF  $\geq 0.42$

### DOPPIA PRESSATURA

Double pressed / Double passage / Doppelte  
pressung

### LEGENDA CODICI PRODOTTO / IMBALLI

Legend product codes / Packing  
Légende codes produits / Emballage  
Legend Produktcodes / Verpackung

**pag. 413/414**



IT / 021 / 010

### HARD BLACK

20x30cm / 8"x12"  
20x60cm / 8"x24"  
30x30cm / 12"x12"  
30x60cm / 12"x24"  
60x60cm / 24"x24"



marble



**LASA  
AURORA**  
58x116cm / 23"x46"  
lux



# DREAMING

 gres porcellanato

spessore / thickness 10mm / 11 mm

## 4

### FORMATI

sizes / formats / Formate



30x60cm / 12"x24" rett  
velvet / lux

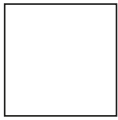

60x60cm / 24"x24" rett  
velvet / lux

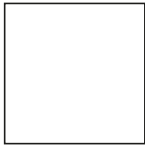

75x75cm / 30"x30" rett  
velvet  
73x73cm / 29"x29" rett  
lux

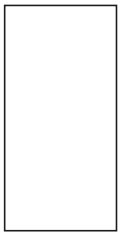

\*60x120cm / 24"x48" rett  
velvet

\*58x116cm / 23"x46" rett  
lux

## 2

### FINITURE

finishes / surfaces / Oberfläche

#### LUX

#### VELVET

## 8

### COLORI

colors / couleurs / Farben

Imperial Onyx



Lasa Aurora

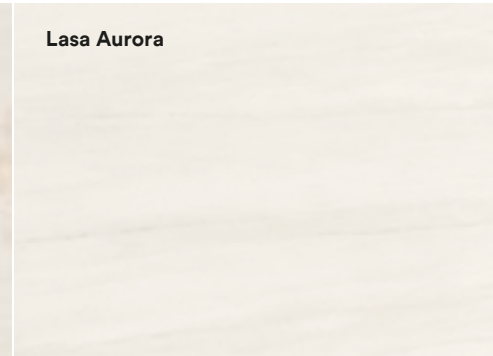

Bianco Statuario



Crystal White



Romance Safari

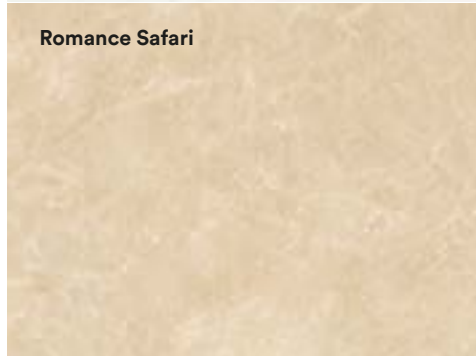

Passion Pulpis

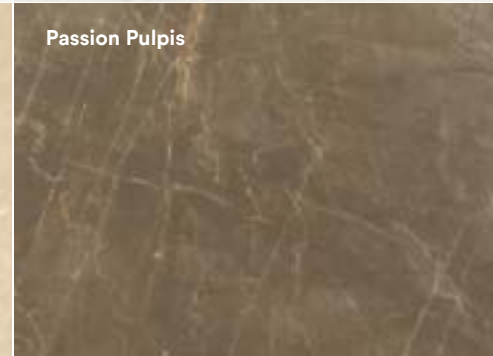

Calacatta Shine



Gray Stone

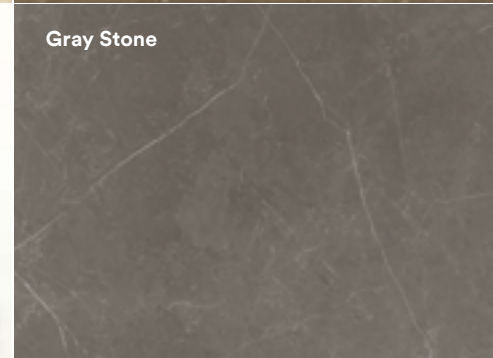

**\* colori disponibili:**

/ available colors: / couleurs disponibles: / verfügbare Farben:  
Bianco Statuario, Calacatta Shine, Gray Stone,  
Lasa Aurora, Imperial Onyx

marble



# DREAMING

290/  
291



**IMPERIAL ONYX**  
60x120cm / 24"x48"  
velvet



marble





# DREAMING

292/  
293

**CALACATTA  
SHINE**  
73x73cm / 29"x29"  
lux



marble



## DREAMING

**PASSION PULPIS**  
73x73cm / 29"x29"  
lux



**ROMANCE SAFARI**  
75x75cm / 30"x30"  
velvet







marble



# DREAMING

**CRYSTAL WHITE**  
60x60cm / 24"x24"  
lux



**GRAY STONE**  
73x73cm / 29"x29"  
lux



marble



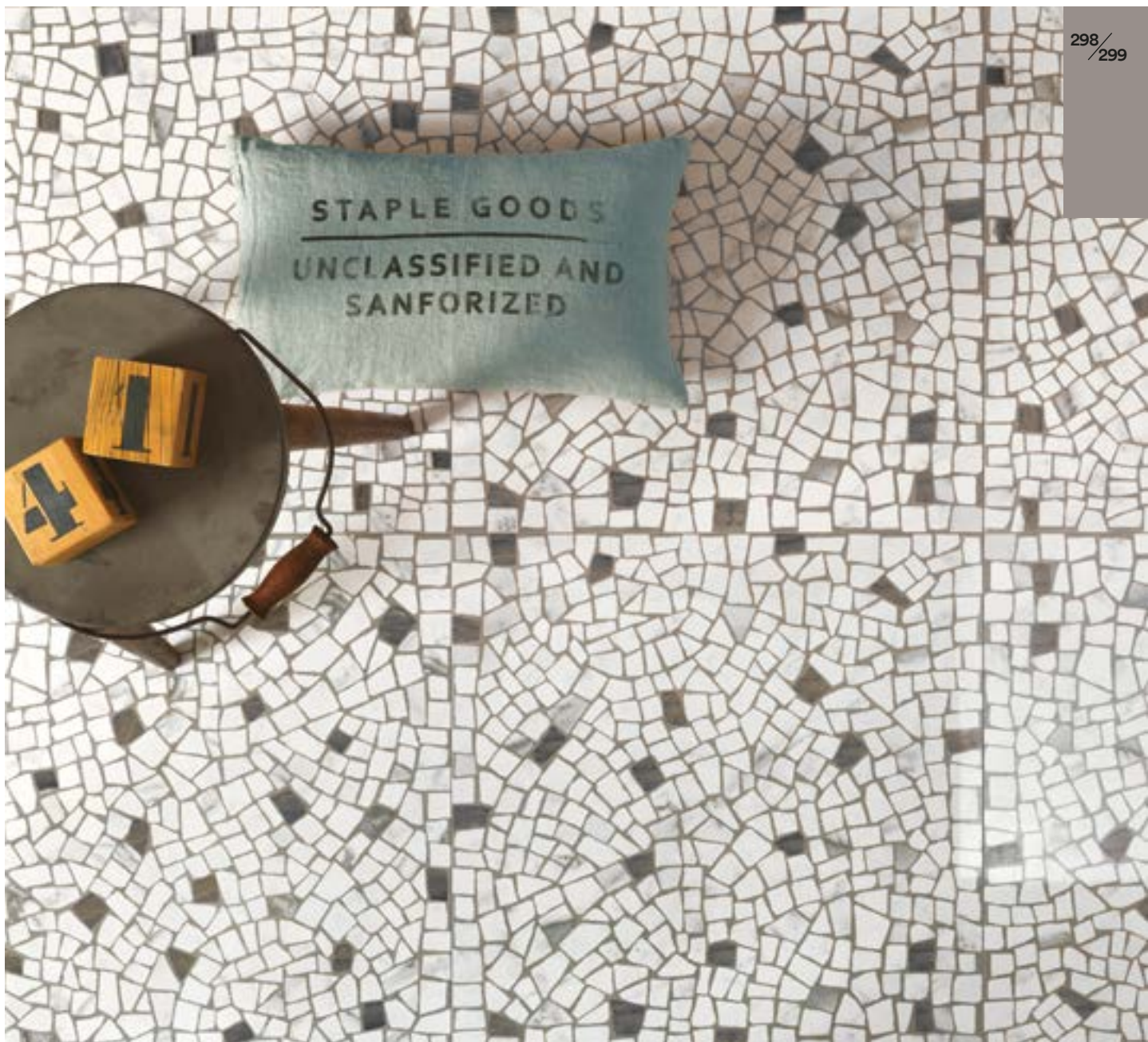

## DREAMING

### SCRAPS BIANCO

60x60cm / 24"x24"

lux



### BIANCO STATUARIO

73x73cm / 29"x29"

lux



# DREAMING

## DECORI

decors / articles / Dekore

**SCRAPS BIANCO**  
60x60cm / 24"x24"  
lux rett



**SCRAPS GRAY**  
60x60cm / 24"x24"  
lux rett

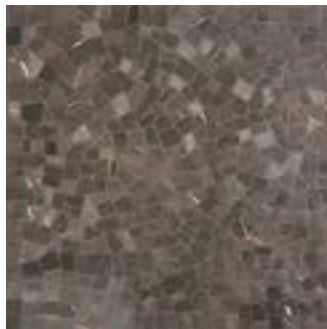

## MOSAICI

mosaics / mosaïques / Mosaik

**MOSAICO BASIC**  
imperial onyx lux  
30x30cm / 12"x12"

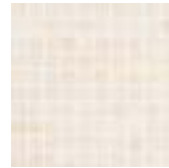

**MOSAICO BASIC**  
calacatta shine lux  
30x30cm / 12"x12"



**MOSAICO BASIC**  
gray stone lux  
30x30cm / 12"x12"

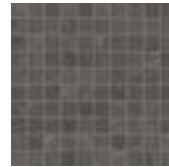

**MOSAICO BASIC**  
romance safari lux  
30x30cm / 12"x12"



**MOSAICO BASIC**  
crystal white lux  
30x30cm / 12"x12"

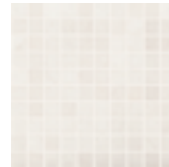

**MOSAICO BASIC**  
passion pulpis lux  
30x30cm / 12"x12"



**MOSAICO BASIC**  
lasa aurora lux  
30x30cm / 12"x12"

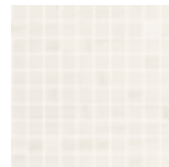

**MOSAICO BASIC**  
bianco statuario lux  
30x30cm / 12"x12"



## CALACATTA SHINE

mosaico basic  
30x30cm / 12"x12"  
lux



**PEZZI SPECIALI**

trims / pièces spéciales / Formstücke

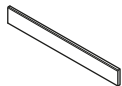
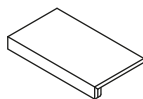
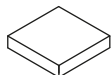
**BATTISCOPIA**  
10x60cm / 4"x24" rett**GRADINO PLUS\***  
35x60cm / 13<sup>3/4</sup>"x24" rett**ANGOLO GRADINO PLUS\***  
35x35cm / 13<sup>3/4</sup>"x13<sup>3/4</sup>" rett**RACCORDO JOLLY**  
1,3x30cm / 1/2"x12" rett**BREAK JOLLY**  
1,3x2cm / 1/2"x1/2" rett**\* Su richiesta.** / Upon request. /  
Sur demande. / auf Anfrage.**DREAMING****GRES SMALTATO A MASSA COLORATA GL**Colored-body glazed porcelain  
Grès émaillé à masse colorée  
Glasiertes Feinsteinzeug mit farbiger masse**SPESSORE**

Thickness / Epaisseur / Stärke

**10 mm** (30x60 - 60x60 - 58x116 - 60x120)**11 mm** (73x73 - 75x75)**FUGA MINIMA CONSIGLIATA**Minimum suggested joint  
Joint minimum conseillé  
Empfohlene Fugenbreite**RECT**

2 mm (INDOOR)

**NON RECT**

3-4 mm Approx (INDOOR)

**OUTDOOR**

5-6 mm Approx (\*)

(\*) Decisione a cura della Direzione Lavori Codici di Posa Nazionali  
Decision by the Construction Manager / National Laying Standards  
Décision établie par la Direction des Travaux/Codes de Pose Nationaux  
Die Entscheidung wird von der Bauleitung/gemäß nationalen Vorschriften getroffen.**STONALIZZAZIONE**

Shading / Denuançage / Spielfarbig

**ANSI A137.1****RESISTENZA ALLO SCIVOLAMENTO**Slip resistance / Résistance au glissement  
Rutschfestigkeit**ANSI A326.3**DCOF  $\geq$  0.42 (Velvet)**FINITURA LUX**Lux surface finish / Finition Lux  
Lux OberflächeConsigliato per pavimenti in ambienti residenziali.  
Recommended for flooring in residential spaces.  
Recommandé pour les sols dans des espaces résidentiels.  
Empfohlen für Fußböden in Wohnbereichen.**FINITURA VELVET**Velvet surface finish / Finition Velvet  
Velvet OberflächeConsigliato per pavimenti in ambienti residenziali e commerciale leggero.  
Recommended for flooring in residential and low-traffic commercial spaces.  
Recommandé pour les sols dans des espaces résidentiels et commerciaux (petits).  
Empfohlen für Fußböden in Wohnbereichen und für leichte gewerbliche Nutzung.**LEGENDA CODICI PRODOTTO / IMBALLI**Legend product codes / Packing  
Légende codes produits / Emballage  
Legend Produktcodes / Verpackung

pag. 400/401/402



wood



**WARM CREAM**  
20x180 cm / 8"x71"





# BIO RECOVER

 gres porcellanato | **PROTECT**  
ANTIBATTERICO - ANTIMICROBIAL

spessore / thickness **10,5mm / 12mm**

**2**

## FORMATI

sizes / formats / Formate



20x180 cm / 4<sup>3/4</sup>"x71" rett

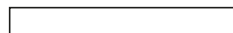

20x121,5 cm / 8"x48" nat

**3**

## COLORI

colors / couleurs / Farben

Warm Cream

Golden Flame

Old Walnut



# BIO RECOVER

**WARM CREAM**  
20x180cm / 8"x71"

frammenti white  
20x90cm / 8"x36"



304/  
305

**GOLDEN FLAME**

pie de poule white  
20x90cm / 8"x36"



wood



# BIO RECOVER

## OLD WALNUT

20x180cm / 8"x71"



306/  
307



## GOLDEN FLAME

full blue  
20x90cm / 8"x36"



# BIO RECOVER

## DECORI

decors / articles / Dekore

PIED DE POULE WHITE  
20x90cm / 8"x36"



PIED DE POULE BLUE  
20x90cm / 8"x36"



PIED DE POULE RED  
20x90cm / 8"x36"



FULL WHITE  
20x90cm / 8"x36"



FULL BLUE  
20x90cm / 8"x36"



FULL RED  
20x90cm / 8"x36"



FRAMMENTI WHITE

4x20cm / 1<sup>9</sup>/<sub>16</sub>"x8"  
8x20cm / 3<sup>1</sup>/<sub>8</sub>"x8"  
12x20cm / 4<sup>3</sup>/<sub>4</sub>"x8"



FRAMMENTI BLUE

4x20cm / 1<sup>9</sup>/<sub>16</sub>"x8"  
8x20cm / 3<sup>1</sup>/<sub>8</sub>"x8"  
12x20cm / 4<sup>3</sup>/<sub>4</sub>"x8"



FRAMMENTI RED

4x20cm / 1<sup>9</sup>/<sub>16</sub>"x8"  
8x20cm / 3<sup>1</sup>/<sub>8</sub>"x8"  
12x20cm / 4<sup>3</sup>/<sub>4</sub>"x8"



**PEZZI SPECIALI**

trims / pièces spéciales / Formstücke

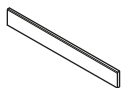
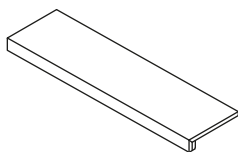
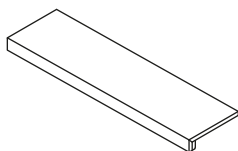
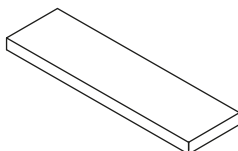
**BATTISCOPA**  
10x60cm / 4"x24" rett**GRADINO PLUS\***  
35x120cm / 13<sup>3/4</sup>"x48" rett**ANGOLO DX GRADINO PLUS\***  
35x120cm / 13<sup>3/4</sup>"x48" rett**ANGOLO SX GRADINO PLUS\***  
35x120cm / 13<sup>3/4</sup>"x48" rett**GOLDEN FLAME**

20x180cm / 8"x71"

\* **Su richiesta.** / Upon request. /  
Sur demande. / auf Anfrage.**BIO RECOVER****GRES TUTTA MASSA UGL**Full-body porcelain / Grès Cérame pleine masse /  
Vollgemischtes Durchgefärbtes Feinsteinzeug**SPESSORE**

Thickness / Epaisseur / Stärke

**10,5 mm** (20x121,5)**12 mm** (20x180)**FUGA MINIMA CONSIGLIATA**

Minimum suggested joint

Joint minimum conseillé

Empfohlene Fugenbreite

**RECT**

2 mm (INDOOR)

**NON RECT**

3-4 mm Approx (INDOOR)

**OUTDOOR**

5-6 mm Approx (\*)

(\*) Decisione a cura della Direzione Lavori Codici di Posa Nazionali  
Decision by the Construction Manager / National Laying Standards  
Décision établie par la Direction des Travaux/Codes de Pose Nationaux  
Die Entscheidung wird von der Bauleitung/gemäß nationalen Vorschriften getroffen.**STONALIZZAZIONE**

Shading / Denuançage / Spielfarbig

**ANSI A137.1****RESISTENZA ALLO SCIVOLAMENTO**

Slip resistance / Résistance au glissement

Rutschfestigkeit

**DIN 51130**

R10

**DIN 51097**

8 (A+B)

**B.C.R. - TORTUS**

μ&gt;0,40

**ANSI A326.3**

DCOF ≥ 0.42

**LEGENDA CODICI PRODOTTO / IMBALLI**

Legend product codes / Packing

Légende codes produits / Emballage

Legend Produktcodes / Verpackung

pag. 394/395

**P R ( ) T E C T**

ANTIBATTERICO - ANTIMICROBIAL



wood



**LODGE GROVE**  
20x120 cm / 8"x48"

decoro cluster mix  
20x20 cm / 8"x8"





# BIO LUMBER

 gres porcellanato

**PROTECT**  
ANTIBATTERICO - ANTIMICROBIAL

spessore / thickness **10mm**

**2**

**FORMATI** 

sizes / formats / Formate

**4**

**COLORI**

colors / couleurs / Farben



20x120 cm / 8"x48" rett



30x120cm / 12"x48" rett

 **SYSTEM L2**

spessore / thickness **20mm**



30x120cm / 12"x48" rett  
± 20mm

Lodge Grove



Lodge Greige



Lodge Brown



Lodge Grey



wood





# BIO LUMBER

312/  
313

**LODGE GREY**  
20x120cm / 8" x48"



wood





## BIO LUMBER

**LODGE BROWN**  
30x120 cm / 12"x48"  
20x120 cm / 8"x48"



**LODGE GROVE**  
20x120cm / 8"x48"  
decoro cluster mix  
20x20cm / 8"x8"



# BIO LUMBER

## DECORI

decors / articles / Dekore

CLUSTER MIX  
lodge grove  
20x20cm / 8"x8"



BEEHIVE  
lodge grove  
20x120cm / 8"x48"



CLUSTER MIX  
lodge greige  
20x20cm / 8"x8"



CLUSTER MIX  
lodge brown  
20x20cm / 8"x8"



CLUSTER MIX  
lodge grey  
20x20cm / 8"x8"



BEEHIVE  
lodge grey  
20x120cm / 8"x48"



**PEZZI SPECIALI**

trims / pièces spéciales / Formstücke

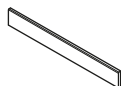
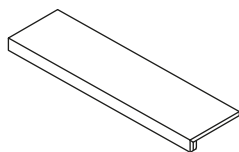
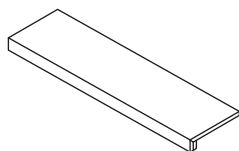
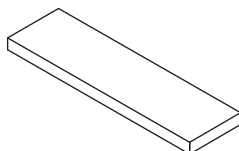
**BATTISCOPA**  
10x60cm / 4"x24" rett**GRADINO PLUS\***  
35x120cm / 13<sup>3/4</sup>"x48" rett**ANGOLO DX GRADINO PLUS\***  
35x120cm / 13<sup>3/4</sup>"x48" rett**ANGOLO SX GRADINO PLUS\***  
35x120cm / 13<sup>3/4</sup>"x48" rett**LODGE GREIGE**

20x120cm / 8"x48"

cluster mix lodge greige  
20x20cm / 8"x8"\* Su richiesta. / Upon request. /  
Sur demande. / auf Anfrage.**BIO LUMBER****GRES TUTTA MASSA UGL**Full-body porcelain / Grès Cérame pleine masse  
Vollgemischtes Durchgefärbtes Feinsteinzeug**SPESSORE**

Thickness / Epaisseur / Stärke

**10 mm****20 mm (30x120)****FUGA MINIMA CONSIGLIATA**

Minimum suggested joint

Joint minimum conseillé

Empfohlene Fugenbreite

**RECT**

2 mm (INDOOR)

**NON RECT**

3-4 mm Approx (INDOOR)

**OUTDOOR**

5-6 mm Approx (\*)

(\*) Decisione a cura della Direzione Lavori Codici di Posa Nazionali  
Decision by the Construction Manager / National Laying Standards  
Décision établie par la Direction des Travaux/Codes de Pose Nationaux  
Die Entscheidung wird von der Bauleitung/gemäß nationalen Vorschriften getroffen.**STONALIZZAZIONE**

Shading / Denuançage / Spielfarbig

**ANSI A137.1****RESISTENZA ALLO SCIVOLAMENTO**

Slip resistance / Résistance au glissement

Rutschfestigkeit

**DIN 51130**

R10

**DIN 51097**

B (A+B)

**B.C.R. - TORTUS** $\mu > 0,40$ **ANSI A326.3**DCOF  $\geq 0.42$ **AS 4586:2013**

P3

**BS 7976:2002**

PTV 36+Wet (Slider 96)

**LEGENDA CODICI PRODOTTO / IMBALLI**

Legend product codes / Packing

Légende codes produits / Emballage

Legend Produktcodes / Verpackung

pag. 393

**P R ( ) T E C T**

ANTIBATTERICO - ANTIMICROBIAL



wood



**OAK PATINATO  
CHIARO**  
20x120 cm / 8"x48"

strip  
20x120cm / 8"x48"





# BIO TIMBER

 gres porcellanato

**P R ( ) T E C T**  
ANTIBATTERICO - ANTIMICROBIAL

spessore / thickness **11mm**

**1**

**FORMATO** <sup>RT<sup>1</sup></sup>  
size / format / Format

**4**

**COLORI**  
colors / couleurs / Farben



20x120 cm / 8"x48" rett

Oak Patinato Chiaro



Oak Provenzale



Oak Patinato Scuro



Oak Grigio

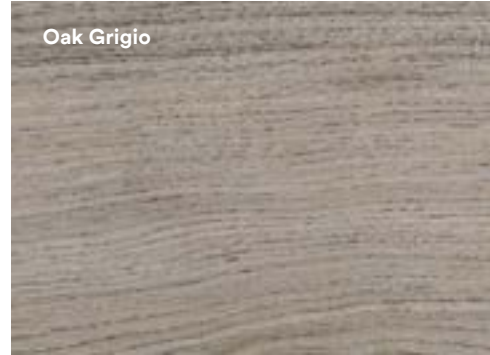

wood



## BIO TIMBER

**OAK PROVENZALE**  
20x120cm / 8"x48"





**OAK PATINATO SCURO**  
20x120cm / 8"x48"



stone

## BIO TIMBER

**OAK GRIGIO**  
20x120cm / 8"x48"





# BIO TIMBER

## DECORI

decors / articles / Dekore

COMPASS  
oak patinato chiaro  
20x120cm / 8"x48"



COMPASS  
oak patinato scuro  
20x120cm / 8"x48"



COMPASS  
oak provenzale  
20x120cm / 8"x48"



COMPASS  
oak grigio  
20x120cm / 8"x48"



TRIANGLES  
oak patinato chiaro  
20x120cm / 8"x48"



TRIANGLES  
oak patinato scuro  
20x120cm / 8"x48"



STRIP  
oak patinato chiaro  
20x120cm / 8"x48"



STRIP  
oak patinato scuro  
20x120cm / 8"x48"



STRIP  
oak provenzale  
20x120cm / 8"x48"



STRIP  
oak grigio  
20x120cm / 8"x48"



TRIANGLES  
oak provenzale  
20x120cm / 8"x48"



TRIANGLES  
oak grigio  
20x120cm / 8"x48"



**PEZZI SPECIALI**

trims / pièces spéciales / Formstücke

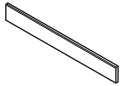
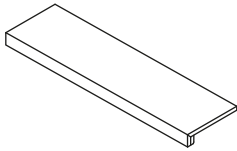
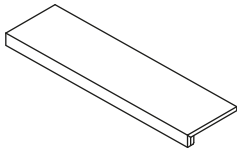
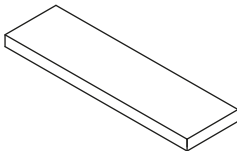
**BATTISCOPIA**  
10x60cm / 4"x24" rett**GRADINO PLUS\***  
35x120cm / 13<sup>3/4</sup>"x48" rett**ANGOLO DX GRADINO PLUS\***  
35x120cm / 13<sup>3/4</sup>"x48" rett**ANGOLO SX GRADINO PLUS\***  
35x120cm / 13<sup>3/4</sup>"x48" rett\* Su richiesta. / Upon request. /  
Sur demande. / auf Anfrage.**BIO TIMBER****GRES TUTTA MASSA UGL**Full-body porcelain / Grès Cérame pleine masse /  
Vollgemischtes Durchgefärbtes Feinsteinzeug**SPESSORE**

Thickness / Epaisseur / Stärke

**11 mm****FUGA MINIMA CONSIGLIATA**Minimum suggested joint  
Joint minimum conseillé  
Empfohlene Fugenbreite**RECT**

2 mm (INDOOR)

**NON RECT**

3-4 mm Approx (INDOOR)

**OUTDOOR**

5-6 mm Approx (\*)

(\*) Decisione a cura della Direzione Lavori Codici di Posa Nazionali  
Decision by the Construction Manager / National Laying Standards  
Décision établie par la Direction des Travaux/Codes de Pose Nationaux  
Die Entscheidung wird von der Bauleitung/gemäß nationalen Vorschriften getroffen.**STONALIZZAZIONE**

Shading / Denuançage / Spielfarbig

**ANSI A137.1****RESISTENZA ALLO SCIVOLAMENTO**Slip resistance / Résistance au glissement  
Rutschfestigkeit**DIN 51130****R9****B.C.R. - TORTUS** $\mu > 0,40$ **ANSI A326.3****DCOF  $\geq$  0.42****LEGENDA CODICI PRODOTTO / IMBALLI**Legend product codes / Packing  
Légende codes produits / Emballage  
Legend Produktcodes / Verpackung**pag. 395/396****P R O T E C T**

ANTIBATTERICO - ANTIMICROBIAL

wood



**OAK NOISETTE**  
20x120 cm / 8"x48"





# BIO PLANK

 gres porcellanato

**P R ( ) T E C T**  
ANTIBATTERICO - ANTIMICROBIAL

spessore / thickness **11mm**

**1**

**FORMATO** <sup>RT<sup>1</sup></sup>  
size / format / Format

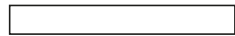

20x120 cm / 8"x48" rett

**2**

**COLORI**  
colors / couleurs / Farben

Oak Ice

Oak Noisette

# BIO PLANK



**DECORI**

decors / articles / Dekore

**DECORO FENCE**  
oak ice  
20x120cm / 8"x48"



**DECORO FENCE**  
oak noisette  
20x120cm / 8"x48"

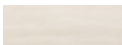

**OAK ICE**  
20x120cm / 8"x48"

**PEZZI SPECIALI**

trims / pièces spéciales / Formstücke

**BATTISCOPA**  
10x60cm / 4"x24" rett

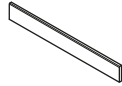

**GRADINO PLUS\***  
35x120cm / 13<sup>3/4</sup>"x48" rett

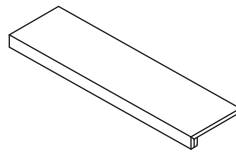

**ANGOLO DX GRADINO PLUS\***  
35x120cm / 13<sup>3/4</sup>"x48" rett

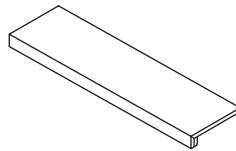

**ANGOLO SX GRADINO PLUS\***  
35x120cm / 13<sup>3/4</sup>"x48" rett

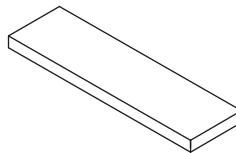

\* Su richiesta. / Upon request. /  
Sur demande. / auf Anfrage.

**BIO PLANK****GRES TUTTA MASSA UGL**

Full-body porcelain / Grès Cérame pleine masse /  
Vollgemischtes Durchgefärbtes Feinsteinzeug

**SPESSORE**

Thickness / Epaisseur / Stärke

**11 mm****FUGA MINIMA CONSIGLIATA**

Minimum suggested joint  
Joint minimum conseillé  
Empfohlene Fugenbreite

**RECT**

2 mm (INDOOR)

**NON RECT**

3-4 mm Approx (INDOOR)

**OUTDOOR**

5-6 mm Approx (\*)

(\*) Decisione a cura della Direzione Lavori Codici di Posa Nazionali  
Decision by the Construction Manager / National Laying Standards  
Décision établie par la Direction des Travaux/Codes de Pose Nationaux  
Die Entscheidung wird von der Bauleitung/gemäß nationalen Vorschriften getroffen.

**STONALIZZAZIONE**

Shading / Denuançage / Spielfarbig

**ANSI A137.1****RESISTENZA ALLO SCIVOLAMENTO**

Slip resistance / Résistance au glissement  
Rutschfestigkeit

**DIN 51130****R9****B.C.R. - TORTUS** $\mu > 0,40$ **ANSI A326.3**DCOF  $\geq 0.42$ **BS 7976:2002**

PTV 36+Wet (Dry)

PTV 25-35 (Wet)

**BRITISH PENDULUM TEST BS 7976:2002****4S (SLIDER 96)**

Dry: low slip potential PTV 36+

Wet: moderate slip potential PTV 25-35

**LEGENDA CODICI PRODOTTO / IMBALLI**

Legend product codes / Packing  
Légende codes produits / Emballage  
Legend Produktcodes / Verpackung

**pag. 394****PROTECT**

ANTIBATTERICO - ANTIMICROBIAL

**CITY**  
design  
Diego Grandi

**MOSCOVA**  
**ANTRACITE 3D**  
30x60cm / 12"x24"



LEA CERAMICHE

# CITY

design Diego Grandi

 gres porcellanato

spessore / thickness **11mm**

**1**

**FORMATO**  $\text{RT}^1$

size / format / Format

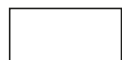

30x60cm / 12"x24" rett

**2**

**COLORI**

colors / couleurs / Farben



330/  
331

Moscova antracite 3D



Cordusio bronze 3D

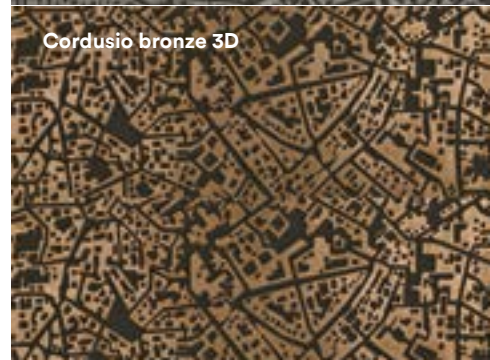



# CITY

**CORDUSIO BRONZE 3D**  
30x60cm / 12"x24"



## CITY

---

### **GRES SMALTATO A MASSA COLORATA GL**

Colored-body glazed porcelain  
Grès émaillé a masse colorée  
Glasiertes Feinsteinzeug mit farbiger masse

---

### **SPESSORE**

Thickness / Epaisseur / Stärke

**11 mm**

---

### **FUGA MINIMA CONSIGLIATA**

Minimum suggested joint  
Joint minimum conseillé  
Empfohlene Fugenbreite

#### **RECT**

2 mm (INDOOR)

#### **NON RECT**

3-4 mm Approx (INDOOR)

#### **OUTDOOR**

5-6 mm Approx (\*)

(\*) Decisione a cura della Direzione Lavori Codici di Posa Nazionali  
Decision by the Construction Manager / National Laying Standards  
Décision établie par la Direction des Travaux/Codes de Pose Nationaux  
Die Entscheidung wird von der Bauleitung/gemäß nationalen Vorschriften getroffen.

---



### **LEGENDA CODICI PRODOTTO / IMBALLI**

Legend product codes / Packing  
Légende codes produits / Emballage  
Legend Produktcodes / Verpackung

**pag. 396**

---

**GOCCIA**  
design  
Kravitz Design Inc.



**WHITE**  
single tuft out matt  
10x40cm / 4"x16"

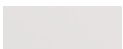



# GOCCIA

design Kravitz Design Inc.

monoporosa

spessore / thickness **9mm**

## 2

### FORMATI

sizes / formats / Formate



13x13cm / 5<sup>1</sup>/<sub>8</sub>"x5<sup>1</sup>/<sub>8</sub>" nat



10x40cm / 4"x16" nat

## 2

### FINITURE

finishes / surfaces / Oberfläche

**GLOSSY**

**MATT**

## 2

### COLORI

colors / couleurs / Farben

White

Black



## GOCCIA

### WHITE

tune in glossy  
13x13cm / 5<sup>1</sup>/<sub>8</sub>" x 5<sup>1</sup>/<sub>8</sub>"

tune out glossy  
13x13cm / 5<sup>1</sup>/<sub>8</sub>" x 5<sup>1</sup>/<sub>8</sub>"

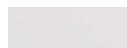

**BLACK**  
distorsion glossy  
13x13cm / 5<sup>1</sup>/<sub>8</sub>" x 5<sup>1</sup>/<sub>8</sub>"







# GOCCIA

## FORMATI E COLORI

sizes and colors / formats et couleurs / Formaten und Farben

### WHITE

SINGLE TUNE IN  
white glossy  
10x40cm / 4"x16"



SINGLE TUNE OUT  
white glossy  
10x40cm / 4"x16"



SINGLE TUNE IN  
white matt  
10x40cm / 4"x16"



SINGLE TUNE OUT  
white matt  
10x40cm / 4"x16"



DOUBLE TUNE IN  
white gloss  
10x40cm / 4"x16"



DOUBLE TUNE OUT  
white gloss  
10x40cm / 4"x16"



DOUBLE TUNE IN  
white matt  
10x40cm / 4"x16"



DOUBLE TUNE OUT  
white matt  
10x40cm / 4"x16"



TUNE IN  
white glossy  
13x13cm / 5<sup>1</sup>/<sub>8</sub>"x5<sup>1</sup>/<sub>8</sub>"



TUNE IN  
white matt  
13x13cm / 5<sup>1</sup>/<sub>8</sub>"x5<sup>1</sup>/<sub>8</sub>"



TUNE OUT  
white glossy  
13x13cm / 5<sup>1</sup>/<sub>8</sub>"x5<sup>1</sup>/<sub>8</sub>"



TUNE OUT  
white matt  
13x13cm / 5<sup>1</sup>/<sub>8</sub>"x5<sup>1</sup>/<sub>8</sub>"



DISTORSION  
white glossy  
13x13cm / 5<sup>1</sup>/<sub>8</sub>"x5<sup>1</sup>/<sub>8</sub>"



**FORMATI E COLORI**

sizes and colors / formats et couleurs / Formaten und Farben

**BLACK**

SINGLE TUNE IN  
black glossy  
10x40cm / 4"x16"



SINGLE TUNE OUT  
black glossy  
10x40cm / 4"x16"



SINGLE TUNE IN  
black matt  
10x40cm / 4"x16"



SINGLE TUNE OUT  
black matt  
10x40cm / 4"x16"



DOUBLE TUNE IN  
black gloss  
10x40cm / 4"x16"



DOUBLE TUNE OUT  
black gloss  
10x40cm / 4"x16"



DOUBLE TUNE IN  
black matt  
10x40cm / 4"x16"



DOUBLE TUNE OUT  
black matt  
10x40cm / 4"x16"



TUNE IN  
black glossy  
13x13cm / 5<sup>1</sup>/<sub>8</sub>"x5<sup>1</sup>/<sub>8</sub>"



TUNE IN  
black matt  
13x13cm / 5<sup>1</sup>/<sub>8</sub>"x5<sup>1</sup>/<sub>8</sub>"



TUNE OUT  
black glossy  
13x13cm / 5<sup>1</sup>/<sub>8</sub>"x5<sup>1</sup>/<sub>8</sub>"



TUNE OUT  
black matt  
13x13cm / 5<sup>1</sup>/<sub>8</sub>"x5<sup>1</sup>/<sub>8</sub>"



DISTORSION  
black glossy  
13x13cm / 5<sup>1</sup>/<sub>8</sub>"x5<sup>1</sup>/<sub>8</sub>"



# GOCCIA

shapes & colors



**GOCCIA È ABBINABILE ALLA SERIE PROGETTO L14**

Goccia can be matched with Progetto L14 / Goccia s'accorde à la collection Progetto L14  
Goccia passend zu serie Progetto L14

MOOD 14  
xwhite glossy  
10x40cm / 4"x16"

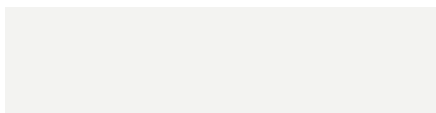

MOOD 14  
xblack glossy  
10x40cm / 4"x16"

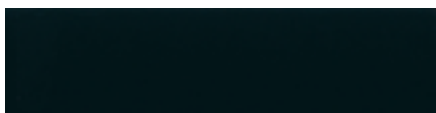

MOOD 14  
gesso matt  
10x40cm / 4"x16"

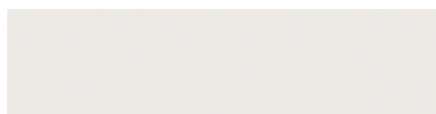
**WHITE**

single tune in glossy  
10x40cm / 4"x16"

single tune out glossy  
10x40cm / 4"x16"

**PROGETTO L14****XWHITE**

glossy mood 14  
10x40cm / 4"x16"

**GOCCIA****MONOPOROSA IN PASTA BIANCA  
SMALTATA GL**

Glazed white-body porous single-fired tiles / Mono-  
cuissons en pâte blanche émaillé / Weißscherbige  
monoporosa

**SPESSORE**

Thickness / Epaisseur / Stärke

9 mm

**FUGA MINIMA CONSIGLIATA**

Minimum suggested joint  
Joint minimum conseillé  
Empfohlene Fugenbreite

**RECT**

2 mm (INDOOR)

**NON RECT**

3-4 mm Approx (INDOOR)

**OUTDOOR**

5-6 mm Approx (\*)

(\*) Decisione a cura della Direzione Lavori Codici di Posa Nazionali  
Decision by the Construction Manager / National Laying Standards  
Décision établie par la Direction des Travaux/Codes de Pose Nationaux  
Die Entscheidung wird von der Bauleitung/gemäß nationalen Vorschriften getroffen.

**STONALIZZAZIONE**

Shading / Denuançage / Spielfarbig

ANSI A137.1

**LEGENDA CODICI PRODOTTO / IMBALLI**

Legend product codes / Packing  
Légende codes produits / Emballage  
Legend Produktcodes / Verpackung

pag. 402

**NERO**

Bolli sfalsati

Curva mista

Curva diagonale  
30x30cm / 12"x12"





# LINK

## PERCORSI TATTILI

project for the visually-impaired or blind / série plaque tactiles pour mal voyant / programm für blinde leute

 gres porcellanato

spessore / thickness **9mm**

## 2

### FORMATI

sizes / formats / Formate



20x20cm / 8"x8" nat



30x30 cm / 12"x12" nat

## 3

### COLORI

colors / couleurs / Farben

Bianco

Nero

Giallo

## FORMATI E COLORI

sizes and colors / formats et couleurs / Formaten und Farben

**BOLLI SFALSATI**  
bianco  
30x30cm / 12"x12"



**BOLLI SFALSATI**  
nero  
30x30cm / 12"x12"

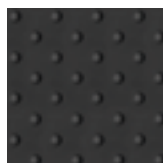

**BOLLI SFALSATI**  
giallo  
30x30cm / 12"x12"



**CURVA MISTA**  
bianco  
30x30cm / 12"x12"



**CURVA MISTA**  
nero  
30x30cm / 12"x12"

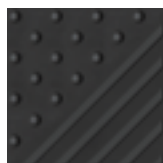

**CURVA MISTA**  
giallo  
30x30cm / 12"x12"



**CURVA DIAGONALE**  
bianco  
30x30cm / 12"x12"

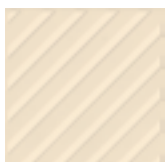

**CURVA DIAGONALE**  
nero  
30x30cm / 12"x12"

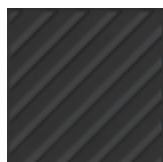

**CURVA DIAGONALE**  
giallo  
30x30cm / 12"x12"

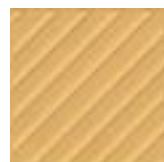

**RETTILINEO**  
bianco  
30x30cm / 12"x12"

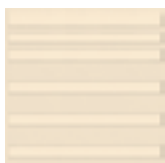

**RETTILINEO**  
nero  
30x30cm / 12"x12"

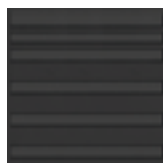

**RETTILINEO**  
giallo  
30x30cm / 12"x12"



### Sezioni

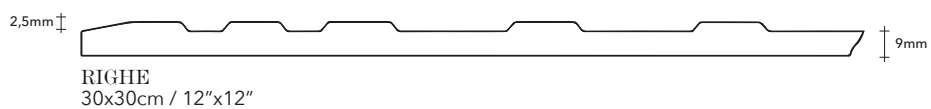
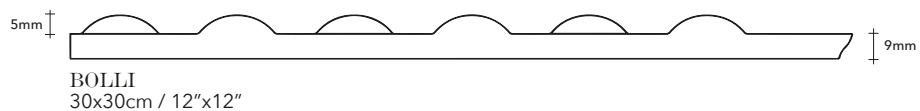

## LINK

## GRES TUTTA MASSA UGL

Full-body porcelain / Grès Cérame pleine masse /  
Vollgemischtes Durchgefärbtes Feinsteinzeug /

## SPESSORE

Thickness / Epaisseur / Stärke

9 mm

## FUGA MINIMA CONSIGLIATA

Minimum suggested joint  
Joint minimum conseillé  
Empfohlene Fugenbreite

## RECT

2 mm (INDOOR)

## NON RECT

3-4 mm Approx (INDOOR)

## OUTDOOR

5-6 mm Approx (\*)

(\*) Decisione a cura della Direzione Lavori Codici di Posa Nazionali  
Decision by the Construction Manager / National Laying Standards  
Décision établie par la Direction des Travaux/Codes de Pose Nationaux  
Die Entscheidung wird von der Bauleitung/gemäß nationalen Vorschriften getroffen.



## STONALIZZAZIONE

Shading / Denuançage / Spielfarbig

ANSI A137.1

## LEGENDA CODICI PRODOTTO / IMBALLI

Legend product codes / Packing  
Légende codes produits / Emballage  
Legend Produktcodes / Verpackung

pag. 403

BOLLI SFALSATI 13  
bianco  
20x20cm / 8"x8"



BOLLI SFALSATI 13  
nero  
20x20cm / 8"x8"



BOLLI SFALSATI 13  
giallo  
20x20cm / 8"x8"



BOLLI SFALSATI 12  
bianco  
20x20cm / 8"x8"



BOLLI SFALSATI 12  
nero  
20x20cm / 8"x8"



BOLLI SFALSATI 12  
giallo  
20x20cm / 8"x8"



RIGHE  
bianco  
20x20cm / 8"x8"

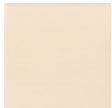

RIGHE  
nero  
20x20cm / 8"x8"

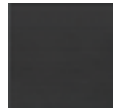

RIGHE  
giallo  
20x20cm / 8"x8"



BORCHIE  
bianco  
20x20cm / 8"x8"



BORCHIE  
nero  
20x20cm / 8"x8"



BORCHIE  
giallo  
20x20cm / 8"x8"



## Sezioni

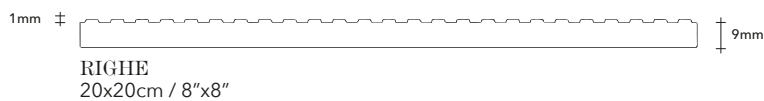
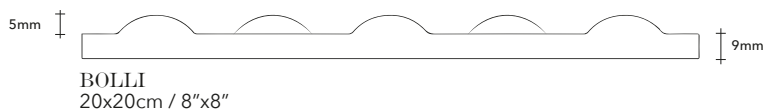



**LIME L2**  
60x60cm / 24"x24"



**CENDRE L2**  
60x60cm / 24"x24"



# SYSTEM L2

 SYSTEM L2

spessore / thickness **20mm**

**4**

**FORMATI**

sizes / formats / Formate

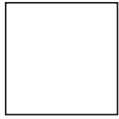

60x60cm / 24"x24" rett  
± 20mm  
grip



45x90cm / 18"x36" rett  
± 20mm  
grip



30x120cm / 12"x48" rett  
± 20mm  
grip



60x120cm / 24"x48" rett  
± 20mm  
grip

**18**

**COLORI**

colors / couleurs / Farben

**NEXTONE**

**WATERFALL**

**CLIFFSTONE**

**BIO LUMBER**

**STONECLAY**

	<p><b>Next white</b></p>  <p>60x120cm 60x60cm</p>	<p><b>Ivory Flow L2</b></p>  <p>45x90cm 60x60cm</p>	<p><b>White Dover L2</b></p>  <p>60x60cm</p>	<p><b>Lodge Grove L2</b></p>  <p>30x120cm</p>
	<p><b>Next gray</b></p>  <p>60x120cm 60x60cm</p>	<p><b>Silver Flow L2</b></p>  <p>45x90cm 60x60cm</p>	<p><b>Beige Madeira L2</b></p>  <p>60x60cm</p>	<p><b>Lodge Greige L2</b></p>  <p>30x120cm</p>
<p><b>Lime L2</b></p>  <p>60x60cm</p>	<p><b>Next taupe</b></p>  <p>60x120cm 60x60cm</p>	<p><b>Gray Flow L2</b></p>  <p>45x90cm 60x60cm</p>	<p><b>Taupe Moher L2</b></p>  <p>60x60cm</p>	<p><b>Lodge Brown L2</b></p>  <p>30x120cm</p>
<p><b>Cendre L2</b></p>  <p>60x60cm</p>	<p><b>Next dark</b></p>  <p>60x120cm 60x60cm</p>	<p><b>Dark Flow L2</b></p>  <p>45x90cm 60x60cm</p>	<p><b>Grey Tenerife L2</b></p>  <p>60x60cm</p>	<p><b>Lodge Grey L2</b></p>  <p>30x120cm</p>





## SYSTEM L2

**IVORY FLOW L2**  
45x90 cm / 18"x36"

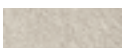

**NEXT TAUPE L2**  
60x120cm / 24"x48"



**NEXT DARK L2**  
60x60cm / 24"x24"



# SYSTEM L2

**LODGE BROWN L2**  
30x120 cm / 12"x48"





**PEZZI SPECIALI**

trims / pièces spéciales / Formstücke

**NEXTONE / BIO LUMBER  
STONECLAY / CLIFFSTONE****GRIGLIA\***

15x60cm / 6"x24" rett

**GRIGLIA ANGOLARE DX\***

15x60cm / 6"x24" rett

**GRADINO ANGOLARE SX\***

15x60cm / 6"x24" rett

**COSTA TORO\***

30x60cm / 12"x24" rett

**COSTA TORO ANGOLARE DX\***

30x60cm / 12"x24" rett

**COSTA TORO ANGOLARE SX\***

30x60cm / 12"x24" rett

**COSTA RETTA\***

30x60cm / 12"x24" rett

**COSTA RETTA ANGOLARE DX\***

30x60cm / 12"x24" rett

**COSTA RETTA ANGOLARE SX\***

30x60cm / 12"x24" rett

**COSTA TORO STEP\***

30x60cm / 12"x24" rett

**COSTA RETTA STEP\***

30x60cm / 12"x24" rett

**COSTA TORO CON GOCCIOLATOIO\***

30x60cm / 12"x24" rett

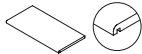
**COSTA RETTA CON GOCCIOLATOIO\***

30x60cm / 12"x24" rett

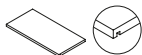
**WATERFALL****GRIGLIA\***

15x45cm / 6"x18" rett

**GRIGLIA ANGOLARE DX\***

15x45cm / 6"x18" rett

**GRADINO ANGOLARE SX\***

15x45cm / 6"x18" rett

**COSTA TORO\***

30x90cm / 12"x36" rett

**COSTA TORO ANGOLARE DX\***

30x90cm / 12"x36" rett

**COSTA TORO ANGOLARE SX\***

30x90cm / 12"x36" rett

**COSTA RETTA\***

30x90cm / 12"x36" rett

**COSTA RETTA ANGOLARE DX\***

30x90cm / 12"x36" rett

**COSTA RETTA ANGOLARE SX\***

30x90cm / 12"x36" rett

**COSTA TORO STEP\***

30x90cm / 12"x36" rett

**COSTA RETTA STEP\***

30x90cm / 12"x36" rett

**SYSTEM L2****GRES TUTTA MASSA UGL**Full-body porcelain / Grès Cérame pleine masse  
Vollgemischtes Durchgefärbtes Feinsteinzeug**SPESSORE**Thickness / Epaisseur / Stärke  
**20 mm****INFORMAZIONI PER LA POSA**Information for laying / Informations pour la pose  
Informationen zur Verlegung**Consultare il manuale "Soluzioni applicative prodotti 20mm"** / Consult the manual "applicable solutions 20mm products" / Consultez le manuel « solutions applicables produits 20 mm » / Siehe Handbuch "Anwendungslösungen für 20 mm-Produkte"**V2****STONALIZZAZIONE**Shading / Denuançage / Spielfarbig  
(White Dover L2 - Beige Madeira L2  
Taupe Shine L2 - Grey Tenerife L2)**V3**(Ivory Flow L2 - Silver Flow L2  
Gray Flow L2 - Dark Flow L2  
Lime L2 - Cendre L2  
Next White L2 Next Gray L2  
Next Taupe L2 - Next Dark L2)**V4**(Lodge Grove L2 - Lodge Greige L2  
Lodge Brown L2 - Lodge Grey L2)**ANSI A137.1****RESISTENZA ALLO SCIVOLAMENTO**Slip resistance / Résistance au glissement  
Rutschfestigkeit**DIN 51130**

R11

**DIN 51097**

C (A+B+C)

**B.C.R. - TORTUS** $\mu > 0,40$ **ANSI A326.3**DCOF  $\geq 0.42$ **AS 4586:2013**

P4

**LEGENDA CODICI PRODOTTO / IMBALLI**Legend product codes / Packing  
Légende codes produits / Emballage  
Legend Produktcodes / Verpackung

pag. 410/411/412

\* Su richiesta. Per maggiori informazioni circa quantità minime e tempi di consegna rivolgersi all'ufficio commerciale. / Upon request. For more information about minimum quantities and delivery times please contact the sales department. / Sur demande. Pour plus d'informations sur les quantités minimales et délais de livraison s'il vous plaît contacter le département des ventes. / auf Anfrage. Für weitere Infos über die Mindestmengen und Lieferzeiten wenden Sie sich bitte an unserer Verkaufsabteilung.



354

## legenda tecnica

TECHNICAL NOTICE - LÉGENDE TECHNIQUE  
ERLÄUTERUNG DER TECHNISCHEN BEGRIFFE

356

## lea e l'ambiente

LEA AND THE ENVIRONMENT - LEA ET L'ENVIRONNEMENT  
LEA UND UMWELT

358

## certificazioni

CERTIFICATES - LES CERTIFICATS - ZERTIFIKATE

362

## caratteristiche tecniche

TECHNICAL SPECIFICATION - CARACTÉRISTIQUES TECHNIQUES  
TECHNISCHE MERKMALE

371

## manuali tecnici

TECHNICAL MANUALS - MANUELS TECHNIQUES  
TECHNISCHE HANDBÜCHER

372

## pulizia e manutenzione

CLEANING AND MAINTENANCE - NETTOYAGE ET L'ENTRETIEN  
REINIGUNG UND PFLEGE

381

## codici prodotto e imballi

PRODUCT CODES AND PACKING - CODES PRODUITS ET EMBALLAGE  
PRODUKTCODES UND VERPACKUNG

419

## condizioni generali di vendita

GENERAL SALES CONDITIONS - CONDITIONS GENERALES DE VENTE  
ALLGEMEINE VERKAUFSKONDITIONEN

423

## disclaimer

TECHNICAL INFO

352/  
353

# LEGENDA TECNICA

## TECHNICAL NOTICE

## LÉGENDE TECHNIQUE

## ERLÄUTERUNG DER TECHNISCHEN BEGRIFFE

### ● SUPPORTO

**GRES TUTTA MASSA UGL**  
prodotto che mostra in superficie esattamente i colori che attraversano tutto il corpo della piastrella.

**GRES SMALTATO A MASSA COLORATA GL**  
prodotto colorato negli impasti del corpo della piastrella ulteriormente arricchito da applicazioni di smaltatura sulla superficie.

**MONOPOROSA IN PASTA BIANCA SMALTATA GL**  
prodotto destinato al rivestimento con impasto poroso di colore biancastro, monocalibro, smaltato e colorato solo in superficie.

**GRES SMALTATO GL**  
prodotto in gres porcellanato monocoloro di base che viene colorato in superficie esclusivamente attraverso lo smalto.

**GRES LAMINATO UGL**  
prodotto in gres porcellanato tutta massa frutto di una tecnologia innovativa di compattazione, dotato di caratteristiche uniche di dimensioni, spessore, leggerezza, resistenza e flessibilità.

**DOPPIA PRESSATURA**  
processo produttivo che miscela i differenti colori degli impasti del corpo piastrella in una prima pressatura e compatta i colori delle applicazioni successive attraverso una seconda ulteriore pressatura.

### ● BORDO

**NATURALE (nat)**  
bordo derivato esclusivamente dalla formatura della pressa.

**RETTIFICATO (rett)**  
bordo perfettamente rettilineo (a volte accompagnato da un lieve bisello sul perimetro di superficie) derivante da lavorazione di squadratura che riporta i pezzi ad un'unica dimensione dei lati, indipendentemente dai lotti produttivi.

### ● GRADO DI STONALIZZAZIONE

indica la differenza di tono delle singole piastrelle come non omogenee tra di loro.  
V0 aspetto molto uniforme - V1 aspetto uniforme  
V2 variazioni minime - V3 variazioni moderate  
V4 variazioni sostanziali

### ● FINITURA DI SUPERFICIE

**ANTICATA - NATURALE (nat)**  
**TEXTURE (txt) - VELVET:**  
superficie che non viene in alcun modo lavorata dopo la cottura.

**LUX:**  
finitura superficiale lucida, ottenuta tramite leggera abrasione meccanica della superficie.

**LEVIGATA (lev):**  
finitura superficiale lucida, ottenuta asportando un piccolo strato di materiale in modo da evidenziare le caratteristiche estetiche del supporto.

**LAPPATA (lapp):**  
superficie resa più scorrevole e lucente attraverso una lavorazione meccanica dopo la cottura.

**GRIP - TEXTURE GRIP:**  
superficie caratterizzata da un'elevata resistenza allo scivolamento, che la rende adatta anche per applicazioni in esterno.

### ● FUGA

distanza consigliata tra le piastrelle.

### ● BASE

**FULL-BODY PORCELAIN UGL**  
a product which has the same colours on the surface that pass through the body of the tile.

**COLOURED BODY GLAZED PORCELAIN GL**  
a product which has a coloured body, further enhanced by glazed surface applications.

**AZED WHITE-BODY POROUS SINGLE-FIRED TILES**  
a product designed for wall tiles with porous whitish body, single work-size, glazed and coloured only on the surface.

**GLAZED PORCELAIN GL**  
a product in glazed, plain colour base stoneware, coloured on the surface exclusively through the glaze.

**LAMINATED PORCELAIN UGL**  
full body porcelain produced using an innovative compacting technology, that offers unique characteristics in terms of dimension, thickness, lightness, resistance and flexibility.

**DOUBLE PRESSING**  
a production process which combines the various colours of the tile body in a first pressing and compacts the subsequent application colours by means of a second, final pressing.

### ● EDGE

**NATURALE (nat)**  
an edge produced exclusively from the moulding of the press.

**RECTIFIED (rett)**  
a perfectly straight edge (occasionally with a slight chamfer on the surface perimeter) obtained through the process of squaring, which matches the sides of the tiles perfectly, regardless of the production lot.

### ● SHADING

indicates the different shades of colour between the single, non-homogeneous tiles.  
V0 very uniform appearance - V1 uniform appearance  
V2 slight variations - V3 moderate variations  
V4 substantial variation

### ● SURFACE FINISH

**ANTICATA - NATURALE (nat)**  
**TEXTURE (txt) - VELVET:**  
a surface which is not treated in any way after firing.

**LUX:**  
shiny superficial finish, obtained through a light mechanical abrasion of the surface.

**LEVIGATA (lev):**  
polished surface finish, achieved by removing a small layer of material in order to highlight the aesthetic characteristics of the surface.

**LAPPATA (lapp):**  
a smoother, shinier surface thanks to a special mechanical process after firing.

**GRIP - TEXTURE GRIP:**  
the high coefficient of friction makes it also suitable for exterior applications.

### ● JOINT

recommended gap between tiles.

## • SUPPORT

**GRÈS PLEINE MASSE UGL**  
carreau présentant à la surface exactement les mêmes couleurs qui traversent toute sa masse.

**GRÈS ÉMAILLÉ À MASSE COLORÉE GL**  
carreau coloré dans la masse dont la surface a été ensuite enrichie par des émaillages.

**CARREAU MONOPOREUX ÉMAILLÉ À PÂTE BLANCHE GL**  
carreau à pâte poreuse de couleur blanchâtre pour le revêtement des murs, monocalibre, émaillé et coloré uniquement en surface.

**GRÈS ÉMAILLÉ GL**  
carreau en grès cérame avec base monochrome et surface colorée uniquement par l'émail.

**GRÈS LAMINÉ UGL**  
produit en grès cérame pleine masse fruit d'une technologie innovante de compactation, doté de caractéristique unique de dimensions, épaisseur, légèreté, résistance et flexibilité.

**DOUBLE PRESSAGE**  
procédé de fabrication qui mélange les différentes couleurs de la masse du carreau lors d'un premier pressage et compacte les couleurs des applications suivantes par une deuxième et dernière opération de pressage.

## • BORD

**NATURALE (nat)**  
bord dont la forme n'est façonnée que par l'opération de pressage.

**RECTIFIÉ (rett)**  
bord parfaitement rectiligne (présentant quelque fois un léger biseau au périmètre) obtenu par un équarrissage qui donne aux pièces des côtés de même taille, indépendamment des lots de production.

## • VARIATION DE NUANCE

indique la différence de couleur présentée par des carreaux non homogènes.  
V0 aspect très uniforme - V1 aspect uniforme  
V2 variations minimales - V3 variations modérées  
V4 variations importantes

## • FINITION DE SURFACE

**ANTICATA - NATURALE (nat)**  
**TEXTURE (txt) - VELVET:**  
surface qui n'a subi aucun traitement après la cuisson.

**LUX:**  
 finition de surface brillante, obtenue par le biais d'une légère abrasion mécanique de la surface.

**LEVIGATA (lev):**  
 finition de surface polie, obtenue en enlevant une faible couche en superficie pour mettre en valeur les caractéristiques esthétiques du produit.

**LAPPATA (lapp):**  
 surface rendue plus fluide et plus brillante par le biais d'un traitement mécanique après la cuisson.

**GRIP - TEXTURE GRIP:**  
 surface avec une résistance élevée à la glissance, laquelle permet des applications en extérieur.

## • JOINT

distance conseillée entre les carreaux.

## • SCHERBEN

**VOLLGEMISCHTES FEINSTEINZEUG UGL**  
ein produkt, das auf der oberfläche genau die farben zeigt, die den gesamten fliesenkörper durchziehen.

**GLASIERTES FEINSTEINZEUG MIT GEFÄRBTER MASSE GL**  
ein produkt, bei dem die masse des fliesenkörpers gefärbt wurde und das zusätzlich eine glasur auf der oberfläche aufweist.

**GLASIERTE, WEISSSCHERBIGE „MONOPOROSA“ GL**  
ein als wandfliese bestimmtes produkt mit poröser, weißlicher masse, das aus einem werkmaß hergestellt, glasiert und nur oberflächlich gefärbt wird.

**GLASIERTES FEINSTEINZEUG GL**  
ein produkt aus einfarbigem grundfeinsteinzeug, das seine farbige oberfläche ausschließlich durch die glasur erhält.

**LAMINIERTES FEINSTEINZEUG UGL**  
vollgemischtes durchgefärbtes feinsteinzeug, ergebnis einer innovativen verdichtungstechnologie. dieses produkt enthält einzigartige eigenschaften bezüglich formaten, stärke, leichtigkeit, beständigkeit und flexibilität.

**DOPPELTE PRESSUNG**  
ein produktionsprozess, der die verschiedenen farben der massen des fliesenkörpers in einem ersten pressvorgang mischt und dann die farben in den folgenden anwendungen durch eine zweite pressung verdichtet.

## • FLIESEN RAND

**NATURALE (nat)**  
ein rand, der ausschließlich durch die formung der presse entsteht.

**REKTIFIZIERTES (rett)**  
ein perfekt gerader rand (zum teil auch mit einer leichten abkantung an der oberfläche), der durch eine rechtwinklige bearbeitung entsteht, die die stücke, unabhängig zu welcher fertigungscharge sie gehören, auf ein übereinstimmendes seitenmaß bringt.

## • FARBABSTUFUNG

gibt den unterschied der einzelnen fliesen an, deren farbtönen nicht übereinstimmt.  
V0 sehr gleichmäßiges Aussehen - V1 gleichmäßiges Aussehen - V2 nur minimale Unterschiede - V3 mäßige Unterschiede - V4 bedeutende Unterschiede

## • OBERFLÄCHENAUSFÜHRUNGEN

**ANTICATA - NATURALE (nat)**  
**TEXTURE (txt) - VELVET:**  
eine oberfläche, die nach dem brennvorgang nicht bearbeitet wird.

**LUX:**  
lux glänzende oberfläche durch eine leicht mechanischen bearbeitung erreicht.

**LEVIGATA (lev):**  
polierte und glänzende oberfläche, ergebnis der entfernung einer kleinen materialschicht zur betonung der ästhetischen eigenschaften der oberfläche.

**LAPPATA (lapp):**  
eine oberfläche, die durch eine mechanische bearbeitung nach dem brennvorgang glatt und glänzend wird.

**GRIP - TEXTURE GRIP:**  
oberfläche mit hoch rutsch festigkeit bezeichnet. für außen beriecht geeignet.

## • FUGE

der zwischen den fliesen empfohlene abstand.

# LEA CERAMICHE SVILUPPO ECOSOSTENIBILE

LEA CERAMICHE 100% ECO FRIENDLY - LEA CERAMICHE DÉVELOPPEMENT ÉCHO-SOSTENIBLE  
LEA CERAMICHE UMWELTSCHONENDE NACHHALTIGE ENTWICKLUNG



## Lea Ceramiche e l'ambiente

Da sempre LEA CERAMICHE considera la tutela dell'ambiente un aspetto di grande rilevanza

- investendo in modo deciso nell'acquisto delle migliori tecnologie presenti sul mercato per ridurre al minimo gli impatti ambientali delle proprie attività
- dotando tutti i dipendenti di un ambiente di lavoro ottimale
- ottenendo prestigiose certificazioni ambientali

Le collezioni più importanti di Lea Ceramiche hanno ottenuto il prestigioso marchio ecologico **ECOLABEL** (Reg. CE 66/2010), rilasciato dall'Unione Europea solo ai materiali con il più basso impatto ambientale.

Tutti i prodotti LEA CERAMICHE sono realizzati presso stabilimenti produttivi dotati di **Sistemi di Gestione Ambientale certificati: ISO 14001: 2004** (norma riconosciuta a livello internazionale) **EMAS** (Regolamento Europeo - Reg. CE 1221/09)

## Documentazioni

Le **Dichiarazioni Ambientali EMAS** dei siti produttivi, i documenti che descrivono le prestazioni degli stabilimenti in termini di salvaguardia dell'ambiente e tutti gli obiettivi che LEA CERAMICHE si pone nell'ottica del miglioramento continuo, sono disponibili sul sito Internet [www.ceramichelea.it](http://www.ceramichelea.it).

## Lea Ceramiche and the environment

Lea Ceramiche has always considered environmental protection a matter of great importance

- investing in the best technologies on the market to minimize the environmental impact of its activities
- giving all employees an excellent working environment
- obtaining prestigious environmental certifications

The most important collections of Lea Ceramiche have been awarded the prestigious **ECOLABEL** (EC regulation 66/2010), issued by the European Union only to those products with the lowest environmental impact.

All LEA CERAMICHE products are manufactured in production sites that are certified with **Environmental Management Systems: ISO 14001: 2004** (internationally recognized standard) **EMAS** (European Regulation - EC Reg 1221/09)

## Documentation

The **EMAS Environmental Statements** of the production sites, documents describing the performance of production sites and all the objectives LEA Ceramiche strives to achieve in terms of environmental safeguard, are available on the website [www.ceramichelea.it](http://www.ceramichelea.it).

## Lea Ceramiche salvaguardia dell'ambiente

L'incessante ricerca di prestazioni di eccellenza in merito al rispetto dell'ambiente ha condotto LEA CERAMICHE al costante rispetto dei seguenti principi.



### RIUTILIZZO DEL 100% DEGLI SCARTI CRUDI

Il **100% degli scarti crudi** derivanti dal ciclo di produzione vengono **riutilizzati nella fase di preparazione dell'impasto**, contribuendo in modo sensibile alla salvaguardia delle risorse naturali riducendo l'estrazione di materie prime da cava.



### RIUTILIZZO/RICICLO DEL 100% DEGLI SCARTI COTTI

Gli scarti cotti sono completamente riutilizzati nel ciclo produttivo. Inoltre, a fine vita, le piastrelle LEA CERAMICHE possono essere riciclate come inerti per sottofondi di strade ed edifici, riducendo così l'uso di ghiaia ed inerti naturali comunemente utilizzati in edilizia.



### RICICLO DEL 100% DEI RIFIUTI NON CERAMICI

Il **100% dei rifiuti non ceramici** derivanti dalle attività produttive è **gestito in modo differenziato** e riciclato in altri processi produttivi.



### RIUTILIZZO DEL 100% DELLE ACQUE DI PROCESSO

La produzione di piastrelle di ceramica richiede ingenti quantitativi di acqua. Per salvaguardare questa importante risorsa naturale LEA CERAMICHE **riutilizza il 100% delle acque reflue** derivanti dal ciclo di produzione, generando una **riduzione fino all'80% del fabbisogno idrico degli stabilimenti**.



### BASSE EMISSIONI IN ATMOSFERA

Gli importanti investimenti attuati nelle migliori tecnologie a disposizione permettono di realizzare i prodotti LEA CERAMICHE **riducendo al minimo le emissioni gassose in atmosfera**, raggiungendo livelli 10 volte inferiori ai severi limiti ambientali richiesti della legislazione italiana.



### FORTE RIDUZIONE DEI CONSUMI ENERGETICI

L'uso di tecnologie all'avanguardia e di soluzioni impiantistiche ottimali riducono sensibilmente l'uso di gas metano nel processo produttivo.



### UTILIZZO DI IMBALLAGGI 100% RICICLABILI

I **materiali impiegati per gli imballaggi** dei prodotti LEA CERAMICHE (quali scatole, cartone, plastica, palette in legno, etc.) sono **completamente riciclabili**.



### PALLET FAO

LEA CERAMICHE utilizza pallet senza corteccia **conformi allo standard IPPC / FAO ISPM 15**, offrendo quindi ai Paesi importatori ogni garanzia per la salvaguardia del proprio patrimonio forestale.

## Lea Ceramiche cares for the environment

LEA CERAMICHE's incessant strive for excellence has led us to respect the following principles when dealing with the environment.

### 100% INDUSTRIAL WASTE REUSED – NON FIRED TILES

The **totality of the non fired material**, which does not comply with our high quality standards, **is reused in the production cycle**. As these products are not yet fired, they can be reinserted in the initial phases of the production cycle. **Recycling of this waste also reduces the need of raw materials.**

### 100% REUSE/RECYCLING OF THE INDUSTRIAL WASTE – FIRED TILES

The waste-fired tiles are fully reused in the production cycle. In addition, at the end of life, the tiles LEA CERAMICHE can be recycled as materials for substrates for roads and buildings, thus reducing the use of gravel and natural aggregates commonly used in building.

### 100% INDUSTRIAL WASTE RECYCLED – NON CERAMIC WASTE

The **totality of the non ceramic waste is differentiated and recycled** in other production cycles.

### 100% WASTE WATER RECYCLED – SAFEGUARD OF NATURAL RESOURCES

The production of tiles requires important amounts of water. So as to safeguard this precious resource **LEA CERAMICHE recycles 100% of waste water from the production cycle. This allows the reduction of water consumption up to 80%**. None of the water used in the production cycle is discharged into the ecosystem.

### LOW GAS EMISSIONS INTO THE ATMOSPHERE

LEA CERAMICHE **complies strictly to Italian Standards**. The strive for excellence has led us to invest in high quality technology that keeps **our emissions 10 times inferior the allowed limits**.

### METHANE CONSUMPTION IS HIGHLY REDUCED

By the use of up to date technologies and customized installations.

### 100% RECYCLABLE MATERIAL USED FOR PACKING

The materials used for the packing of LEA CERAMICHE products are **completely recyclable**. These materials include carton boxes, plastic materials, wooden pallets, etc.

### FAO PALLETS

For shipments LEA CERAMICHE uses debarked pallets (DB), **in accordance with the IPPC / FAO ISPM 15 standards**. This is a further warranty for the forest safeguard of countries importing LEA CERAMICHE products.

## Lea Ceramiche et l'environnement

Depuis toujours LEA CERAMICHE considère la protection de l'environnement un aspect très importante

- en investissant dans l'acquisition des technologies, les meilleures, pour réduire au minimum les impacts des propres activités
- donnant à tous ses employés, une ambiance de travail optimale
- obtenant des précieuses certifications

Les collections les plus importantes de Lea Ceramiche ont obtenu une prestigieuse certification écologique **ECOLABEL** (Reg. CE 66/2010), Reg. NOUS 66/2010, donnée par l'union Européenne seulement aux matériaux avec le plus bas impact sur l'environnement.

Tous les produits LEA CERAMICHE sont fabriqués dans des sites

productifs dotés de **Systèmes de Gestion Ambientale certifiés:**

**ISO 14001: 2004** (norme reconnue à niveau international)

**EMAS** (Règlement européen - Reg. CE 1221/09)

## Documentation

Les **Déclarations Ambientales EMAS** de sites de productions, les documents qui décrivent les performances en termes de sauvegarde de l'environnement et tous les objectifs qui se posent dans l'optique de l'amélioration continue sont disponibles sur le site internet [www.ceramichela.it](http://www.ceramichela.it).

## Lea Ceramiche préservation de l'environnement

La recherche incessante de prestations d'excellence afin de préserver l'environnement a conduit LEA CERAMICHE au suivi constant des principes suivants.

### REUTILISATION DE 100 % DES DÉCHETS BRUTS

100 % des déchets bruts provenant du cycle de production sont réutilisés pendant la phase de préparation de la pâte, contribuant sensiblement à la préservation des ressources naturelles réduisant l'extraction de matières premières minières.

### RÉUTILISATION/RECYCLAGE DE 100 % DES REBUTS DE CUISSON

Les rebuts de cuisson sont entièrement réutilisés dans le cycle de production. En fin de vie, les carreaux Lea Ceramiche peuvent par ailleurs être utilisés comme granulats pour les sous-bassements de routes et de bâtiments, ce qui permet de réduire l'utilisation de gravier et de granulats naturels habituellement utilisés en construction.

### RECYCLAGE DE 100 % DES DÉCHETS NON CÉRAMIQUES

100 % des déchets non céramiques provenant des activités de production sont triés de façon sélective puis recyclés dans d'autres processus de production.

### RÉUTILISATION DE 100 % DES EAUX DE TRAITEMENT

La production de carrelages demande une quantité d'eau considérable. Pour préserver cette ressource naturelle importante, LEA CERAMICHE **réutilise 100 % des eaux usées** provenant du cycle de production, ce qui permet de **réduire jusqu'à 80 % des besoins hydrauliques des usines.**

### BASSES ÉMISSIONS DANS L'ATMOSPHÈRE

Les importants investissements actuels dans les meilleures technologies qui sont à notre disposition permettent de réaliser les produits LEA CERAMICHE, **en réduisant au minimum les émissions de gaz dans l'atmosphère**, et en atteignant des niveaux dix fois inférieurs aux limites environnementales très sévères fixées par la législation italienne.

### FORTE RÉDUCTION DES CONSOMMATIONS ÉNERGÉTIQUES

L'utilisation de technologies de pointe et de solutions d'installations optimales permettent de réduire considérablement la consommation de gaz méthane dans le processus de production.

### UTILISATION D'EMBALLAGES 100 % RECYCLABLES

Les matériaux utilisés pour les emballages des produits LEA CERAMICHE (dont des boîtes, du carton, du plastique, des palettes en bois, etc.) sont complètement recyclables.

### PALETTES FAO

LEA CERAMICHE utilise des palettes sans écorce (DB) conformes aux normes IPPC / FAO ISPM 15, offrant donc aux Pays importateurs la garantie de la préservation du patrimoine forestier.

## Lea Ceramiche und die Umwelt

Seit immer betrachtet LEA CERAMICHE den Umweltschutz als Aspekt der höchsten Relevanz

- weil sie eindeutig in der Ausstattung der besten auf dem Markt vorhandenen Technologien investiert, um die Umweltbelastung ihrer Aktivitäten drastisch zu reduzieren
- weil sie einen sauberen, optimalen Arbeitsraum allen Mitarbeitern besorgt
- weil sie wichtige, internationale Öko-Zertifikate erhält

Die wichtigsten Kollektionen von LEA CERAMICHE haben das weltberühmte Zertifikat

„**ECOLABEL**“ (Reg. CE 66/2010) erhalten, das von der Europäische

Union ausschließlich den Materialien mit der geringsten

Umweltbelastung ausgestellt wird. Alle Produkte von LEA

CERAMICHE sind bei Produktionsstätten hergestellt, die mit

Umweltfreundlichen **Führungssystemen ausgestattet sind:**

**ISO 14001: 2004** (weltweit anerkannte Norm)

**EMAS** (europäische Regelung - Reg. CE 1221/09)

## Unterlagen zur Information

Die **Umweltschutz-Erklärungen „EMAS“** bezüglich der

Produktionsstätten d.h. die Unterlagen, die die Leistungen der

Fabrikgebäude betreffend Umweltschutz + alle Ziele der LEA

CERAMICHE hinsichtlich einer ständigen Verbesserung beschreiben,

sind auf der Webseite

[www.ceramichela.it](http://www.ceramichela.it) erhältlich.

## Lea Ceramiche Umweltschutz

Das unaufhörliche Bestreben nach hervorragenden Leistungen hinsichtlich der Umwelt brachte LEA CERAMICHE zur ständigen Einhaltung folgender Prinzipien.

### WIEDERVERWERTUNG VON 100 % DER ROHABFÄLLE

100% der Rohabfälle aus dem Produktionszyklus werden in der Vorbereitungsphase des Gemisches wiederverwertet und tragen somit ihren Teil zum Schutz der Naturressourcen bei, indem sie den Abbau von Rohmaterialien verringern.

### WIEDERVERWENDUNG/-VERWERTUNG ZU 100% DER BEIM BRENNEN DER FLIESEN ANFALLENDEN ABFÄLLE

Die beim Brennen der Fliesen anfallenden Abfälle werden vollständig wieder in den Produktionszyklus aufgenommen. Außerdem können die Fliesen Lea Ceramiche nach ihrem „Lebensende“ als inertes Material als Untergrund für Straßen oder Gebäude verwendet werden und somit den Einsatz von gewöhnlicherweise im Bauwesen eingesetzten Kies und inerten Naturmaterialien reduzieren.

### 100 % RECYCLING DES NICHT KERAMISCHEN ABFALLS

100 % der während dem Produktionsprozess anfallenden nicht **keramischen Abfälle** wird **getrennt verwaltet** und in anderen Produktionsprozessen wiederverwertet.

### WIEDERVERWERTUNG VON 100 % DES ABWASSERS

Die Herstellung von Keramikfliesen erfordert beträchtliche Wassermengen. Um diese wichtige Naturressource zu schützen, verwendet LEA CERAMICHE **100 % der Abwässer des Produktionszyklus** wieder und ermöglicht somit **eine Reduktion des Wasserbedarfs in den Anlagen von bis zu 80 %.**

### NIEDRIGE EMISSIONSWERTE

Dank der starken Investitionen in die modernsten, verfügbaren Produktionstechnologien ist es uns möglich, sämtliche Produkte von LEA CERAMICHE so herzustellen, dass **die Schadstoffemissionen in die Atmosphäre auf das Geringste reduziert werden.** Wir erreichen dabei ein Niveau, das 10 mal unter den strengen Grenzwerten der italienischen Gesetzgebung liegt.

### BEACHTLICHE REDUZIERUNG DES ENERGIEBEDARFS

Der Einsatz fortschrittlicher Technologien und optimaler Lösungen beim Bau der Anlagen reduzieren den Einsatz von Methan beim Produktionsprozess auf beachtliche Weise.

### VERWENDUNG VON 100 % RECYCLEBAREN VERPACKUNGEN

Die Materialien, die zur Verpackung der Produkte von LEA CERAMICHE verwendet werden (Schachteln, Kartons, Kunststoffe, Holzpaletten, usw.) sind vollständig recyclebar.

### FAO-PALETTE

LEA CERAMICHE verwendet gemäß dem Standard IPPC/FAO ISPM 15 Paletten ohne Rinde (DB) und gibt daher den Importländern die Garantie, den eigenen Waldbestand zu schützen.

# CERTIFICAZIONI DI PRODOTTO

PRODUCT CERTIFICATION

CERTIFICATIONS DE PRODUIT

BESCHEINIGUNG DES PRODUKTS

Di seguito riportate le certificazioni ottenute da Lea Ceramiche a testimonianza della massima attenzione e sensibilità verso le questioni etiche, ambientali e di sicurezza e qualità. Per maggiori dettagli e per scaricare i certificati vi invitiamo a consultare il nostro sito: [www.ceramichelea.it](http://www.ceramichelea.it).

Below are the certifications obtained by Lea Ceramiche attesting to the utmost attention and sensitivity shown towards ethical, environmental, safety and quality issues. For more details and to download the certificates, please visit our website: [www.ceramichelea.it](http://www.ceramichelea.it).

CERTIFICAZIONE CERTIFICATION	DESCRIZIONE	DESCRIPTION
	UPEC è una certificazione di prodotto rilasciata dall'istituto francese CSTB che verifica l'idoneità tecnica dei prodotti in relazione al tipo di destinazione d'uso.	UPEC is a product certification issued by the French institution CSTB, verifying the technical suitability of the products related to their intended use.
	La marcatura CE è la certificazione di sicurezza del prodotto richiesta dall'Unione Europea e ha lo scopo di salvaguardare la salute delle persone.	The CE mark is a safety certification required by the European Union with the intention of safeguarding health and safety.
	Il marchio KEY-MARK e il marchio Certiquality-UNI attestano che i prodotti certificati sono conformi alle normative europee per le piastrelle ceramiche.	The KEY-MARK and the Certiquality-UNI marks confirm that the certified products are compliant with the EU laws regarding ceramic tiles.
	La dichiarazione EPD è una dichiarazione volontaria applicabile a tutti i prodotti. È un importante strumento di rendicontazione e documentazione in tema di qualità ambientale dei prodotti.	The EPD declaration is a voluntary declaration that can be applied to all products. It is an important instrument to report on the environmental quality of a product.
	Ecolabel è un sistema di certificazione ambientale di prodotto creato dalla Comunità Europea (Regolamento CE n. 66/2010) che offre a tutti i consumatori la possibilità di acquistare merci eco-compatibili. Questa etichetta rappresenta un attestato di eccellenza perché viene concessa in base a una rigorosa analisi del ciclo di vita del prodotto (LCA).	Ecolabel is a system of environmental certifications created by the EU (CE Regulation 66/2010) offering all consumers the possibility to purchase eco-friendly goods. This label is a mark of excellence, as it is awarded after a strict analysis of the whole life-cycle of a product (LCA).
	Per gran parte dei suoi prodotti, Panariagroup ha ottenuto una certificazione relativa al contenuto di materiale riciclato pre-consumer. Questa caratteristica di eco-sostenibilità contribuisce all'ottenimento di crediti previsti da diversi standard edilizi internazionali.	For most of its products, Panariagroup achieved a certification related to the contents of recycled material pre-consumer. This character of eco-sustainability contributes to the achievement of credits required by several national building standards.
	Lea Ceramiche è membro del U.S. Green Building Council e del Green Building Council ITALIA, organizzazioni che promuovono la realizzazione di edifici ed opere nel rispetto dell'ambiente, della salute e del benessere delle persone che ci vivono e lavorano.	Lea Ceramiche is a member of the U.S. Green Building Council and of the Green Building Council ITALIA. These organizations promote the construction of buildings and other works which respect the environment as well as the health and well-being of the people who live and work within them.



Ci-après, les certifications obtenues par Lea Ceramiche qui témoignent de la plus haute attention et sensibilité envers les questions éthiques, environnementales, de sécurité et de qualité. Pour plus de détails et pour télécharger les certificats, nous vous invitons à consulter notre nouveau site : [www.ceramichelea.it](http://www.ceramichelea.it).

Im Folgenden finden Sie die Zertifizierungen, die Lea Ceramiche verliehen wurden als Anerkennung für deren große Bemühungen und Sorgfalt im Umgang mit ethischen, ökologischen, Sicherheits- und Qualitätsproblemen. Für weitere Details und um die Zertifikate herunterzuladen, besuchen Sie bitte unsere Website: [www.ceramichelea.it](http://www.ceramichelea.it)

CERTIFICATIONS BESCHEINIGUNG	DESCRIPTION	BESCHREIBUNG
	Il s'agit d'une certification de produit, délivrée par l'Établissement français CSTB, qui vérifie la conformité technique des produits de premier choix par rapport à la destination d'usage.	Es handelt sich um eine Produktzertifizierung, die vom französischen Institut CSTB ausgestellt wird. Die Behörde prüft die technische Eignung von Erzeugnissen erster Wahl im Verhältnis zu ihrem Verwendungszweck.
	La marque CE est la certification de sécurité des produits demandé par l'Union Européenne ayant comme objectif la protection et la santé des personnes.	Das CE- Kennzeichnung ist die von EU angefragte Zertifizierung für die Produkt- Sicherheit, und hat das Zweck die Gesundheit der Menschen zu schützen und die Güter in der Bauphase zu bewahren.
	Le Label KEY-MARK et le Label Certiquality-UNI attestent que les produits certifiés sont conformes aux normes européennes pour les carreaux céramiques.	Die Kennzeichnung KEY-MARK und die Kennzeichnung Certiquality-UNI bescheinigen, dass die zertifizierten Produkte den Europäischen Richtlinien für Keramikfliesen entsprechen.
	La Déclaration Environnementale Produit (DEP) communique de manière transparente les performances environnementales du grès cérame.	Die Umwelt-Produktdeklaration (EPD) teilt in einer transparenten Art und Weise die Umweltleistung von Feinsteinzeug.
	Ecolabel est un système de certification écologique de produit mis en place par la Communauté européenne (Règlement CE n° 66/2010). Il donne à l'ensemble des consommateurs la possibilité d'acheter des produits écologiquement efficaces. Ce label constitue un certificat d'excellence, car il n'est délivré qu'après une analyse scrupuleuse du cycle de vie (ACV).	Das Ecolabel, das von der Europäischen Union ins Leben gerufene Zertifizierungssystem (EG Verordnung Nr. 66/2010), bietet allen Verbrauchern die Möglichkeit, umweltfreundliche Produkte zu kaufen. Dieses Label zertifiziert ein ausgezeichnetes Niveau und wird nach einer strengen Analyse der Produktlebensdauer (LCA) gewährt.
	Pour la plupart de ses produits, Panariagroup a obtenu une certification liée au contenu du matériel pré-consumé recyclé. Cette caractéristique de l'éco-durabilité contribue à l'obtention de crédits fournis par différentes normes de construction internationales.	Für die meisten seiner Produkte hat Panariagroup gewonnen eine Zertifizierung in Bezug auf den Inhalt des Materials recycelter Pre-Consumer. Dieses Merkmal der ökologischen Nachhaltigkeit trägt dazu bei, Kredite von unterschiedliche internationale Baunormen.
	Lea Ceramiche est membre de l'U.S. Green Building Council et du Green Building Council d'Italie. Ces organisations promeuvent la réalisation de bâtiments et de travaux qui respectent l'environnement, la santé et le bien-être des personnes qui travaillent à la réalisation et de celles pour lesquelles elle est destinée.	Lea Ceramiche ist ein Mitglied des US-Green Building Councils und des Green Building Councils ITALIEN, beides Organisationen, die den Bau von Gebäuden und Strukturen unter Beachtung der Umwelt, Gesundheit und des Wohlbefindens der Menschen, die darin leben und arbeiten, fördern.

# CERTIFICAZIONE DEL SISTEMA QUALITÀ AZIENDALE

COMPANY QUALITY CONTROL CERTIFICATION

CERTIFICATIONS DU SYSTÈME DE QUALITÉ D'ENTREPRISE

QUALITÄTSBESCHEINIGUNG DER FIRMA

Di seguito sono riportate le certificazioni di sistema ottenute da Panariagroup per i suoi stabilimenti. Per quanto riguarda il sistema di gestione della qualità, la certificazione ISO 9001 si estende a tutte le divisioni commerciali e alle funzioni di servizio. Anche queste testimoniano l'impegno del Gruppo verso le questioni etiche, ambientali e di sicurezza e qualità.

Here are the system certifications achieved by Panariagroup in its plants. For what concerns quality control, the ISO 9001 certification is extended to all commercial divisions and services. This also is evidence of the Group's commitment towards ethical, environmental, safety and quality issues.

CERTIFICAZIONE  
CERTIFICATION

DESCRIZIONE  
DESCRIPTION

DESCRIPTION  
BESCHREIBUNG



Ai sensi della Certificazione ISO 9001, tutte le fasi del processo produttivo, a partire dall'arrivo delle materie prime fino alla scelta e confezionamento del prodotto finito, vengono opportunamente verificate da personale esperto attraverso accurati controlli di qualità. Il sistema qualità dei siti produttivi Panariagroup viene verificato con frequenza annuale da un ente certificatore esterno attraverso accurate visite ispettive.

In accordance to the ISO 9001 certification, every passage in the production process, from the arrival of the raw material to the packaging of the finished product, is verified by experienced personnel through accurate quality control. The quality of the Panariagroup production sites is audited yearly by an external agency through detailed visits.

Conformément à la Certification ISO 9001, toutes les phases du processus de production, à partir de l'arrivée des matières premières jusqu'à la sélection et le conditionnement du produit fini, sont adéquatement vérifiées par du personnel expérimenté qui effectue des contrôles de qualité approfondis. Le système qualité des sites de production Panariagroup est vérifié tous les ans par un organisme de certification extérieur au moyen de visites d'inspection précises.

Gemäß der Zertifizierung ISO 9001, werden alle Phasen des Produktionsprozesses, von der Ankunft der Rohstoffe bis zur Wahl und Verpackung des Endprodukts in geeigneter Weise von Fachpersonal durch eine sorgfältige Qualitätskontrolle überprüft. Das Qualitätssystem der Produktionsstätten der Panariagroup wird jährlich über eine externe Zertifizierungsstelle durch Inspektionsbesuche kontrolliert.



Ai fini della Certificazione ISO 14001 tutti gli aspetti ambientali inerenti all'attività di produzione di piastrelle vengono costantemente controllati, garantendo l'utilizzo delle migliori tecnologie presenti sul mercato per ridurre al minimo gli impatti ambientali generati. Il sistema ambientale dei siti produttivi Panariagroup viene verificato con frequenza annuale da un ente certificatore esterno attraverso accurate visite ispettive.

In accordance to the ISO 14001 certification, all the environmental aspects concerned in the production of our tiles are constantly monitored, guaranteeing the use of the best technologies on the market in order to reduce the environmental impact. The environmental system of the Panariagroup production sites is audited yearly by an external agency through detailed visits.

Aux fins de la Certification ISO 14001, tous les aspects environnementaux relatifs à l'activité de production de carreaux sont constamment contrôlés, garantissant l'utilisation des meilleures technologies présentes sur le marché afin de réduire au minimum les impacts environnementaux qui sont générés. Le système environnemental des sites de production Panariagroup est contrôlé tous les ans par un organisme de certification extérieur au moyen de visites d'inspection approfondies.

Für die Zwecke der ISO 14001-Zertifizierung werden alle mit der Herstellung von Fliesen zusammenhängende Umweltaspekte kontinuierlich überwacht und der Einsatz der besten Technologien auf dem Markt gewährleistet, um die Umweltbelastung auf ein Minimum zu reduzieren. Das Umweltsystem der Produktionsstätten der Panariagroup wird jährlich von einer externen Zertifizierungsstelle durch genaue Kontrollen überprüft.



Il sistema comunitario di ecogestione e audit EMAS per le organizzazioni richiede la creazione di un Sistema di Gestione Ambientale basato sul continuo miglioramento delle proprie prestazioni. Il sistema si fonda sulla creazione di un rapporto di collaborazione e fiducia con i dipendenti, con le istituzioni del territorio e con il pubblico. La Dichiarazione Ambientale è il documento finale di tale processo.

The EU EMAS Eco-Management and Audit Scheme for organisations requires the creation of a complete system of environmental management based on constant improvement. The system is based on the establishment of a rapport of cooperation and trust with employees, local authorities and the public. An Environmental Declaration is the final product of such process.

Le système communautaire de management environnemental et d'audit EMAS pour les organisations exige la création d'un Système de Gestion Environnemental basé sur l'amélioration constante des prestations. Le système est fondé sur la création d'un rapport de collaboration et de confiance avec les employés, avec les institutions du territoire et avec le public. La Déclaration Environnementale est le document final de ce processus.

Das EG-Umweltmanagement und Audit EMAS für die Organisationen erfordert die Erstellung eines Umweltmanagement-systems auf der Grundlage der kontinuierlichen Verbesserung der eigenen Leistungen. Das System basiert auf der Schaffung einer Beziehung der Zusammenarbeit und des Vertrauens mit den Mitarbeitern, den lokalen Institutionen und der Öffentlichkeit. Die Umwelterklärung ist das abschließende Dokument dieses Prozesses.

# PRODOTTI CERTIFICATI

360/361

CERTIFIED PRODUCTS

PRODUITS CERTIFIÉS

ZERTIFIZIERTE ERZEUGNISSE

serie series series serien	spessore thickness starke epaisseur	formato (cm) sizes (cm) formate (cm) formats (cm)	colori colors couleurs farben	classement upec	marchio certiquality-uni key mark n°concessione
basaltina stone project	11 mm	30x60	lappata naturale - sabbia - scalpellata - stuccata - texture	U3P3E3C2 U4P3E3C2	PT 0061
		60x60	lappata naturale - sabbia - scalpellata - stuccata - texture	U3P3E3C2 U4P3E3C2	
	12 mm	60x120	lappata naturale - sabbia - stuccata	U3P3E3C2 U4P3E3C2	
bio recover	12 mm	20x180	warm cream - golden flame - old walnut		PT 0061
	10,5 mm	20x121,5	warm cream - golden flame - old walnut		
cliffstone	11 mm	90x90	white dover - beige madeira - taupe moher grey tenerife		PT 0061
	10 mm	60x120 60x90 60x60 40x60 30x60 20x60	white dover - beige madeira - taupe moher grey tenerife		
dreaming	10 mm	60x60 30x60	calacatta shine - cristal white - romance safari passion pulpis - bianco statuario - gray stone		PT 0038
	11 mm	75x75	calacatta shine - cristal white - romance safari passion pulpis - bianco statuario - gray stone		
	10 mm	60x60 30x60	calacatta shine lux - cristal white lux romance safari lux - passion pulpis lux bianco statuario lux - gray stone lux		PT 0038
	11 mm	73x73	calacatta shine lux - cristal white lux romance safari lux - passion pulpis lux bianco statuario lux - gray stone lux		
metropolis	10 mm	30x60 60x60	berlin night - london gray - milano ecru new york coal - paris amande - rio coffee shanghai iron - tokyo white	U4P3E3C2	PT 0061
		11 mm	45x90 90x90	berlin night texture - milano ecru texture rio coffee texture - shanghai iron texture tokyo white texture	
	10 mm		30x60 60x60 60,4x60,4	endre - charcoal - lime - silt	
tecn quartz	12 mm	20x30	doral - silver - gneiss	U4P4+E3C2	
	12 mm	20x60 40x60 60x60	doral - silver - gneiss	U4P3E3C2	
		30x30 30x60	doral - silver - gneiss - hard black	U4P4+E3C2	
	12 mm	20x30 20x60	hard black	U4P4E3C2	
	12 mm	60x60	hard black	U4P4+E3C2	
waterfall	10,5 mm	30x60 60x60 45x90 90x90 60x120	ivory flow - silver flow - gray flow - dark flow		PT0061

# CARATTERISTICHE TECNICHE: GRES PORCELLANATO 10 - 20mm

TECHNICAL FEATURES PORCELAIN TILES

CARACTÉRISTIQUES TECHNIQUES  
DU GRÉS CÉRAME

TECHNISCHE EIGENSCHAFTEN  
DES GRES FEINSTEINZEUGS

CONFORME - ACCORDING TO - CONFORME - GEMÄß: ISO 13006 G - EN 14411 G

CARATTERISTICHE TECNICHE TECHNICAL FEATURES CARACTÉRISTIQUES TECHNIQUES TECHNISCHE EIGENSCHAFTEN		metodo di prova test method méthode d'essai prüfmethode	
	<b>assorbimento d'acqua</b> water absorption absorption d'eau wasserabsorption	ISO 10545-3	
	<b>sforzò di rottura (S)</b> breaking strength (S) chargement de rupture (S) bruchlast (S)	ISO 10545-4	
	<b>resistenza alla flessione</b> modulus of rupture résistance à la flexion beigefestigkeit	ISO 10545-4	
	<b>resistenza all'abrasione profonda</b> résistance to deep abrasion résistance à l'abrasion profonde widerstand gegen tiefenabrieb	ISO 10545-6	
	<b>dilatazione termica lineare</b> linear thermal expansion dilatation thermique linéaire thermische dilatation	ISO 10545-8	
	<b>resistenza alle macchie</b> stain resistance résistance aux taches fleckenbeständigkeit	ISO 10545-14	
	<b>resistenza attacco chimico*</b> chemical resistance résistance chimique chemische beständigkeit	ISO 10545-13	
	<b>resistenza al gelo</b> frost resistance résistance au gel frostbeständigkeit	ISO 10545-12	
	<b>reazione al fuoco</b> fire reaction réaction au feu Brandverhalten	EN 13823	EN 9239-1
	<b>conducibilità termica</b> thermal conductivity conductivité thermique Wärmeleitfähigkeit	EN 12524	
	<b>caratteristiche dimensionali</b> dimensions caracteristiques dimensionnelles sitenmasse	<b>lunghezza e larghezza</b> length and width longueur et largeur länge und breite	ISO 10545-2
		<b>retteilinearità spigoli</b> straightness of sides rectitude des arêtes kantengeradheit	ISO 10545-2
		<b>ortogonalità</b> rectangularity orthogonalité rechtwinkligkeit	ISO 10545-2
		<b>planarità</b> warpage planéité ebenflächigkeit	ISO 10545-2
		<b>spessore</b> thickness épaisseur stärke	ISO 10545-2









\*ad esclusione dell'acido fluoridrico e suoi derivati  
excluding hydrofluoric acid and its derivatives  
sauf l'acide fluorhydrique et ses dérivés  
ausgenommen den fluorwasserstoff und seine  
derivate

	LEA	LEA	LEA
<b>requisiti prescritti</b> required values / valeur requise vorgeschriebener wert <b>ISO 13006 - G / EN 14411 - G</b> <b>gruppo / group B1a</b>	<b>valori medi</b> average values valeurs moyens durchschnittliche werte <b>UGL: non smaltato</b> UGL: unglazed	<b>valori medi</b> average values valeurs moyens durchschnittliche werte <b>GL: smaltato - levigato</b> GL: glazed - polished	<b>valori medi</b> average values valeurs moyens durchschnittliche werte <b>UGL: levigato - lappato</b> UGL: polished - lappato
≤ 0,5%	0,05%	0,05%	0,05%
≥ 1300 N	<b>conforme</b> compliant conforme gemäß <b>13600 N (20mm) ⊕ SYS L2</b>	<b>conforme</b> compliant conforme gemäß	<b>conforme</b> compliant conforme gemäß
≥ 35 N/mm <sup>2</sup>	50 N/mm <sup>2</sup>	50 N/mm <sup>2</sup>	50 N/mm <sup>2</sup>
≤ 175 mm <sup>3</sup>	145 mm <sup>3</sup>	<b>non applicabile</b> not applicable no applicable nicht anwendbar	145 mm <sup>3</sup>
<b>requisito non previsto</b> no provision non prévu nicht erforderlich	$\alpha \leq 7 \times 10^{-6} \text{ } ^\circ\text{C}^{-1}$	$\alpha \leq 7 \times 10^{-6} \text{ } ^\circ\text{C}^{-1}$	$\alpha \leq 7 \times 10^{-6} \text{ } ^\circ\text{C}^{-1}$
classe 3 minimo	<b>5 (resistente)</b> (resistant) (résistant) (beständig)	<b>5 (resistente)</b> (resistant) (résistant) (beständig) <b>≥ 3 (lux)</b>	<b>5 (resistente)</b> (resistant) (résistant) (beständig) <b>≥ 3 (lux)</b>
<b>come indicato dal produttore</b> as indicated by manufacturer comme indiqué par le producteur wie vom hersteller angegeben	<b>LA - HA (resistente)</b> (resistant) (résistant) (beständig)	<b>LA - HA (resistente)</b> (resistant) (résistant) (beständig)	<b>LA - HA (resistente)</b> (resistant) (résistant) (beständig)
<b>nessuna alterazione</b> no alterations aucune altération keine änderung	<b>resistente</b> resistant résistant beständig	<b>resistente</b> resistant résistant beständig	<b>resistente</b> resistant résistant beständig
<b>CPR (UE) 305/2011, 2000/147/CE,</b> <b>UNI EN 13501-1</b>	<b>Classe / Class A1 (wall)</b> <b>Classe / Class A1<sub>f</sub> (floor)</b>	<b>Classe / Class A1 (wall)</b> <b>Classe / Class A1<sub>f</sub> (floor)</b>	<b>Classe / Class A1 (wall)</b> <b>Classe / Class A1<sub>f</sub> (floor)</b>
-	$\lambda = 1,3 \text{ W/m}^\circ \text{ k} / 0.7 \text{ BTU/ft h}^\circ \text{ F}$	$\lambda = 1,3 \text{ W/m}^\circ \text{ k} / 0.7 \text{ BTU/ft h}^\circ \text{ F}$	$\lambda = 1,3 \text{ W/m}^\circ \text{ k} / 0.7 \text{ BTU/ft h}^\circ \text{ F}$
± 0,6%	<b>conforme</b> compliant conforme gemäß	<b>conforme</b> compliant conforme gemäß	<b>conforme</b> compliant conforme gemäß
± 0,5%	<b>conforme</b> compliant conforme gemäß	<b>conforme</b> compliant conforme gemäß	<b>conforme</b> compliant conforme gemäß
± 0,6%	<b>conforme</b> compliant conforme gemäß	<b>conforme</b> compliant conforme gemäß	<b>conforme</b> compliant conforme gemäß
± 0,5%	<b>conforme</b> compliant conforme gemäß	<b>conforme</b> compliant conforme gemäß	<b>conforme</b> compliant conforme gemäß
± 5%	<b>conforme</b> compliant conforme gemäß	<b>conforme</b> compliant conforme gemäß	<b>conforme</b> compliant conforme gemäß

# TECHNICAL CHARACTERISTICS: PORCELAIN TILES

(AMERICAN STANDARDS)

ACCORDING TO ANSI A 137.1 GLAZED AND UNGLAZED PORCELAIN TILES (CLASS P1)

TECHNICAL FEATURES	test method	
 water absorption	ASTM C373	
 breaking strength	ASTM C648	
 deep abrasion resistance	ASTM C1243	
 linear thermal expansion	ASTM C372	
 stain resistance	ASTM C1378	
 chemical resistance*	ASTM C650	
 frost resistance	ASTM C1026	
 flame spread	ASTM E84	
 dimensions	edge warpage	ASTM C485
	diagonal warpage	ASTM C485
	nominal dimensions	ASTM C499
	calber range	ASTM C499
	thickness	ASTM C499
	wedging	ASTM C502

\*excluding hydrofluoridric acid and its derivatives

		LEA	LEA	LEA
required values		average values	average values	average values
ANSI A 137.1		UGL: unglazed	GL: glazed - polished	UGL: polished - lappato
≤ 0.5%		0.05%	0.05%	0.05%
≥ 250 lbf		compliant 2800 lbf (20mm) ⊕ SYS L2	compliant	compliant
≤ 175 mm <sup>3</sup>		145 mm <sup>3</sup>	not applicable	145 mm <sup>3</sup>
no provision		$\alpha \leq 8 \times 10^{-6} \text{ } ^\circ\text{C}^{-1}$ $\alpha \leq 4.4 \times 10^{-6} \text{ } ^\circ\text{F}^{-1}$	$\alpha \leq 8 \times 10^{-6} \text{ } ^\circ\text{C}^{-1}$ $\alpha \leq 4.4 \times 10^{-6} \text{ } ^\circ\text{F}^{-1}$	$\alpha \leq 8 \times 10^{-6} \text{ } ^\circ\text{C}^{-1}$ $\alpha \leq 4.4 \times 10^{-6} \text{ } ^\circ\text{F}^{-1}$
as indicated by manufacturer		A resistant	A resistant C (lux)	A resistant
as indicated by manufacturer		A resistant	A resistant	A resistant
as indicated by manufacturer		resistant	resistant	resistant
-		Class A	Class A	Class A
rectified ± 0.40% or max ± 0.05 inch for tiles up to 24"x24" or max ± 0.07 inch for tiles larger than 24"x24"	calibrated ± 0.75% or max ± 0.09 inch	compliant	compliant	compliant
rectified ± 0.40% or max ± 0.07 inch	calibrated ± 0.50% or max ± 0.08 inch	compliant	compliant	compliant
rectified - 3.0% / + 2.0% of nominal dimensions	calibrated ± 3.0% of nominal dimensions	± 1.5%	± 1.5%	± 1.5%
rectified ± 0.25% or max ± 0.03 inch	calibrated ± 0.50% or max ± 0.08 inch	compliant	compliant	compliant
≤ 0.040 inch	≤ 0.040 inch	≤ 0.030 inch	≤ 0.030 inch	≤ 0.030 inch
rectified ± 0.25% or max ± 0.03 inch	calibrated ± 0.50% or max + 0.08 inch	compliant	compliant	compliant

# CARATTERISTICHE TECNICHE: GRES LAMINATO

TECHNICAL FEATURES LAMINATED  
PORCELAIN

CARACTÉRISTIQUES TECHNIQUES  
DU GRÈS LAMINÉ

TECHNISCHE EIGENSCHAFTEN  
DES LAMINIERTEN FEINSTEINZEUGS

CONFORME - ACCORDING TO - CONFORME - GEMÄß: ISO 13006 G - EN 14411 G

	CARATTERISTICHE TECNICHE TECHNICAL FEATURES CARACTÉRISTIQUES TECHNIQUES TECHNISCHE EIGENSCHAFTEN	metodo di prova test method méthode d'essai prüfmethode
	<b>assorbimento d'acqua</b> water absorption absorption d'eau wasserabsorption	ISO 10545-3
	<b>resistenza alla flessione</b> modulus of rupture résistance à la flexion beigefestigkeit	ISO 10545-4
	<b>resistenza all'abrasione profonda</b> résistance to deep abrasion résistance à l'abrasion profonde widerstand gegen tiefenabrieb	ISO 10545-6
	<b>dilatazione termica lineare</b> linear thermal expansion dilatation thermique linéaire thermische dilatation	ISO 10545-8
	<b>resistenza alle macchie</b> stain resistance résistance aux taches fleckenbeständigkeit	ISO 10545-14
	<b>resistenza attacco chimico**</b> chemical resistance résistance chimique chemischee beständigkeit	ISO 10545-13
	<b>resistenza al gelo</b> frost resistance résistance au gel frostbeständigkeit	ISO 10545-12
	<b>reazione al fuoco</b> fire reaction réaction au feu Brandverhalten	EN 13823 EN 9239-1
	<b>conducibilità termica</b> thermal conductivity conductivité thermique Wärmeleitfähigkeit	EN 12524
	<b>caratteristiche dimensionali</b> dimensions caracteristiques dimensionnelles sctenmasse	<b>lunghezza e larghezza</b> length and width longueur et largeur länge und breite
		ISO 10545-2
		<b>retteilinearità spigoli</b> straightness of sides rectitude des arêtes kantengeradheit
		ISO 10545-2
		<b>ortogonalità</b> rectangularity orthogonalité rechtwinkligkeit
		ISO 10545-2
		<b>planarità</b> warpage planéité ebenflächigkeit
		ISO 10545-2
		<b>spessore</b> thickness épaisseur stärke
		ISO 10545-2

\* **valore riferito al solo materiale ceramico**  
value referred to ceramic material only  
valeur qui se réfère uniquement au matériel  
céramique  
der wert bezieht sich ausschließlich auf  
keramisches material











\*\***ad esclusione dell'acido fluoridrico e suoi  
derivati**  
excluding hydrofluoridric acid and its derivatives  
sauf l'acide fluorhydrique et ses dérivés  
ausgenommen den fluorwasserstoff und seine  
derivate



	LEA	LEA
<b>requisiti prescritti</b> required values valeur requise vorgeschriebener wert <b>ISO 13006 - G / EN 14411 - G</b> <b>Bla UGL</b>	<b>valori medi</b> average values valeurs moyens durchschnittliche werte <b>slimtech 3plus</b> <b>(lastra + fibra di vetro)</b> (slab + fiberglass)	<b>valori medi</b> average values valeurs moyens durchschnittliche werte <b>slimtech 5plus</b> <b>(lastra + fiba di vetro)</b> (slab + fiberglass)
≤ 0,5%	0,1%*	0,1%*
≥ 35 N/mm <sup>2</sup>	50 N/mm <sup>2</sup>	50 N/mm <sup>2</sup>
≤ 175 mm <sup>3</sup>	conforme compliant conforme gemäß	conforme compliant conforme gemäß
<b>requisito non previsto</b> no provision non prévu nicht erforderlich	$\alpha \leq 7 \times 10^{-6} \text{ } ^\circ\text{C}^{-1}$	$\alpha \leq 7 \times 10^{-6} \text{ } ^\circ\text{C}^{-1}$
classe 3 min.	<b>5 (resistente)</b> (resistant) (résistant) (beständig)	<b>5 (resistente)</b> (resistant) (résistant) (beständig) <b>C (lev)</b>
<b>come indicato dal produttore</b> as indicated by manufacturer comme indiqué par le producteur wie vom hersteller angegeben	<b>LA - HA (resistente)</b> (resistant) (résistant) (beständig)	<b>LA - HA (resistente)</b> (resistant) (résistant) (beständig) <b>LB - HB (lev)</b>
<b>nessuna alterazione</b> no alterations aucune altération keine änderung	<b>resistente</b> resistant résistant beständig	<b>resistente</b> resistant résistant beständig
<b>CPR (UE) 305/2011, 2000/147/CE,</b> <b>UNI EN 13501-1</b>	<b>Classe / Class A2 s1,d0 (wall)</b> <b>Classe / Class A2<sub>fl</sub> s1 (floor)</b>	<b>Classe / Class A2 s1,d0 (wall)</b> <b>Classe / Class A2<sub>fl</sub> s1 (floor)</b>
-	$\lambda = 1,3 \text{ W/m}^\circ \text{ k} / 0.7 \text{ BTU/ft h}^\circ \text{ F}$	$\lambda = 1,3 \text{ W/m}^\circ \text{ k} / 0.7 \text{ BTU/ft h}^\circ \text{ F}$
± 0,6%	conforme compliant conforme gemäß	conforme compliant conforme gemäß
± 0,5%	conforme compliant conforme gemäß	conforme compliant conforme gemäß
± 0,6%	conforme compliant conforme gemäß	conforme compliant conforme gemäß
± 0,5%	conforme compliant conforme gemäß	conforme compliant conforme gemäß
± 5%	conforme compliant conforme gemäß	conforme compliant conforme gemäß

# TECHNICAL FEATURES: LAMINATED PORCELAIN

(AMERICAN STANDARDS)

ACCORDING TO ANSI A 137.3 (BACK LAYERED GAUGED PORCELAIN SLABS)		
TECHNICAL FEATURES	test method	
 water absorption	ASTM C373	
 modulus of rupture	ASTM C1505	
 breaking strength	ASTM C1505	
 deep abrasion resistance	ASTM C1243	
 linear thermal expansion	ASTM C372	
 stain resistance	ASTM C1378	
 chemical resistance**	ASTM C650	
 frost resistance	ASTM C1026	
 flame spread	ASTM E84	
 thickness variation	ASTM C499	
	nominal dimensions	ASTM C499
	caliber range	ASTM C499
	thickness	ASTM C499
	thickness variation	ASTM C499
	wedging	ASTM C502

\*value referred to ceramic material only

\*\*excluding hydrofluoric acid and its derivatives

	LEA	LEA
requirements	average values	average values
ANSI A137.3 porcelain tile - class P1	slimtech 3plus (slab + fiberglass)	slimtech 5plus (slab + fiberglass)
≤ 0,5%	0.1%*	0.1%*
≥ 6000 lbf	≥ 6000 lbf	≥ 6000 lbf
thickness 3.5 - 4.9 mm: ≥ 85 lbf thickness 5 - 6.5 mm: ≥ 175 lbf	≥ 85 lbf (3Plus o Plus 3.5 mm) ≥ 175 lbf (5Plus o Plus 5.5 mm)	≥ 85 lbf (3Plus o Plus 3.5 mm) ≥ 175 lbf (5Plus o Plus 5.5 mm)
≤ 175 mm <sup>3</sup>	compliant	compliant
no provision	$\alpha \leq 4.4 \times 10^{-6} \text{ } ^\circ\text{F}^{-1} / \alpha \leq 8 \times 10^{-6} \text{ } ^\circ\text{C}^{-1}$	$\alpha \leq 4.4 \times 10^{-6} \text{ } ^\circ\text{F}^{-1} / \alpha \leq 8 \times 10^{-6} \text{ } ^\circ\text{C}^{-1}$
as indicated by manufacturer	class A resistant	class A resistant class C (lev)
as indicated by manufacturer	class A resistant class C (lev)	class A resistant class C (lev)
as indicated by manufacturer	resistant	resistant
-	class A	class A
0.5 mm (0.02")	compliant	compliant
Max ±3.0% of nominal dimensions	compliant	compliant
Max ±0.25% or max ±0.03"	compliant	compliant
Max ±0.5 mm (±0.02") from nominal thickness	compliant	compliant
0.5 mm (0.02")	compliant	compliant
Max ±0.25% or max ±0.03"	compliant	compliant

# CARATTERISTICHE PRODOTTO: LEALAB - TYPE32 - PAD

PRODUCT CHARACTERISTICS:  
LEALAB - TYPE32 - PAD

CARACTÉRISTIQUES DU PRODUIT:  
LEALAB - TYPE32 - PAD

PRODUKT-EIGENSCHAFTEN:  
LEALAB - TYPE32 - PAD

<b>inchiostri</b> inks encres Tinten	<b>base acqua</b> water-based base eau auf Wasserbasis
<b>protettivi</b> protective layers protecteurs Schutzmittel	<b>base acqua</b> water-based base eau auf Wasserbasis
<b>resistenza dei colori alla luce DIN 51094</b> resistance of colours to light DIN 51094 résistance des couleurs à la lumière DIN 51094 Lichtbeständigkeit der Farben nach DIN 51094	<b>superficie inalterata</b> surface unaltered surface inaltérée unveränderte Oberfläche
<b>resistenza attacco chimico ISO 10545-13</b> chemical resistance ISO 10545-13 résistance chimique ISO 10545-13 chemischee beständigkeit ISO 10545-13	<b>GLA - GHA resistente</b> GLA - GHA resistant GLA - GHA résistant GLA - GHA beständig
<b>resistenza alle macchie</b> stain resistance résistance aux taches fleckenbeständigkeit	<b>resistente al contatto con alimenti e bevande</b> resistant to contact with food and drink résistant au contact avec les aliments et les boissons Widerständigkeit beim Kontakt mit Lebensmitteln und Getränken
<b>pulizie quotidiane</b> daily cleaning nettoyages quotidiens Tägliche Reinigung	<b>utilizzare solo detergenti neutri, non utilizzare spugne o paste abrasive</b> use only neutral detergents, do not use abrasive sponges or paste utiliser uniquement des détergents neutres, ne pas utiliser d'éponges ou de pâtes abrasives nur neutralen Reinigungsmitteln verwenden, keine Schleifmittel oder Schleifschwämme verwenden
<b>resistenza superficiale</b> surface strength surface résistante Oberflächenwiderstand	<b>per preservare l'unicità della superficie evitare il contatto con elementi graffianti</b> to preserve the integrity of the surface avoid contact with abrasive materials a fin de préserver le caractère unique de la surface, évitez le contact avec des éléments abrasifs Für den Erhalt der Einzigartigkeit der Oberfläche den Kontakt mit kratzenden Elementen vermeiden
<b>taglio</b> cut découpe Schnitt	<b>per garantire l'impermeabilità della superficie, in caso di necessità di tagliare la singola lastra stuccare il bordo tagliato utilizzando prodotti epossidici *</b> in order to guarantee the impermeability of the surface, if it becomes necessary to cut the individual slab the cut edge must be plastered with an epoxy product pour garantir l'étanchéité de la surface, en cas de nécessité de couper la plaque seule plâtrez le bord découpé en utilisant des produits époxydes Zur Gewährleistung der Dichtheit der Oberfläche, die einzelne Platte falls notwendig schneiden und den geschnittenen Rand mit Epoxydprodukten behandeln
<b>stucco</b> grout mastic Fugenmaterial	<b>il prodotto si può stuccare sia con prodotti epossidici che con prodotti cementizi;</b> <b>* in caso di utilizzo con stucchi epossidici proteggere la superficie con nastro adesivo per mascheratura</b> the product can be grouted using both epoxy and cement products; * if epoxy grouts are used, protect the surface with masking tape le produit peut être enduit avec des mastics à base d'époxy ou de ciment; * si l'on utilise des mastics époxy, protéger la surface avec du ruban adhésif à protection das Produkt kann man mit Epoxyd-oder-Zementfugen ausfügen; * Beim Verwenden von Epoxyd-Fugenmaterial muss man die Oberfläche sorgfältig schützen Mit Klebband

# MANUALI TECNICI

TECHNICAL MANUALS

MANUELS TECHNIQUES

TECHNISCHE HANDBÜCHER

370 / 371

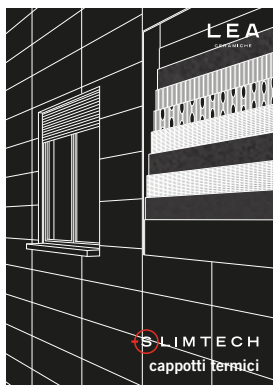

**CAPPOTTI TERMICI**  
external wall thermal insulation  
murs manteaux thermiques  
Wärmedämmungen

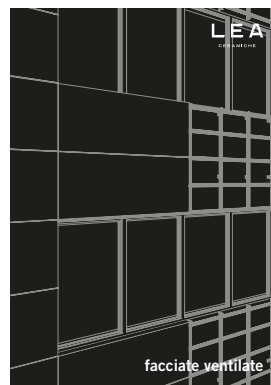

**FACCIAE VENTILATE**  
ventilated walls  
façades ventilées  
Hinterlüftete Fassaden

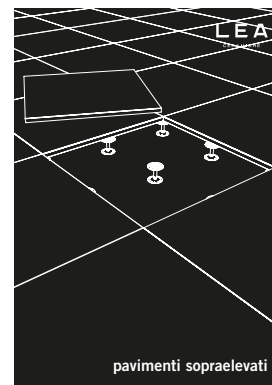

**PAVIMENTI SOPRAELEVATI**  
raised floors  
sols surélevés  
Doppelboden

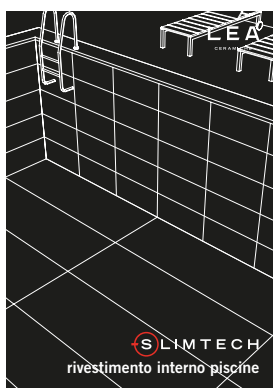

**RIVESTIMENTO INTERNO PISCINE**  
swimming pools  
revêtements piscines  
Schwimmbeckenverkleidung

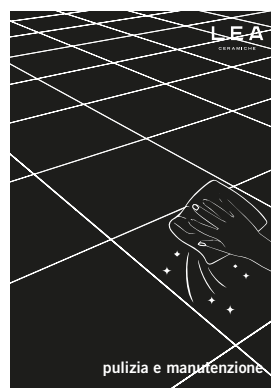

**PULIZIA E MANUTENZIONE**  
cleaning and maintenance  
nettoyage et entretien  
Reinigung und Wartung

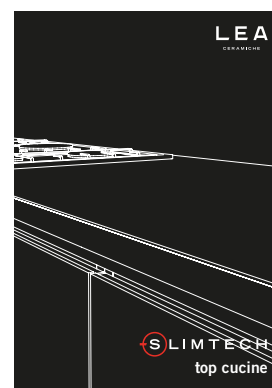

**TOP CUCINE**  
kitchen countertops  
plan de travail cuisine  
Küchenarbeitsplatte

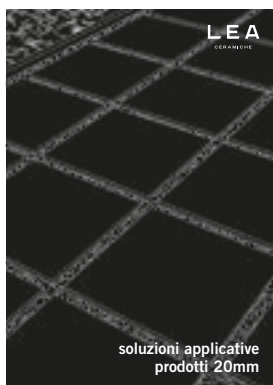

**SOLUZIONI APPLICATIVE PRODOTTI 20mm**  
application solutions for 20mm products  
solutions applicatives produit 20mm  
Anwendungslösungen für 20mm Produkte



**MANUALE TECNICO SLIMTECH**  
slimtech technical manual  
manuel technique slimtech  
slimtech technisches handbuch



**MANUALE TECNICO PROTECT**  
protect technical manual  
manuel technique protect  
protect technisches handbuch

I manuali tecnici sono disponibili sul sito internet [www.ceramichelea.com](http://www.ceramichelea.com)

The technical manual is available on the website [www.ceramichelea.com](http://www.ceramichelea.com)  
Les manuels techniques sont disponibles sur le site Internet [www.ceramichelea.com](http://www.ceramichelea.com)  
Die Technischen Broschüren sind auf der Webseite [www.ceramichelea.it](http://www.ceramichelea.it) erhältlich.

# INFORMAZIONI PER LA PULIZIA E LA MANUTENZIONE

Prima di pulire una superficie piastrellata è bene:

1. Verificare sul catalogo generale la **resistenza agli agenti chimici** delle piastrelle posate;
2. Effettuare un test preliminare direttamente sulle piastrelle posate, ponendo il detergente da utilizzare a contatto con le piastrelle per tempi uguali a quelli che si useranno poi sul cantiere;
3. Assicurarsi che i detersivi da usare **non contengano** acido fluoridrico e/o suoi derivati, poiché tali sostanze, per loro peculiarità, aggrediscono tutti i prodotti ceramici.

Si riportano di seguito alcune indicazioni per le pulizie di fine cantiere ("dopo posa"), quotidiane, straordinarie, per la rimozione di cere e patine lucidanti e per eventuali manutenzioni straordinarie.

## PULIZIA "DOPO POSA"

1. La pulizia "dopo posa" serve per rimuovere i residui di stucchi per le fughe, cemento, calce, boiaccia. È obbligatoria a fine cantiere, sia per le piastrelle smaltate che per quelle non smaltate.
2. Una pulizia "dopo posa" male effettuata, o addirittura non fatta, è spesso causa di aloni che impediscono di mantenere pulito il pavimento nonostante una buona pulizia quotidiana.
3. Quando possibile, specialmente per superfici medio-grandi, si consiglia l'uso di monospazzola con dischi morbidi (bianchi oppure beige).
4. Pulizia stucchi cementizi miscelati con acqua  
Si effettua con specifici detersivi a base di acidi tamponati e diluiti. Alcuni di questi, facilmente reperibili in commercio, sono riportati nella seguente tabella.

RESIDUO DA RIMUOVERE	TIPO DI DETERGENTE	NOME DETERGENTI	PRODUTTORE
stucchi cementizi boiaccia cemento calce	a base di acidi tamponati	keranet	mapei
		cement remover	faberchimica
		deterdek	fila
		trek	kiter
		zementschleierentferner	lithofin
		hmk r63	hmk
		solvacid	geal
		bonaclean / bclean	bonasystems italia
		bonadecon / bdecon (*)	bonasystems italia

Salvo diversa indicazione di LEA CERAMICHE, seguire attentamente le modalità d'uso indicate sulle confezioni dai fabbricanti. (\*) Specifico per prodotti non resistenti agli acidi.

## INDICAZIONI PER LA PULIZIA "DOPO POSA":

1. Effettuare la pulizia dopo 4-5 giorni dalla stuccatura (lo stucco deve indurire) e non oltre 10 giorni. Oltre questi tempi la pulizia può diventare molto più laboriosa.
2. Bagnare con acqua il pavimento prima delle operazioni di pulizia. In questo modo le stuccature vengono impregnate dall'acqua e viene ridotto il contatto con i detersivi.
3. Lasciare agire i detersivi per tempi limitati, risciacquando bene con acqua appena possibile.
4. Non deve essere eseguita se le superfici piastrellate sono molto calde (es. esposte al sole nei mesi più caldi), perché diviene più severa l'azione degli aggressivi chimici. In estate effettuarla nelle ore fresche della giornata.
5. Fare sempre test preventivi prima dell'uso (su una piastrella non posata), in particolare per prodotti Lappati o Levigati.
5. Pulizia stucchi epossidici, bi-componenti e reattivi

In questi casi la rimozione dei residui degli stucchi deve essere fatta immediatamente ed in modo molto accurato seguendo le indicazioni dei fabbricanti, perché questi stucchi induriscono molto rapidamente, anche in pochi minuti. Seguire attentamente le modalità di pulizia indicate dal fabbricante dello stucco utilizzato e verificarne l'efficacia (anche con un controllo!) con una prova preliminare di pulizia prima di stuccare l'intero pavimento/parete.

## 6. piastrelle antiscivolo

Le piastrelle "antislip", realizzate con superfici ruvide e/o strutturate, si puliscono ovviamente in modo più laborioso. Si consiglia perciò di effettuare la pulizia "dopo posa" in modo rapido ed accurato, utilizzando quando possibile monospazzola con dischi bianchi e beige.

## PULIZIA STRAORDINARIA

Viene effettuata per rimuovere macchie o residui particolarmente vecchi o resistenti. Prima dell'uso fare sempre test preventivi (su una piastrella non posata), in particolare su **Lappati e Levigati**. Nella tabella sotto sono indicati detersivi efficaci a seconda del tipo di macchia.

RESIDUO DA RIMUOVERE	TIPO DI DETERGENTE	NOME DETERGENTI	PRODUTTORE
grassi polvere da calpestio pulizie di fondo	polifunzionali, a base alcalina(1)	ps87	fila
		intensivreiniger	lithofin
		hmk r55	hmk
		taski r20-strip	johnsondiversey
		bonadecon / bdecon	bonasystems italia
		deterflash	geal
caffè coca-cola succhi di frutta	polifunzionali, a base alcalina(1)	coloured stain remover	faberchimica
		ps87	fila
		super deterjet	geal
vino	ossidante	candeggina	vari produttori
		oxidant candeggina	faberchimica vari produttori
depositi calcarei	a base acida (1)	viakal	procter & gamble
rustine	a base acida (1)	acido muriatico diluito	vari produttori
inchiostri pennarello	a base solvente	diluente nitro, acqua regia	vari produttori
		coloured stain remover	faberchimica
pneumatici, segni di gomma di metalli di matita	pasta abrasiva (1)	vim clorex (2)	guaber
		polishing cream (2)	faberchimica
		strong remover (3)	faberchimica
		detergum (3)	zep italia
sporco delle fughe	specifico	fuganet	fila
		fugenreiniger	lithofin

(1) Fare test preventivo su materiali Lappati e Levigati (2) Indicato per materiali Lappati e Levigati (3) Non usare su prodotti Lappati, usare con molta attenzione sui Levigati  
Salvo diversa indicazione di LEA CERAMICHE, seguire attentamente le modalità d'uso indicate sulle confezioni dai fabbricanti.

**PULIZIA QUOTIDIANA / ORDINARIA**

Utilizzare acqua calda e un panno in microfibra di buona qualità, tipo **MAGICCLEAN** di **Bonasystems Italia**. Ogni tanto, ad es. ogni 10-20 giorni a seconda dello stato della pavimentazione, utilizzare detergenti neutri molto diluiti in acqua calda, che non contengono cere o non depositano patine lucide. A fine lavaggio risciacquare sempre con acqua, utilizzando un secondo panno in microfibra di buona qualità.

TIPO DI OPERAZIONE	TIPO DI DETERGENTE	NOME DETERGENTI	PRODUTTORE
pulizie quotidiane	neutro	floor cleaner	faberchimica
		fila cleaner	fila
		pflegereiniger	lithofin
		hmk p15	hmk
		bonamain + / bmain +	bonasystems italia
		bonatitania clean / btitania clean	bonasystems italia
		belgres	geal

Salvo diversa indicazione di LEA CERAMICHE, seguire attentamente le modalità d'uso indicate sulle confezioni dai fabbricanti.

**PULIZIA DECORI**

- Utilizzare detergenti NEUTRI e diluiti.

**NON UTILIZZARE ASSOLUTAMENTE:** Ceranti e/o impregnanti - Detergenti acidi o alcalini - Paste abrasive - Spazzole o spugne abrasive.

**RIMOZIONE DI PATINE LUCIDE**

Nei normali detergenti in commercio sono a volte contenute cere o additivi lucidanti che, lavaggio dopo lavaggio, depositano sul pavimento **patine lucide**, causa di noiose alonature. Patine di questo tipo possono essere depositate anche da alcuni stucchi per le fughe. Semplici alimenti come Coca Cola, vino, acqua, etc., cadendo sul pavimento tolgono questa patina lucida e ripristinano l'**aspetto originale** più opaco delle piastrelle. In mezzo al pavimento più lucido, le zone senza cera appaiono come aloni opachi, in realtà sono le uniche parti pulite del pavimento. In questi casi bisogna:

1. Prima di tutto togliere la patina lucida da tutto il pavimento (vedi tabella seguente);
2. Poi, per le pulizie quotidiane, utilizzare detergenti neutri che non contengano né cere né patine lucidanti (vedi paragrafo precedente "pulizie quotidiane/ordinarie").

RESIDUO DA RIMUOVERE	TIPO DI DETERGENTE	NOME DETERGENTI	PRODUTTORE
patine lucide	debolmente acidulo	tile cleaner puro (*)	faberchimica

(\*) Non seguire le indicazioni sulla confezione, ma applicare il detergente puro, lasciare agire per 5-10 minuti, frizionare con tamponi morbidi (bianco, giallo) e sciacquare bene con acqua. Non utilizzare cere su gres porcellanato LEA CERAMICHE.

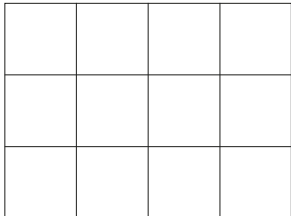
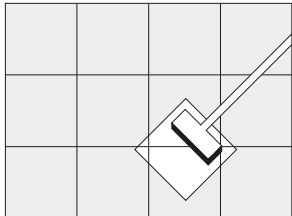
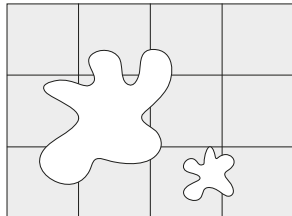
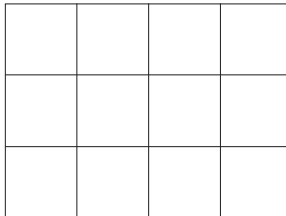
<b>1</b>		<b>2</b>		<b>3</b>		<b>4</b>	
	Pavimento originale.		Dopo pulizia con detergenti contenenti cere.		Semplici alimenti (Coca-Cola, vino, acqua...) possono togliere la patina lucida. La superficie originale è più opaca.		Rimuovere la patina con detergente (Tile Cleaner puro, Faber) ed utilizzare quotidianamente un detergente senza cere.

**MANUTENZIONI STRAORDINARIE****Protettivi per fughe**

NOME PRODOTTO	PRODUTTORE
fugaproof	fila
kf fugenschutz	lithofin

Salvo diversa indicazione di LEA CERAMICHE, seguire attentamente le modalità d'uso indicate sulle confezioni dai fabbricanti.

**Trattamenti antislip**

La resistenza allo scivolamento dei pavimenti posati (sia piastrelle smaltate che non smaltate) può essere aumentata utilizzando specifici prodotti (vedi tabella).

Prima di applicare il prodotto sul pavimento fare test preventivi su piastrelle non posate per trovare i tempi di contatto più idonei. Se da un lato tempi più lunghi aumentano il grado di grip, dall'altro tendono un po' a sbiancare i colori delle piastrelle e a renderle un pochino più sporcabili.

TIPO DI OPERAZIONE	NOME PRODOTTO	PRODUTTORE
trattamento antislip	bonagrip	bonasystems italia

**attenzione:**

1. Non usare questi trattamenti su superfici lappate né levigate; 2. Prima del trattamento contattare Servizio Clienti Lea; 3. Si consiglia di realizzare il trattamento tramite ditte specializzate.

I prodotti **LEVIGATI** possono raggiungere il grado **R9** (test DIN51130) con appositi trattamenti al laser, eseguibili solo sul materiale non posato: per questo la richiesta di R9 su Levigati deve essere specificata al momento dell'ordine all'ufficio commerciale.

Tali trattamenti al laser possono essere seguiti anche su superfici **LAPPATE** (dopo verifica Servizio Clienti LEA CERAMICHE).

Riferimenti utili pag. 424

Il manuale tecnico "pulizia e manutenzione" è disponibile sul sito internet [www.ceramichelea.com](http://www.ceramichelea.com)

# CLEANING AND MAINTENANCE INFORMATION

Make sure to do the following before cleaning any tiled surface:

1. Check the **resistance to chemical agents** of the laid tiles on the general catalogue;
  2. Make a preliminary test directly on the laid tiles by putting a detergent, to be used in contact with the tiles for a period that is equal to the period that will be used later on the site;
  3. Make sure that the detergents that are going to be used, **do not contain** hydrofluoric acid and/or any of its derivatives; these substances are distinctively known for damaging **all** ceramic products.
- Some indications for cleaning after the installation (after laying the tiles), on a daily basis, extra cleaning and to remove waxes and polish glazes or for any extra maintenance that may be required, are listed here below.

## CLEANING "AFTER THE INSTALLATION"

1. Cleaning "after the installation" helps remove residues of grout-joints, cement and lime. This is obligatory at the end of the installation, for glazed tiles and unglazed tiles.
  2. If the cleaning "after the installation" is not carried out properly or if is not carried out at all, is often a cause of marks that prevent the floor from being clean even if a good daily cleaning is performed.
  3. Whenever is possible, especially for medium to large surfaces, it is advisable to use a single-brush machine with soft disks (white or beige).
  4. cleaning cement-based grouts mixed with water.
- It is carried out with specific detergents based with buffered and diluted acids. The table below shows some of these detergents, which are easily available in the market.

FOR REMOVING THE FOLLOWING RESIDUES	TYPE OF DETERGENT	DETERGENT'S NAME	MANUFACTURER
cement-based grouts grout cement lime	buffered acid based	keranet	mapei
		cement remover	faberchimica
		deterdek	fila
		trek	kiter
		zementschleierentferner	lithofin
		hmk r63	hmk
		solvacid	geal
		bonaclean / bclean	bonasystems italia
		bonadecon / bdecon (*)	bonasystems italia

Unless otherwise indicated by LEA CERAMICHE, follow the instructions indicated on the manufacturer's package very carefully. (\*) Specific for products that are non-resistant to acids

## INSTRUCTIONS ON HOW TO CLEAN "AFTER THE INSTALLATION":

1. Clean 4-5 days after the grouting (the grout must be hardened); do not wait over 10 days. In addition to this period, the cleaning can become very laborious.
  2. Moisten the floor with water before cleaning. This way the groutings are soaked with water and the contact with detergents is reduced.
  3. Let the detergents operate for limited periods, hence rinse out with water as soon as possible.
  4. It must not be carried out if the tiled surfaces are **very hot** (i.e. exposed to the sun during very warm days); this must be avoided as the action of aggressive chemicals become very harsh. On the summer, proceed with the operation during the coolest period of the day.
  5. Make sure to always perform a precautionary test before using the product (on a tile that is not laid), especially for Lapped or Polished products.
  5. cleaning for epoxy, bi-component and reagent grouts
- In these cases the removal must be carried out immediately and carefully following the recommendations of the manufacturers, as these grouts harden very fastly, even in a few minutes. Please carefully follow the cleaning mode specified by the manufacturer of the grout used; verify its effectiveness (backlight also) with a preliminary cleaning test before grouting the entire floor/wall.
6. antislip tiles
- "Antislip" tiles that are made with rough and/or textured surfaces must be cleaned very laboriously. Therefore, it is advisable to clean "after the installation", quickly and thoroughly, using a single-brush machine with disks white and beige.

## EXTRAORDINARY CLEANING

This procedure is carried out to remove stains or residues that are particularly old or tough. Make sure to always perform a precautionary test before using the product (on a tile that is not laid), especially for **Lapped** or **Polished** products.

The table shown below indicates the detergents that are effective according to the type of stains.

FOR REMOVING THE FOLLOWING RESIDUES	TYPE OF DETERGENT	DETERGENT'S NAME	MANUFACTURER
grease dust footmarks base cleaning	multipurpose, alkaline-based (1)	ps87	fila
		intensivreiniger	lithofin
		hmk r55	hmk
		taski r20-strip	johnsondiversey
		bonadecon / bdecon	bonasystems italia
		deterflash	geal
coffee coke fruit juice	multipurpose, alkaline-based (1)	coloured stain remover	faberchimica
		ps87	fila
		super deterjet	geal
wine	oxidizing agent	candeggina	vari produttori
		oxidant candeggina	faberchimica vari produttori
calcareous deposits	acid-based (1)	viakal	procter & gamble
rust	acid-based (1)	acido muriatico diluito	vari produttori
inks felt-tipped pen	solvent-based	diluyente nitro, acqua ragia	vari produttori
		coloured stain remover	faberchimica
pneumatic stains from rubber metals or pencils	abrasive paste (1)	vim clorex (2)	guaber
		polishing cream (2)	faberchimica
		strong remover (3)	faberchimica
		detergum (3)	zep italia
		fuganet	fila
tile joint stains	specific	fuganet	fila
		fugenreiniger	lithofin

(1) Make precautionary test on Lapped or Polished materials. (2) Suitable for Lapped or Polished materials. (3) Do not use it on Lapped; use it with the utmost caution on Polished products. Unless otherwise indicated by LEA CERAMICHE, follow the usage instructions indicated on the manufacturer's package very carefully.



## DAILY / STANDARD CLEANING

Use warm water and a good quality microfibre cloth, such as MAGICCLEAN by **Bonasystems Italy**. Every now and again, e.g. every 10-20 days depending on the state of the flooring, use neutral detergents diluted with hot water, that are wax-free, and do not deposit glossy stains. When the cleaning process is finished always rinse with water, using a second good quality microfibre cloth.

TYPE OF OPERATION	TYPE OF DETERGENT	DETERGENT'S NAME	MANUFACTURER
clean on a daily basis	neutral	floor cleaner	faberchimica
		fila cleaner	fila
		pflgereiniger	lithofin
		hmk p15	hmk
		bonamain + / bmain +	bonasystems italia
		bonatitania clean / btitania clean	bonasystems italia
		belgres	geal

Unless otherwise indicated by LEA CERAMICHE, follow the instructions indicated on the manufacturer's package very carefully.

## CLEANING DECORATIONS

- Use NEUTRAL, diluted detergents

**NEVER USE:** Waxing and impregnating agents - Acid or alkaline detergents - Abrasive pastes - Abrasive brushes or sponges.

## REMOVING GLOSSY GLAZE

Standard detergents that are available in the market sometimes contain waxes or polish additives that, wash after wash, deposit **glossy glaze** on the floor and causes annoying marks. These types of glazes can also settle on some joint grouts.

When simply types of foods such as Coke, wine, water, etc., fall on the floor, they remove this type of glossy glaze and restore the **original appearance** of the tiles (a more opaque look).

In the middle of the shinier floor, the areas without wax appear as opaque marks, but they are actually the only clean parts of the floor. In these cases, the following must be done:

1. First of all, remove the glossy glaze from the entire floor (see table below);
2. Then, for daily cleaning, use neutral detergents that do not contain wax or polishing glaze (see the previous paragraph: "daily/standard cleaning").

RESIDUES TO BE REMOVED	TYPE OF DETERGENT	DETERGENT'S NAME	MANUFACTURER
glossy glaze	weak acidulous	tile cleaner pure (*)	faberchimica

(\*) Do not follow the instructions on the package, just apply the pure detergent, leave it on for 5-10 minutes, rub it with soft pads (white, yellow) and rinse it thoroughly with water.

**Do not use wax** on LEA CERAMICHE porcelain stoneware.

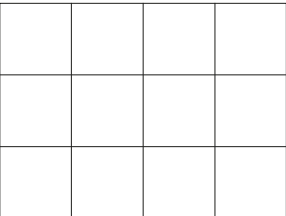
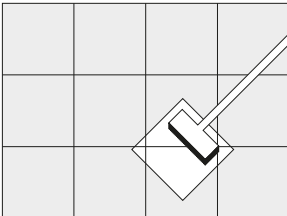
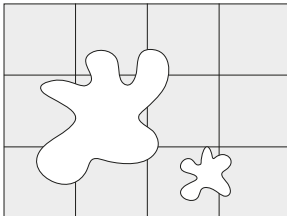
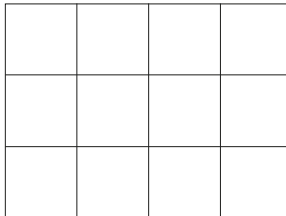
<b>1</b>		<b>2</b>		<b>3</b>		<b>4</b>	
	Original floor.		After cleaning detergents containing waxes.		Simple foodstuffs (Coca-Cola, wine, water etc) can remove the bright patina. The original surface is more matt.		Remove the patina with detergent (Faber tile cleaner, used neat), and use detergent without waxes for everyday cleaning.

## SPECIAL MAINTENANCE

### Stain-resistant products for joints

PRODUCT NAME	MANUFACTURER
fugaproof	fila
kf fugenschutz	lithofin

Unless otherwise indicated by LEA CERAMICHE, follow the instructions indicated on the manufacturer's package very carefully.

### Antislip treatments

The slip resistance of floors laid with glazed tiles or non-glazed tiles can be increased by using specific products (see table).

Before applying the product make a precautionary test on a tile that is not laid in order to find the most suitable contact time. If, on the one hand, the longest period increases the griping grade, on the other, it will tend to whiten the colours of the tiles a little and make it a little easier to stain.

TYPE OF OPERATION	PRODUCT NAME	MANUFACTURER
antislip treatment	bonagrip	bonasystems italia

#### caution:

1. Do not use these treatments on Lapped or Polished surfaces; 2. Before the doing the treatment contact Lea's Customer Service; 3. It is advisable to carry out the treatments through specialized companies.

**POLISHED** products can reach a grade of **R9** (test DIN51130) with special laser treatments that may be carried out only on materials that have not been laid: for this reason the request for R9 on Polished products must be specified at the time of the order in the sales department. Such laser treatments can be also be carried out on **LAPPED** surfaces (after making a verification with LEA CERAMICHE Customer Service).

Useful contacts pag. 424

The manual "cleaning and maintenance" is available on the website [www.ceramichelea.com](http://www.ceramichelea.com)

# INFORMATIONS SUR LE NETTOYAGE ET L'ENTRETIEN

Avant de nettoyer une surface carrelée, il est préférable de:

1. Vérifier la **résistance chimique** des carreaux posés sur le catalogue général;
2. Faire un test avant emploi en versant le nettoyant directement sur les carreaux installés et en le laissant agir aussi longtemps que la durée prévue sur le chantier;
3. S'assurer que les nettoyants **ne contiennent** ni acide fluorhydrique ni aucun de ses dérivés, car ces substances particulières entament tous les produits céramiques.

Veillez trouver ci-après quelques instructions pour bien effectuer les nettoyages de fin de chantier (« après pose »), quotidiens, extraordinaires, pour éliminer les cires et les additifs de cirage et pour réaliser toute opération d'entretien extraordinaire.

## NETTOYAGE « APRÈS POSE »

1. Le nettoyage « après pose » sert à enlever les résidus de mortier, de ciment, de chaux et de ciment-joint. Il est obligatoire à la fin du chantier, aussi bien pour les carreaux émaillés que pour les carreaux non émaillés.
2. Un mauvais nettoyage « après pose », voire même l'absence de nettoyage, entraîne souvent la formation d'auroles qui compromettent la propreté du revêtement de sol, même après un bon nettoyage quotidien.
3. Chaque fois que possible, notamment pour les surfaces moyennes/grandes, il est recommandé d'avoir recours à une monobrosse munie des disques souples (blancs ou beige).
4. Nettoyage ciments-joints mélangés avec de l'eau  
Nettoyage avec des nettoyants spéciaux à base d'acides tamponnés et dilués. Veuillez trouver dans le tableau ci-après quelques noms de produits facilement trouvables dans le commerce.

RÉSIDU À ENLEVER	TYPE DE NETTOYANT	NOM DES NETTOYANTS	FABRICANT
ciments-joints ciment chaux	à base d'acides tamponnés	keranet	mapei
		cement remover	faberchimica
		deterdek	fila
		trek	kiter
		zementschleierentferner	lithofin
		hmk r63	hmk
		solvacid	geal
		bonaclean / bclean	bonasystems italia
		bonadecon / bdecon (*)	bonasystems italia

Sauf indication contraire de LEA CERAMICHE, suivre avec soin le mode d'emploi signalé par le fabricant sur l'emballage. (\*) Spécifique pour produits qui ne sont pas résistants aux acides

## INSTRUCTIONS DE NETTOYAGE «APRÈS POSE»:

1. Nettoyer 4-5 jours après l'exécution des joints (le mortier doit durcir) et avant 10 jours maximum. Après ce délai, le nettoyage peut demander beaucoup plus d'efforts.
2. Mouiller le revêtement de sol avant les opérations de nettoyage. Ainsi l'eau imprègne les joints et atténue le contact avec les nettoyants.
3. Laisser agir les nettoyants peu de temps et bien rincer à l'eau dès que possible.
4. Ne pas faire le nettoyage si les surfaces carrelées sont très chaudes (par ex. exposées au soleil pendant les mois les plus chauds), car la chaleur renforce l'action agressive des produits chimiques. En été, il doit se faire aux heures fraîches de la journée.
5. Faire toujours des tests avant emploi (sur un carreau non posé), notamment sur les produits Rodés ou Polis.
5. Nettoyage des joints epoxy, bi-composant et réactif  
Nettoyer immédiatement les résidus de manière soignée en se conformant aux indications fournies par le fabricant car ce type de coulis durcit rapidement, même en quelques minutes. Suivez attentivement les indications de nettoyage indiqué par le fabricant de joint utilisé et vérifiez son efficacité (même rétroéclairage) avec un nettoyage préventif avant de jointoyer la totalité du sol / mur.
6. Carreaux antidérapants

Les carreaux « antislip » à base de structures rugueuses et/ou structurées se nettoient évidemment moins facilement. Il est dès lors recommandé d'effectuer le nettoyage « après pose » de façon rapide et minutieuse et d'utiliser, si possible, une monobrosse à disques blancs ou beige.

## NETTOYAGE EXTRAORDINAIRE

Il sert à éliminer les taches ou les résidus particulièrement anciens ou tenaces. Faire toujours des tests avant emploi (sur un carreau non posé), notamment sur les produits **Rodés** et **Polis**. Veuillez trouver dans le tableau ci-après des nettoyants efficaces selon le type de tache.

RÉSIDU À ENLEVER	TYPE DE NETTOYANT	NOM DES NETTOYANTS	FABRICANT
graisses dépôts de poussières laissées par le piétinement grands nettoyages	alcalins universels (1)	ps87	fila
		intensivreiniger	lithofin
		hmk r55	hmk
		taski r20-strip	johnsondiversey
		bonadecon / bdecon	bonasystems italia
		deterflash	geal
café Coca-Cola jus de fruits	alcalins universels (1)	coloured stain remover	faberchimica
		ps87	fila
		super deterjet	geal
		candeggina	vari produttori
vin	oxydant	oxidant candeggina	faberchimica vari produttori
dépôts calcaires	acide (1)	viakal	procter & gamble
rouille	acide (1)	acido muriatico diluito	vari produttori
encres feutre	à base de solvant	diluyente nitro, acqua ragia	vari produttori
		coloured stain remover	faberchimica
pneus traces de caoutchouc de métaux de crayon	pâte abrasive (1)	vim clorex (2)	guaber
		polishing cream (2)	faberchimica
		strong remover (3)	faberchimica
		detergum (3)	zep italia
saleté des joints	spécifique	fuganet	fila
		fugenreiniger	lithofin

(1) Faire des tests avant emploi sur les produits Rodés et Polis. (2) Recommandé pour les produits Rodés et Polis. (3) Ne pas utiliser sur les produits Rodés, utiliser sur les produits polis en faisant très attention. Sauf indication contraire de LEA CERAMICHE, suivre avec soin le mode d'emploi signalé par le fabricant sur l'emballage.

## NETTOYAGE QUOTIDIEN / ORDINAIRE

Utiliser de l'eau chaude et un chiffon en microfibre de bonne qualité, type MAGICCLEAN de **Bonasystems Italia**. De temps en temps, tous les 10-20 jours par ex., et selon l'état du sol, utiliser des détergents neutres très dilués dans de l'eau chaude qui ne contiennent pas de cires et ne laissent pas de tâches brillantes. En fin de lavage, rincer toujours à l'eau et à l'aide d'un chiffon en microfibre de bonne qualité.

TYPE D'OPERATION	TYPE DE NETTOYAGE	NOM DES NETTOYANTS	FABRICANT
nettoyages quotidiens	neutre	floor cleaner	faberchimica
		fila cleaner	fila
		pfliegereiniger	lithofin
		hmk p15	hmk
		bonamain + / bmain +	bonasystems italia
		bonatitania clean / btitania clean	bonasystems italia
		belgres	geal

Sauf indication contraire de LEA CERAMICHE, suivre avec soin le mode d'emploi signalé par le fabricant sur l'emballage.

## NETTOYAGE DÉCORS

- utiliser des détergents NEUTRES et dilués. **NE SURTOUT PAS UTILISER:** Agents cirants et/ou agents d'imprégnation - Des détergents acides ou alcalins - Des produits abrasifs - Des brosses ou des éponges abrasives.

## ÉLIMINATION DES FILMS BRILLANTS

Les nettoyeurs ordinaires disponibles dans le commerce contiennent souvent des cires ou des additifs de cirage qui, lavage après lavage, déposent sur le revêtement de sol des **films brillants** qui entraînent la formation d'auréoles difficiles à éliminer. Des films de ce genre peuvent aussi être occasionnés par certains mortiers. Si des simples boissons, comme le Coca-Cola, le vin, l'eau, etc., sont renversées sur le sol, ce film brillant part et les carreaux reprennent leur **aspect original** plus mat. À côté des carreaux plus brillants, les zones sans cire ont l'air d'être des sortes d'auréoles mates, alors qu'en fait, ce sont les seules parties propres du revêtement de sol. Dans ce cas, il faut :

- avant toute chose, éliminer le film brillant sur l'ensemble du revêtement de sol (voir tableau ci-après) ;
- ensuite, pour les nettoyages quotidiens, utiliser des nettoyeurs neutres qui ne contiennent ni cire ni additif de cirage (voir paragraphe précédent « nettoyages quotidiens/ordinaires »).

RÉSIDU À ENLEVER	TYPE DE NETTOYANT	NOM DES NETTOYANTS	FABRICANT
patine lucide	debolmente acidulo	tile cleaner puro (*)	faberchimica

(\*) Ne pas suivre le mode d'emploi signalé sur l'emballage, mais utiliser le nettoyeur pur, laisser agir 5-10 minutes, frotter avec des disques tampons doux (blanc, jaune) et bien rincer à l'eau. **Nes pas utiliser de cires** sur le grès cérame LEA CERAMICHE.

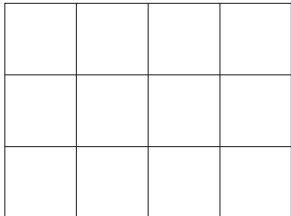
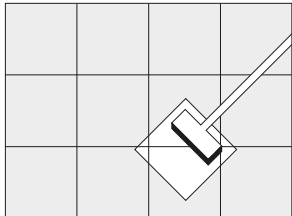
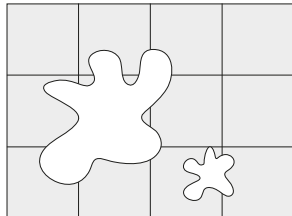
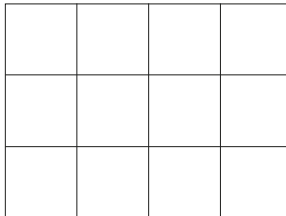
<b>1</b>		<b>2</b>		<b>3</b>		<b>4</b>	
	Sol original.		Après un nettoyage avec détergents contenant de la cire.		Certains aliments (Coca-Cola, vin, eau, etc.) peuvent enlever la patine brillante. La surface originelle est plus opaque.		Retirer la patine à l'aide d'un détergent (Tile Cleaner pur de Faber) et utiliser chaque jour un détergent sans cire.

## ENTRETIENS EXTRAORDINAIRES

### Protection joints

NOM DU PRODUIT	FABRICANT
fugaproof	fila
kf fugenschutz	lithofin

Sauf indication contraire de LEA CERAMICHE, suivre avec soin le mode d'emploi signalé par le fabricant sur l'emballage.

### Traitements antidérapantes

La résistance au glissement des carrelages posés (aussi bien des carreaux émaillés que des carreaux non émaillés) peut être améliorée avec des produits spécifiques (voir tableau). Avant d'appliquer le produit sur le revêtement de sol, faire toujours des tests sur les carreaux non posés pour déterminer les temps de pose plus indiqués. Si d'un côté, les longs temps de pose augmentent le coefficient de frottement, de l'autre, ils ont tendance à décolorer un peu les carreaux et à les salir plus vite.

TYPE D'OPÉRATION	NOM DU PRODUIT	FABRICANT
traitement antidérapante	bonagrip	bonasystems italia

#### attention:

1. Ne pas faire ces traitements sur les surfaces Rodées ou Polies ; 2. Avant le traitement, contacter le Service Clients Lea ; 3. Il est recommandé de confier le traitement à des entreprises spécialisées.

Les produits **POLIS** peuvent atteindre un niveau d'adhérence **R9** (essai DIN 51130) par le biais de traitements laser ; ceux-ci ne peuvent être effectués que sur les produits non posés. Pour les carreaux Polis, le client est donc tenu de spécifier le niveau R9 au service commercial lors de la commande. Ces traitements laser peuvent aussi être effectués sur les surfaces **RODÉES** (après vérification auprès du Service Clients LEA CERAMICHE).

Quelques noms utiles pag. 424

Le manuel technique « entretien et maintenance » est disponible sur le site internet [www.ceramichlea.it](http://www.ceramichlea.it)

# INFORMATIONEN ZUR REINIGUNG UND PFLEGE

Vor der Reinigung einer gefliesten Fläche wird folgendes empfohlen:

1. Im Hauptkatalog die **Chemikalienbeständigkeit** der verlegten Fliesen prüfen;
2. Einen Vortest direkt auf den verlegten Fliesen vornehmen, indem das zu verwendende Reinigungsmittel über den gleichen Zeitraum wie in der Baustelle mit den Fliesen in Kontakt gebracht wird;
3. Sicherstellen, dass die zu verwendenden Reinigungsmittel **keine** Fluorwasserstoffsäure und/oder ihre Derivate enthalten, da diese Substanzen durch ihre Besonderheit **alle** keramischen Produkte angreifen.

Es folgen einige Angaben zur täglichen, außergewöhnlichen Reinigung am Ende der Bauarbeiten („nach dem Verlegen“), um Wachs und glänzende Schichten zu entfernen und um eventuelle besondere Wartung auszuführen.

## REINIGUNG „NACH DEM VERLEGEN“

1. Die Reinigung „nach dem Verlegen“ dient zur Entfernung der Spachtelrückstände, Zementrückstände und Kalkrückstände. Sie ist am Ende der Bauarbeiten für die glasierten und unglasierten Fliesen obligatorisch.
2. Eine schlecht ausgeführte oder eventuell gar nicht ausgeführte Reinigung „nach dem Verlegen“ ist oft die Ursache von Schatten, die trotz einer täglichen Reinigung die Ursache eines nicht sauberen Bodens sind.
3. Wenn möglich – vor allem bei mittel-großen Oberflächen – empfehlen wir die Anwendung eines Einbürstengeräts mit passenden Scheiben weich (weiß oder beige).
4. reinigung von mit wasser gemischten mörtel  
Diese wird mit speziellen Reinigungsmitteln mit gepufferten und verdünnten Säuren ausgeführt. Einige dieser, die im Handel leicht erhältlich sind, sind in der folgenden Tabelle aufgeführt.

ZU ENTFERNENDER REST	REINIGUNGSMITTEL	NAME REINIGUNGSMITTEL	HERSTELLER
Mörtel	Mit gepufferten Säuren	keranet	mapei
Zementschlamm		cement remover	faberchimica
Zement		deterdek	fila
Kalk		trek	kiter
		zementschleierentferner	lithofin
		hmk r63	hmk
		solvacid	geal
		bonaclean / bclean	bonasystems italia
		bonadecon / bdecon (*)	bonasystems italia

Außer bei anders lautenden Angaben von LEA CERAMICHE, werden die Gebrauchsanweisungen der Produkthersteller befolgt. (\*) Für nicht säurebeständige Produkte geeignet

## ANLEITUNGEN FÜR DIE REINIGUNG „NACH DEM VERLEGEN“:

1. Die Reinigung 4-5 Tage nach der Verlegung (die Fugenmasse muss aushärten) und nicht nach 10 Tagen ausführen. Über diesen Zeitraum hinaus kann die Reinigung sehr schwierig werden.
2. Den Boden vor der Reinigung mit Wasser benetzen. Auf diese Weise werden die Verfugungen mit Wasser benetzt und der Kontakt mit den Reinigungsmitteln reduziert.
3. Die Reinigungsmittel über eine begrenzte Zeit einwirken lassen und sobald wie möglich mit Wasser spülen.
4. Die Reinigung darf nicht ausgeführt werden, wenn die gefliesten Flächen sehr heiß sind (z.B. im Sommer der Sonne ausgesetzt), da die Wirkung der chemischen Substanzen aggressiver ist. Im Sommer wird sie in den kühlen Stunden des Tags ausgeführt.
5. Vor der Anwendung immer Tests vornehmen (auf einer nicht verlegten Fliese), insbesondere bei geläpften oder polierten Produkten.
5. Reinigung von epoxi-, bi-komponent und aktiven spachtelmassen  
In diesen Fällen müssen die Stuckrückstände sofort und sehr sorgfältig unter Beachtung der Angaben des Herstellers erfolgen, weil diese Stücke u.U. sehr schnell in wenigen Minuten härten. Die angegebene Reinigungshinweis vom Hersteller der verwendete Fugenmasse sorgfältig befolgen. Vor dem Verfugen des gesamten Belag (Boden u/o Wand), die Wirkung der Reinigungsempfehlung (auch im Gegenlicht!) mit einem Vor-Test Reinigung überprüfen.

## 6. Rutschfeste fliesen

Aufgrund ihrer Beschaffenheit sind die rutschfesten, rauen oder strukturierten Oberflächen etwas schwieriger zu reinigen. Aus diesem Grunde ist die Reinigung sehr wichtig. Für eine schnellere Reinigung wird der Einsatz einer Einscheibenmaschine mit einer weissen oder beige Scheibe empfohlen.

## SONDERREINIGUNG

Sie wird ausgeführt, um besonders alte oder hartnäckige Flecken oder Reste zu entfernen. Vor der Anwendung immer Tests vornehmen (auf einer nicht verlegten Fliese), insbesondere bei **geläpften** und **polierten** Fliesen. In der unten aufgeführten Tabelle sind wirksame Reinigungsmittel je nach Fleckenart angegeben.

ZU ENTFERNENDER REST	ART DES REINIGUNGSMITTELS	NAME REINIGUNGSMITTEL	HERSTELLER
Fette Trittsaub Grundreinigung	Polyfunktionell, mit Alkalibasis (1)	ps87	fila
		intensivreiniger	lithofin
		hmk r55	hmk
		taski r20-strip	johnsondiversey
		bonadecon / bdecon	bonasystems italia
		deterflash	geal
Kaffee Coca Cola Obstsäfte	Polyfunktionell, mit Alkalibasis (1)	coloured stain remover	faberchimica
		ps87	fila
		super deterjet	geal
Wein	Oxydierend	candeggina	vari produttori
Kalkrückstände	Mit Säurebasis (1)	oxidant candeggina	faberchimica vari produttori
		viakal	procter & gamble
Rost	Mit Säurebasis (1)	acido muriatico diluito	vari produttori
Tinten Filzstift	Mit Lösungsmittel	diluyente nitro, acqua ragia	vari produttori
		coloured stain remover	faberchimica
Reifen Gummiflecken Metall Bleistift	scheuermittel (1)	vim clorex (2)	guaber
		polishing cream (2)	faberchimica
		strong remover (3)	faberchimica
		detergum (3)	zep italia
Fugenschmutz	Spezifisch	fuganet	fila
		fugenreiniger	lithofin

(1) Vortesten auf geläpften und polierten Materialien. (2) Für geläppte und polierte Materialien. (3) Nicht auf geläpften Produkten verwenden, sehr vorsichtig auf polierten Materialien verwenden.

Außer bei anders lautenden Angaben von LEA CERAMICHE, die von den Herstellern angegebenen Gebrauchsanweisungen befolgen.

## TÄGLICHE / REGELMÄSSIGE REINIGUNG

Warmes Wasser und ein hochwertiges Mikrofasertuch vom Typ MAGICCLEAN von **Bonasystems Italia** verwenden. Ab und zu, zum Beispiel alle 10-20 Tage, je nach Zustand des Fußbodenbelags, neutrale in warmen Wasser verdünnte Reinigungsmittel verwenden, die wachsfrei sind und keine glänzenden Schmierfilme hinterlassen. Nach dem Reinigen immer mit Wasser nachspülen und dafür ein zweites hochwertiges Mikrofasertuch verwenden.

VORGANGSART	ART DES REINIGUNGSMITTELS	NAME REINIGUNGSMITTEL	HERSTELLER
Tägliche Reinigung	Neutral	floor cleaner	faberchimica
		fila cleaner	fila
		pflegereiniger	lithofin
		hmk p15	hmk
		bonamain + / bmain +	bonasystems italia
		bonatitania clean / btitania clean	bonasystems italia
		belgres	geal

Außer bei anders lautender Angabe durch LEA CERAMICHE, die Gebrauchsanleitungen der Hersteller befolgen.

## REINIGUNG DES FLIESENDEKORS

- Verwenden Sie ausschließlich NEUTRALE und verdünnte Reinigungsmittel. **VERWENDEN SIE AUF KEINEN FALL:** Wachs- und/oder Imprägniermittel - Ätzende oder alkalische Reinigungsmittel - Scheuerpasten- und Pulver - Grobe Bürsten oder abrasive Schwämme.

## ENTFERNEN VON GLÄNZENDEN SCHICHTEN

In den normalen handelsüblichen Reinigungsmitteln sind manchmal Wachse oder glänzende Zusätze enthalten, die nach jeder Reinigung glänzende Schichten auf dem Boden hinterlassen, die hartnäckige Streifen verursachen. Schichten dieser Art können auch von einiger Fugenmassen hinterlassen werden. Einfache Lebensmittel wie Coca Cola, Wein, Wasser usw. entfernen durch Fallen auf den Boden diese glänzende Schicht und bringen den matten **Originalzustand** der Fliesen wieder zum Erscheinen. Auf dem glänzenden Teil des Bodens erscheinen die Bereiche ohne Wachs als matte Schatten, eigentlich handelt es sich um die einzigen sauberen Bereiche des Bodens. In diesen Fällen muss man:

1. Zuerst die glänzende Schicht vom ganzen Boden entfernen (siehe folgende Tabelle);
2. Dann zur täglichen Reinigung neutrale Reinigungsmittel verwenden, die keine Wachse oder glänzende Zusätze enthalten (siehe vorheriger Abschnitt „tägliche/regelmäßige Reinigung“).

ZU ENTFERNENDER REST	ART DES REINIGUNGSMITTELS	NAME REINIGUNGSMITTEL	HERSTELLER
Glänzende Schichten	Leicht sauer	tile cleaner pur (*)	faberchimica

(\*) Die Angaben auf der Verpackung nicht befolgen, sondern das Reinigungsmittel pur anwenden, 5-10 Minuten einwirken lassen, mit weichen Kissen abreiben (weiß, gelb) und gut mit Wasser abspülen. **Keine Wachse** auf Feinsteinzeug von LEA CERAMICHE verwenden.

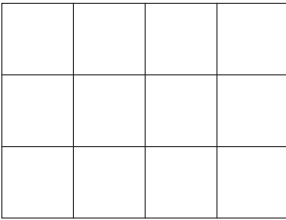
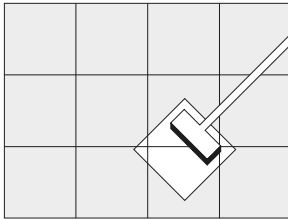
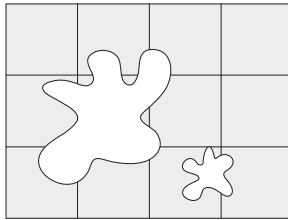
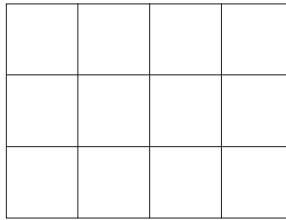
<b>1</b>  Originalfußboden.	<b>2</b>  Nach der Reinigung mit wachshaltigen Reinigungsmitteln.	<b>3</b>  Normale Lebensmittel (Coca-Cola, Wein, Wasser usw..) können die glänzende Patina entfernen. Die Originaloberfläche ist matter.	<b>4</b>  Die Patina sollte mit Reinigungsmittel entfernt werden (Tile cleaner pur von Faber) und für die tägliche Reinigung sollte ein wachsfreies Reinigungsmittel verwendet werden.
--	--	--	---

## BESONDERE WARTUNG

### fugenschutzmittel

PRODUKTNAME	HERSTELLER
fugaproof	fila
kf fugenschutz	lithofin

Außer bei anders lautender Angabe der LEA CERAMICHE die Gebrauchsanleitungen der Hersteller befolgen.

### rutschfeste behandlung

Die Rutschfestigkeit der verlegten Böden (glasierte sowie unglasierte Fliesen) kann durch Anwendung spezifischer Produkte erhöht werden (siehe Tabelle). Bevor das Produkt auf dem Boden aufgetragen wird, werden Vortests auf nicht verlegten Fliesen vorgenommen, um die geeignete Kontaktzeit zu finden. Wenn längere Zeiten auf der einen Seite die Rutschfestigkeit erhöhen, neigen sie auf der anderen Seite dazu, die Farben der Fliesen zu bleichen und sie etwas schmutzempfindlicher zu machen.

VORGANG	PRODUKTNAME	HERSTELLER
rutschfestigkeits-Behandlung	bonagrip	bonasystems italia

### Achtung:

1. Diese Behandlungen nicht auf geläppten oder polierten Oberflächen verwenden; 2. Vor der Behandlung den Kundenservice Lea fragen; 3. Wir empfehlen, die Behandlung durch spezialisierte Firmen auszuführen

Die **POLIERTEN** Produkte können den Grad **R9** (Test DIN51130) mit geeigneten Laserbehandlungen erreichen, die nur bei nicht verlegtem Material ausgeführt werden können: Somit muss die Anforderung des Grads R9 für polierte Produkte im Auftrag an die Verkaufsabteilung angegeben werden. Diese Laserbehandlungen können auch auf **GELÄPPTEN** Oberflächen ausgeführt werden (nach der Prüfung des Kundenservice von LEA CERAMICHE).

### Nützliche adressen pag. 424

Das technische Handbuch "Reinigung und Verbrauch" finden Sie jetzt auf unsere Web Site [www.ceramichelea.com](http://www.ceramichelea.com)

## RIFERIMENTI UTILI

### USEFUL CONTACTS

### QUELQUES NOMS UTILES

### NÜTZLICHE ADRESSEN

#### **MAPEI SPA,**

via Cafiero 22, 20158 Milano – ITALY  
Tel. +39 02 37673 – [www.mapei.it](http://www.mapei.it)

#### **FABERCHIMICA SRL,**

via G. Ceresani 10 – località Campo d'Olmo 60044 Fabriano (AN) – ITALY  
Tel. +39 0732 627178 – [www.faberchimica.com](http://www.faberchimica.com)

#### **FILA INDUSTRIA CHIMICA SPA,**

via Garibaldi 32, 35018 S. Martino dei Lupari (PD) - ITALY  
Tel. +39 049 9467300 – [www.filachim.it](http://www.filachim.it)

#### **ZEP ITALIA SRL,**

via Nettunese Km 25,000 – 04011 Aprilia (LT) – ITALY  
Tel. +39 06 926691 – [www.zepitalia.it](http://www.zepitalia.it)

#### **JOHNSONDIVERSEY,**

via Meucci, 40 – 20128 Milano - ITALY  
Tel. +39 0373 2051 – [www.johnsondiverse.com](http://www.johnsondiverse.com)

#### **KITER SRL,**

via Assiano 7/B – 20019 Settimo Milanese (MI) – ITALY  
Tel. +39 02 3285220 – [www.kiter.it](http://www.kiter.it)

#### **GEAL SRL,**

via Settola 121 - 51031 Agliana (Pistoia) - ITALY  
Tel. +39 0574 750365 - [www.geal-gres.it](http://www.geal-gres.it)

#### **FEDERCHEMICALS SRL,**

via Borsi 2 - 25100 Brescia - ITALY  
Tel. +39 030 3385578 - [www.federchemicals.it](http://www.federchemicals.it)

#### **LITHOFIN-PRODUCTE GMBH,**

Postfach 1134, D-73236 Wendlingen (D)  
Service – Tel. 0049 07024/940320 – [www.lithofin.de](http://www.lithofin.de)  
Vertrieb für Österreich: CT-Austria Ges.m.b.H. A-1230 Wien Tel. 0043 01 8673434

#### **HMK - MÖLLER-CHEMIE BENELUX GMBH**

– Linge 4 NL-2105 WB Heemstede (NL)  
Tel. 0031 0252-220222 – [www.moellerchemie.de](http://www.moellerchemie.de)

#### **BONASYSTEMS ITALIA SRL,**

via Borgo Santa Chiara 29 - 30020 Torre di Mosto (Venezia) - ITALY  
Tel. +39 0421 325691 - [www.bonasystemsitalia.it](http://www.bonasystemsitalia.it)

# codici prodotto e imballi

PRODUCT CODES AND PACKING - CODES PRODUITS ET EMBALLAGE - PRODUKTCODES UND VERPACKUNG

# LEGENDA CODICI PRODOTTO

LEGEND PRODUCT CODES

LÉGENDE CODES PRODUITS

LEGEND PRODUKTCODES

## ABSOLUTE

**FONDI** plain tiles / fonds / Unifliesen

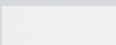
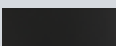



		100x100cm 39"x39"		100x300cm* 39"x118"	
		slimtech 5plus		slimtech 5plus	
				slimtech 5mm**	
<b>Total white</b>		LEV	LSCABX0	LSAABX0	
		SAT	LSCAB00	LSAAB00	
<b>Total black</b>		LEV	LSCABX1	LSAABX1	
		SAT	LSCAB10	LSAAB10	

**IMBALLI** packing / emballage / Verpackung





ARTICOLO	SCATOLA				PALLET			
	cm	inch	pz.	mq	kg	scat.	mq	kg
fondo 5plus	100x300	39"x118"	1	3,00	34,5	13 pz/pl	39,0	448,5
fondo 5plus	100x100	39"x39"	2	2,00	23,0	25	50,0	575,0

## BASALTINA STONE PROJECT

**FONDI** plain tiles / fonds / Unifliesen

		4,9x100cm 2"x39"	50x100cm 19 1/2"x39"	100x100cm 39"x39"	100x300cm* 39"x118"
		slimtech 3plus	slimtech 3plus	slimtech 3plus	slimtech 3plus
<b>Sabbia</b>		LSEBS05	LSBBS05	LSCBS05	LSABS05
<b>Naturale</b>		LSEBS15	LSBBS15	LSCBS15	LSABS15
<b>Stuccata</b>		LSEBS25	LSBBS25	LSCBS25	LSABS25
<b>Lappata</b>		LSEBS35	LSBBS35	LSCBS35	LSABS35

**MOSAICI** mosaics / mosaïques / Mosaik

	MOSAICO QUADRO	MOSAICO MATTONE	MOSAICO STRISCIA	MOSAICO LISTELLO	MOSAICO INOX	MOSAICO SATIN	MOSAICO PEARL	MOSAICO METAL	MOSAICO GLITTER
	25x25cm 10"x10"	25x25cm 10"x10"	25x50cm 10"x19 1/2"	25x50cm 10"x19 1/2"	25x25cm 10"x10"	25x25cm 10"x10"	25x25cm 10"x10"	50x100cm 19 1/2"x39"	50x100cm 19 1/2"x39"
	slimtech 3plus	slimtech 3plus	slimtech 3plus	slimtech 3plus	slimtech 3plus	slimtech 3plus	slimtech 3plus	slimtech 3mm	slimtech 3mm
<b>Sabbia</b>		LS9BS00	LS9BS10	LS9BS20	LS9BS30	LS9BS05	LS9BS15	-	LS9BS35
<b>Naturale</b>		LS9BS01	LS9BS11	LS9BS21	LS9BS31	LS9BS06	LS9BS16	-	LS9BS37
<b>Stuccata</b>		LS9BS02	LS9BS12	LS9BS22	LS9BS32	LS9BS07	LS9BS17	-	LS9BS36
<b>Lappata</b>		LS9BS03	LS9BS13	LS9BS23	LS9BS33	LS9BS08	LS9BS18	LS9BS38	-



# SLIMTECH

## IMBALLI packing / emballage / Verpackung

ARTICOLO	SCATOLA				PALLET			
	cm	inch	pz.	mq	kg	scat.	mq	kg
fondo 3plus	100x300	39"x118"	1	3,00	25,4	20 pz/pl	60,0	507,0
fondo 3plus	100x100	39"x39"	3	3,00	24,1	25	75,0	602,5
fondo 3plus	50x100	19 <sup>1/2</sup> "x39"	5	2,50	20,0	32	80,0	640,0
fondo 3plus	4,9x100	2"x39"	10	0,49	4,2	39	19,1	163,8
mosaico metal	50x100	19 <sup>1/2</sup> "x39"	2	1,00	9,9	25	25,0	247,6
mosaico striscia	25x50	10"x19 <sup>1/2</sup> "	10	1,25	6,9	60	75,0	414,0
mosaico listello	25x50	10"x19 <sup>1/2</sup> "	10	1,25	6,9	60	75,0	414,0
mosaico inox	25x25	10"x10"	10	0,63	4,6	60	37,5	276,0
mosaico satin	25x25	10"x10"	10	0,63	4,6	60	37,5	276,0
mosaico pearl	25x25	10"x10"	10	0,63	4,6	60	37,5	276,0
mosaico quadro	25x25	10"x10"	10	0,63	4,6	60	37,5	276,0
mosaico mattone	25x25	10"x10"	10	0,63	4,6	60	37,5	276,0

## GOUACHE.10 and LIBECCIO design Diego Grandi

### FONDI plain tiles / fonds / Unifliesen

### DECORI decors / decors / Dekore

	LIBECCIO				LIBECCIO 15,4x22,3cm 6 <sup>1/8</sup> "x8 <sup>3/4</sup> "
	4,9x100cm 2"x39"	50x100cm 19 <sup>1/2</sup> "x39"	100x100cm 39"x39"	100x300cm* 39"x118"	
	Slimtech 3plus	Slimtech 3plus	Slimtech 3plus	Slimtech 3plus	
<b>White Cloud</b> 	LSEGU35	LSBGU35	LSCGU35	LSAGU36	LS9GU03
<b>Soft Sand</b> 	LSEGU25	LSBGU25	LSCGU25	LSAGU26	LS9GU04
<b>Light Rock</b> 	LSEGU15	LSBGU15	LSCGU15	LSAGU16	LS9GU01
<b>Black Stone</b> 	LSEGU05	LSBGU05	LSCGU05	LSAGU06	LS9GU05
<b>Crystal Water</b> 	LSEGU45	LSBGU45	LSCGU45	LSAGU46	LS9GU02
<b>Cool Rain</b> 	LSEGU55	LSBGU55	LSCGU55	LSAGU56	LS9GU00
<b>Deep Sea</b> 	LSEGU65	LSBGU65	LSCGU65	LSAGU66	LS9GU06

### DECORI decors / decors / Dekore

	LIBECCIO 01	LIBECCIO 02	LIBECCIO 03
	15,4x22,3cm 6 <sup>1/8</sup> "x8 <sup>3/4</sup> "	15,4x22,3cm 6 <sup>1/8</sup> "x8 <sup>3/4</sup> "	15,4x22,3cm 6 <sup>1/8</sup> "x8 <sup>3/4</sup> "
<b>Warm</b>	LS9GU08	-	-
<b>Cold</b>	LS9GU07	-	-
<b>Color mix</b>	-	LS9GU09	LS9GU10

\* Per ordini inferiori alle 5 lastre sarà addebitato il costo del pallet a Euro 80,00 netto. / The cost of the pallet, Euro 80,00 net, will be charged for orders less than 5 slabs. / Pour toutes commandes inférieures à 5 dalles, un cout de 80 Euro correspondant au cout de la palette sera ajouté. / Bei Abnahme einer Menge unter 5 Platten werden Euro 80,00 Netto für Verpackung/palette belastet.

\*\* Su richiesta. Per maggiori informazioni circa quantità minime e tempi di consegna rivolgersi all'ufficio commerciale. / Upon request. For more information about minimum quantities and delivery times please contact the sales department. / Sur demande. Pour plus d'informations sur les quantités minimales et délais de livraison s'il vous plaît contacter le département des ventes. / auf Anfrage. Für weitere Infos über die Mindestmengen und Lieferzeiten wenden Sie sich bitte an unserer Verkaufsabteilung.

# LEGENDA CODICI PRODOTTO

LEGEND PRODUCT CODES

LÉGENDE CODES PRODUITS

LEGEND PRODUKTCODES

## IMBALLI packing / emballage / Verpackung

ARTICOLO	SCATOLA			PALLET				
	cm	inch	pz.	m <sup>2</sup>	kg	scat.	m <sup>2</sup>	kg
fondo 3plus	100x300	39"x118"	1	3,00	25,4	20 pz/pl	60,0	507,0
fondo 3plus	100x100	39"x39"	3	3,00	24,1	25	75,0	602,5
fondo 3plus	50x100	19 <sup>1/2</sup> "x39"	5	2,50	20,0	32	80,0	640,0
fondo 3plus	4,9x100	2"x39"	10	0,49	4,2	39	19,1	163,8
decoro libeccio	15,4x22,3	6 <sup>1/8</sup> "x8 <sup>3/4</sup> "	10	0,27	2,8	80	21,9	224,0

## LINES design Patrick Norguet

### FONDI plain tiles / fonds / Unifliesen

		*100x300cm 39"x118"
		slimtech 3plus
Line Blue		LSALI06
Line Grey		LSALI26

### IMBALLI packing / emballage / Verpackung

ARTICOLO	SCATOLA			PALLET				
	cm	inch	pz.	m <sup>2</sup>	kg	scat.	m <sup>2</sup>	kg
fondo 3plus	100x300	39"x118"	1	3,00	25,4	20 pz/pl	60,0	507,0

## NAIVE design Patrick Norguet

### FONDI plain tiles / fonds / Unifliesen

		100x100cm 39"x39"	*100x300cm 39"x118"
		slimtech 5plus	slimtech 5plus
Naive Blue		LSCNA10	LSANA10
Naive Terra		LSCNA30	LSANA30
Naive Grey		LSCNA20	LSANA20
Naive Black		LSCNA00	LSANA00

### IMBALLI packing / emballage / Verpackung



ARTICOLO	SCATOLA			PALLET				
	cm	inch	pz.	m <sup>2</sup>	kg	scat.	m <sup>2</sup>	kg
fondo 5plus	100x300	39"x118"	1	3,00	34,5	13 pz/pl	39,0	448,5
fondo 5plus	100x100	39"x39"	2	2,00	23,0	25 pz/pl	50,0	575,0

\* Per ordini inferiori alle 5 lastre sarà addebitato il costo del pallet a Euro 80,00 netto. / The cost of the pallet, Euro 80,00 net, will be charged for orders less than 5 slabs. / Pour toutes commandes inférieures à 5 dalles, un cout de 80 Euro correspondant au cout de la palette sera ajouté. / Bei Abnahme einer Menge unter 5 Platten werden Euro 80,00 Netto für Verpackung/palette belastet.

## SLIMTECH

## MAUK design Diego Grandi

## FONDI plain tiles / fonds / Unifliesen

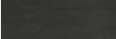
		CUADRA	ESA	SPINA
		<b>57,6cm</b> 22 <sup>5/8"</sup>	<b>38,3cm</b> 15 <sup>1/8"</sup>	<b>8,7x13,5x26,0cm</b> 3 <sup>3/8"</sup> x5 <sup>3/8"</sup> x10 <sup>1/8"</sup>
		slimtech 3plus	slimtech 3plus	slimtech 3mm
<b>Sabbiata</b>		LS9MK05	-	LS9MK01
<b>Naturale</b>		LS9MK06	LS9MK04	-
<b>Lappata</b>		LS9MK07	LS9MK03	LS9MK00

## IMBALLI packing / emballage / Verpackung

ARTICOLO	SCATOLA					PALLET		
	cm	inch	pz.	mq	kg	scat.	mq	kg
cuadra 3plus	57,6	22 <sup>5/8"</sup>	6	1,73	15,5	5	8,6	77,5
esa 3plus	38,3	15 <sup>1/8"</sup>	12	0,77	6,4	20	15,4	127,0
spina 3mm	25,8x13,5x8,7	10 <sup>1/8"</sup> x5 <sup>3/8"</sup> x3 <sup>3/8"</sup>	15	0,18	1,5	80	14,8	120,0

## NEST design Hok Product Design

## IMBALLI packing / emballage / Verpackung

ARTICOLO	SCATOLA					PALLET		
	cm	inch	pz.	mq	kg	scat.	mq	kg
esagono L 50 (3,5mm)	100x86,6	39"x34 <sup>1/8"</sup>	1	0,65	5,2	-	-	-
esagono L 25 (3,5mm)	50x43,2	19 <sup>1/2"</sup> x17"	1	0,16	1,3	-	-	-
esagono L 6,2 (3,5mm)	12,5x10,8	5"x4 <sup>1/4"</sup>	1	0,01	0,1	-	-	-
ett.+tria. L 50 (3,5mm)	100x86,6	39"x34 <sup>1/8"</sup>	1	0,65	5,2	-	-	-
ett.+tria. L 25 (3,5mm)	50x43,2	19 <sup>1/2"</sup> x17"	1	0,16	1,3	-	-	-
ett.+tria. L 6,2 (3,5mm)	12,5x10,8	5"x4 <sup>1/4"</sup>	1	0,01	0,1	-	-	-
esagono L 50 (5,5mm)	100x86,6	39"x34 <sup>1/8"</sup>	1	0,65	8,3	-	-	-
esagono L 25 (5,5mm)	50x43,2	19 <sup>1/2"</sup> x17"	1	0,16	2,1	-	-	-
esagono L 6,2 (5,5mm)	12,5x10,8	5"x4 <sup>1/4"</sup>	1	0,01	0,1	-	-	-
ett.+tria. L 50 (5,5mm)	100x86,6	39"x34 <sup>1/8"</sup>	1	0,65	8,3	-	-	-
ett.+tria. L 25 (5,5mm)	50x43,2	19 <sup>1/2"</sup> x17"	1	0,16	2,1	-	-	-
ett.+tria. L 6,2 (5,5mm)	12,5x10,8	5"x4 <sup>1/4"</sup>	1	0,01	0,1	-	-	-

# LEGENDA CODICI PRODOTTO





LEGEND PRODUCT CODES

LÉGENDE CODES PRODUITS

LEGEND PRODUKTCODES

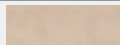
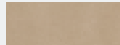
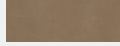
## RE-EVOLUTION

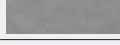
**FONDI** plain tiles / fonds / Unifliesen

		<b>4,9x100cm</b> 2"x39"	<b>50x100cm</b> 19 1/2"x39"	<b>100x100cm</b> 39"x39"	<b>100x300cm*</b> 39"x118"
		<b>slimtech 3plus</b>	<b>slimtech 3plus</b>	<b>slimtech 3plus</b>	<b>slimtech 3plus</b>
<b>SRW010</b>		LSERE65	LSBRE65	LSCRE65	LSARE65
<b>SRW020</b>		LSERE75	LSBRE75	LSCRE75	LSARE75
<b>SRW030</b>		LSERE85	LSBRE85	LSCRE85	LSARE85
<b>SRC010</b>		LSERE15	LSBRE15	LSCRE15	LSARE15
<b>SRC020</b>		LSERE25	LSBRE25	LSCRE25	LSARE25
<b>SRC030</b>		LSERE35	LSBRE35	LSCRE35	LSARE35

**IMBALLI** packing / emballage / Verpackung

ARTICOLO	SCATOLA				PALLET			
	cm	inch	pz.	m <sup>2</sup>	kg	scat.	m <sup>2</sup>	kg
fondo 3plus	100x300	39"x118"	1	3,00	25,4	20	60,0	507,0
fondo 3plus	100x100	39"x39"	3	3,00	24,1	25	75,0	602,5
fondo 3plus	50x100	19 1/2"x39"	5	2,50	20,0	32	80,0	640,0
fondo 3plus	4,9x100	2"x39"	10	0,49	4,2	39	19,1	163,8

\* Per ordini inferiori alle 5 lastre sarà addebitato il costo del pallet a Euro 80,00 netto. / The cost of the pallet, Euro 80,00 net, will be charged for orders less than 5 slabs. / Pour toutes commandes inférieures à 5 dalles, un cout de 80 Euro correspondant au cout de la palette sera ajouté. / Bei Abnahme einer Menge unter 5 Platten werden Euro 80,00 Netto für Verpackung/palette belastet.

## SHADE and STREETS design Diego Grandi

**FONDI** plain tiles / fonds / unifliesen

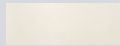
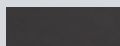
		<b>4,9x100cm</b> 2"x39"	<b>50x100cm</b> 19 1/2"x39"	<b>100x100cm</b> 39"x39"	<b>100x300cm*</b> 39"x118"
		<b>slimtech 3plus</b>	<b>slimtech 3plus</b>	<b>slimtech 3plus</b>	<b>slimtech 3plus</b>
<b>Milk</b>		LSESD05	LSBSD05	LSCSD05	LSASD05
<b>Black Coffee</b>		LSESD15	LSBSD15	LSCSD15	LSASD15

\* Per ordini inferiori alle 5 lastre sarà addebitato il costo del pallet a Euro 80,00 netto. / The cost of the pallet, Euro 80,00 net, will be charged for orders less than 5 slabs. / Pour toutes commandes inférieures à 5 dalles, un cout de 80 Euro correspondant au cout de la palette sera ajouté. / Bei Abnahme einer Menge unter 5 Platten werden Euro 80,00 Netto für Verpackung/palette belastet.







# SLIMTECH

## IMBALLI packing / emballage / Verpackung

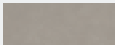
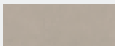
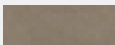
ARTICOLO	SCATOLA					PALLET		
	cm	inch	pz.	m <sup>q</sup>	kg	scat.	m <sup>q</sup>	kg
fondo 3plus	100x300	39"x118"	1	3,00	25,4	20 pz/pl	60,0	507,0
fondo 3plus	100x100	39"x39"	3	3,00	24,1	25	75,0	602,5
fondo 3plus	50x100	19 <sup>1/2</sup> "x39"	5	2,50	20,0	32	80,0	640,0
fondo 3plus	4,9x100	2"x39"	10	0,49	4,2	39	19,1	163,8
decoro streets 3mm	50x100	19 <sup>1/2</sup> "x39"	2	1,00	7,1	30	30,0	213,6

## TAKE CARE and PAD design Patrick Norguet

### FONDI plain tiles / fonds / Unifliesen

		100x100cm	100x150cm	100x300cm*
		39"x39"	39"x58"	39"x118"
		rett	rett	rett
		slimtech 5plus	slimtech 5plus	slimtech 5plus
T_snow		LSTCT30	-	LSATCT3
T_steel		LSTCT40	-	LSATCT4
T_moon		LSTCT10	-	LSATCT1
T_ground		LSTCT00	-	LSATCT0
T_night		LSTCT20	-	LSATCT2
C_snow		-	LSFTCC3	LSATCC3
C_steel		-	LSFTCC4	LSATCC4
C_moon		-	LSFTCC1	LSATCC1
C_ground		-	LSFTCC0	LSATCC0
C_night		-	LSFTCC2	LSATCC2

\* Per ordini inferiori alle 5 lastre sarà addebitato il costo del pallet a Euro 80,00 netto. / The cost of the pallet, Euro 80,00 net, will be charged for orders less than 5 slabs. / Pour toutes commandes inférieures à 5 dalles, un cout de 80 Euro correspondant au cout de la palette sera ajouté. / Bei Abnahme einer Menge unter 5 Platten werden Euro 80,00 Netto für Verpackung/palette belastet.











# LEGENDA CODICI PRODOTTO

LEGEND PRODUCT CODES

LÉGENDE CODES PRODUITS

LEGEND PRODUKTCODES

## DECORI decors / decors / dekore





			DECORO PAD TAMIS					DECORO PAD OAKLAND	
			100x300cm 39"x118"					100x300cm 39"x118"	
			Slimtech 5plus					Slimtech 5plus	
Snow		A	LSATM63		LSATM83				
		B	LSATM68						
		C	LSATM73						
Steel		A	LSATM64		LSATM84				
		B	LSATM69						
		C	LSATM74						
Moon		A	LSATM61		LSATM81				
		B	LSATM66						
		C	LSATM71						
Ground		A	LSATM60		LSATM80				
		B	LSATM65						
		C	LSATM70						
Night		A	LSATM62		LSATM82				
		B	LSATM67						
		C	LSATM72						

## IMBALLI packing / emballage / Verpackung

ARTICOLO	SCATOLA					PALLET		
	cm	inch	pz.	mq	kg	scat.	mq	kg
fondo 5plus	100x150	39"x59"	2	3,00	34,5	25	75,0	862,5
fondo 5plus	300x100	118"x39"	1	3,00	34,5	13	39,0	448,5
fondo 5plus	100x100	39"x39"	2	2,00	23,0	25	50,0	575,0
decoro pad	300x100	118"x39"	1	3,00	34,5	13	39,0	448,5

# TIMELESS MARBLE and FILIGRANE design Philippe Nigro

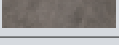
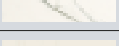
## FONDI plain tiles / fonds / unifliesen





		100x100cm 39"x39"		50x150cm 19 1/2"x59"		100x300cm* 39"x118"	
		Slimtech 5plus		Slimtech 5plus		Slimtech 5plus	
						Slimtech 5mm**	
Calacatta Gold Extra		LEV	LSCTMX4	LS0TMX4	LSATMX9		
		SAT	LSCTM40	LS0TM40	LSATM40		
Safari Amande		LEV	LSCTMX1	LS0TMX1	LSATMX1		
		SAT	LSCTM10	LS0TM10	LSATM10		
Travertino Classico		LEV	LSCTMX3	LS0TMX3	LSATMX3		
		SAT	LSCTM30	LS0TM30	LSATM30		
Pietra Gray		LEV	LSCTMX2	LS0TMX2	LSATMX2		
		SAT	LSCTM20	LS0TM20	LSATM20		
Statuario White		LEV	LSCTMX0	LS0TMX0	LSATMX0		
		SAT	LSCTM00	LS0TM00	LSATM00		
Lasa Bright		LEV	LSCTMX6	LS0TMX6	LSATM52		
		SAT	LSCTM50	LS0TM60	LSATM57		
Onice Venus		LEV	LSCTMV0	LS0TMV0	LSATMV3		
		SAT	LSCTMV5	LS0TMV5	LSATMV7		

\* Per ordini inferiori alle 5 lastre sarà addebitato il costo del pallet a Euro 80,00 netto. / The cost of the pallet, Euro 80,00 net, will be charged for orders less than 5 slabs. / Pour toutes commandes inférieures à 5 dalles, un cout de 80 Euro correspondant au cout de la palette sera ajouté. / Bei Abnahme einer Menge unter 5 Platten werden Euro 80,00 Netto für Verpackung/palette belastet.

\*\* Su richiesta. Per maggiori informazioni circa quantità minime e tempi di consegna rivolgersi all'ufficio commerciale. / Upon request. For more information about minimum quantities and delivery times please contact the sales department. / Sur demande. Pour plus d'informations sur les quantités minimales et délais de livraison s'il vous plaît contacter le département des ventes. / auf Anfrage. Für weitere Infos über die Mindestmengen und Lieferzeiten wenden Sie sich bitte an unserer Verkaufsabteilung.

# SLIMTECH

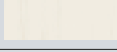
## DECORI decors / decors / dekore

		DECORO FILIGRANE PEARL		DECORO FILIGRANE HYPHEN	
		100x300cm* 39"x118"		100x300cm* 39"x118"	
		Slimtech 5plus		Slimtech 5plus	
<b>Calacatta Gold Extra</b>		LEV	-	-	-
		SAT	LSATM69	LSATM64	LSATM64
<b>Pietra Gray</b>		LEV	-	-	-
		SAT	LSATM67	LSATM62	LSATM62
<b>Statuario White</b>		LEV	-	-	-
		SAT	LSATM65	LSATM60	LSATM60
<b>Lasa Bright</b>		LEV	-	-	-
		SAT	LSATM66	LSATM61	LSATM61
<b>Onice Venus</b>		LEV	-	-	-
		SAT	LSATM68	LSATM63	LSATM63

## IMBALLI packing / emballage / Verpackung

ARTICOLO	SCATOLA					PALLET		
	cm	inch	pz.	m <sup>q</sup>	kg	scat.	m <sup>q</sup>	kg
fondo 5plus	100x300	39"x118"	1	3,00	34,5	13	39,0	448,5
fondo 5plus	100x100	39"x39"	2	2,00	23,0	25	50,0	575,0
fondo 5plus	50x150	19 <sup>1/2</sup> "x59"	2	1,50	17,5	32	48,0	560,0
decoro filigrane	100x300	39"x118"	1	3,00	34,5	13	39,0	448,5

# TYPE 32

## FONDI plain tiles / fonds / Unifliesen

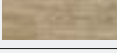
		ALFA WARM	BETA WARM	GAMMA WARM	DELTA WARM	ALFA COLD	BETA COLD	GAMMA COLD	DELTA COLD
		20x200cm 8"x79"	20x200cm 8"x79"	20x200cm 8"x79"	20x200cm 8"x79"	20x200cm 8"x79"	20x200cm 8"x79"	20x200cm 8"x79"	20x200cm 8"x79"
<b>Snow</b>		04 LSJTY04	12 LSJTY12	20 LSJTY20	28 LSJTY28	05 LSJTY05	13 LSJTY13	21 LSJTY21	29 LSJTY29
<b>Honey</b>		03 LSJTY03	11 LSJTY11	19 LSJTY19	27 LSJTY27	06 LSJTY06	14 LSJTY14	22 LSJTY22	30 LSJTY30
<b>Vintage</b>		02 LSJTY02	10 LSJTY10	18 LSJTY18	26 LSJTY26	07 LSJTY07	15 LSJTY15	23 LSJTY23	31 LSJTY31
<b>Coffee</b>		01 LSJTY01	09 LSJTY09	17 LSJTY17	25 LSJTY25	08 LSJTY08	16 LSJTY16	24 LSJTY24	32 LSJTY32

## IMBALLI packing / emballage / Verpackung

ARTICOLO	SCATOLA					PALLET		
	cm	inch	pz.	m <sup>q</sup>	kg	scat.	m <sup>q</sup>	kg
fondo 5plus	20x200	8"x79"	3	1,20	15,0	40	48,0	600,0

# LEGENDA CODICI PRODOTTO

LEGEND PRODUCT CODES

LÉGENDE CODES PRODUITS

LEGEND PRODUKTCODES

## WATERFALL

**FONDI** plain tiles / fonds / Unifliesen

			<b>50x100cm</b> 19 <sup>1/2</sup> "x39"		<b>100x100cm</b> 39"x39"		<b>100x300cm</b> 39"x118"
			rett		rett		rett
			slimtech 5plus		slimtech 5plus		slimtech 5plus
<b>Ivory Flow</b>		<b>NAT</b>	LS9WF20		LSCWF20		LSAWF20
<b>Silver Flow</b>		<b>NAT</b>	LS9WF30		LSCWF30		LSAWF30
<b>Gray Flow</b>		<b>NAT</b>	LS9WF10		LSCWF10		LSAWF10
<b>Dark Flow</b>		<b>NAT</b>	LS9WF00		LSCWF00		LSAWF00

**IMBALLI** packing / emballage / Verpackung

ARTICOLO	SCATOLA			PALLET				
	cm	inch	pz.	m <sup>q</sup>	kg	scat.	m <sup>q</sup>	kg
fondo 5plus	100x300	39"x118"	1	3,00	34,5	13 pz/pl	39,0	448,5
fondo 5plus	100x100	39"x39"	2	2,00	23,0	25	50,0	575,0
fondo 5plus	50x100	19 <sup>1/2</sup> "x39"	2	1,50	17,5	32	48,0	560,0

## WAVES design Patrick Norguet

**FONDI** plain tiles / fonds / Unifliesen

			<b>*100x300cm</b> 39"x118"
			slimtech 3plus
<b>Wave Blue A</b>			LSAWA08
<b>Wave Blue B</b>			LSAWA09
<b>Wave Grey A</b>			LSAWA28
<b>Wave Grey B</b>			LSAWA29

\* Per ordini inferiori alle 5 lastre sarà addebitato il costo del pallet a Euro 80,00 netto. / The cost of the pallet, Euro 80,00 net, will be charged for orders less than 5 slabs. / Pour toutes commandes inférieures à 5 dalles, un cout de 80 Euro correspondant au cout de la palette sera ajouté. / Bei Abnahme einer Menge unter 5 Platten werden Euro 80,00 Netto für Verpackung/palette belastet.

**IMBALLI** packing / emballage / Verpackung



ARTICOLO	SCATOLA			PALLET				
	cm	inch	pz.	m <sup>q</sup>	kg	scat.	m <sup>q</sup>	kg
fondo 5plus	20x200	8"x79"	3	1,20	15,0	40	48,0	600,0



# SLIMTECH

## WOOD-STOCK

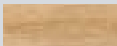
### FONDI plain tiles / fonds / Unifliesen

		20x100cm	20x150cm	20x200cm	33x300cm*
		8"x39"	8"x59"	8"x79"	13"x118"
		slimtech 5plus	slimtech 5plus	slimtech 5plus	slimtech 5plus
<b>Snow Wood</b>		LS0WS45	LSRWS45	LSJWS45	LS8WS45
<b>Cream Wood</b>		LS0WS05	LSRWS05	LSJWS05	LS8WS05
<b>Honey Wood</b>		LS0WS15	LSRWS15	LSJWS15	LS8WS15
<b>Vintage Wood</b>		LS0WS25	LSRWS25	LSJWS25	LS8WS25
<b>Coffee Wood</b>		LS0WS35	LSRWS35	LSJWS35	LS8WS35

\* Per ordini inferiori alle 15 lastre sarà addebitato il costo del pallet a Euro 80,00 netto. / The cost of the pallet, Euro 80,00 net, will be charged for orders less than 15 slabs. / Pour toutes commandes inférieures à 15 dalles, un cout de 80 Euro correspondant au cout de la palette sera ajouté. / Bei Abnahme einer Menge unter 15 Platten werden Euro 80,00 Netto für Verpackung/palette belastet.

### IMBALLI packing / emballage / Verpackung

ARTICOLO	SCATOLA			PALLET				
	cm	inch	pz.	mq	kg	scat.	mq	kg
fondo 5plus	33x300	13"x118"	1	0,99	12,5	39 pz/pl	38,6	487,0
fondo 5plus	20x200	8"x79"	3	1,20	15,0	40	48,0	600,0
fondo 5plus	20x150	8"x59"	3	0,90	11,3	60	54,0	675,0
fondo 5plus	20x100	8"x39"	3	0,60	7,5	60	36,0	450,0

# LEGENDA CODICI PRODOTTO

LEGEND PRODUCT CODES







LÉGENDE CODES PRODUITS

LEGEND PRODUKTCODES

## BASALTINA STONE PROJECT

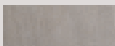
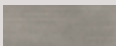
FONDI plain tiles / fonds / Unifliesen				MOSAICI mosaics / mosaïques / Mosaik		
		30x60cm 12"x24"	60x60cm 24"x24"	60x120cm 24"x48"	MOSAICO 1 28,5x28,5cm 11 <sup>1/4</sup> "x11 <sup>1/4</sup> "	MURETTO 30x60cm 12"x24"
		rett	rett	rett		
		11 mm	11 mm	12 mm		
Scalpellata		LGVBSR6	LGWBSR6	-	-	-
Sabbiata		LGVBSR0	LGWBSR0	LGXBSRA	LG9BS00	LG9BS05
Sabbiata Velvet		LGVBSRE	LGWBSRE	LGXBSRE	LG9BS19	LG9BS49
Texture		NAT LGVBSR7	LGWBSR7	-	-	-
		LEV LGVBSL7	LGWBSL7	-	-	-
Naturale		LGVBSR1	LGWBSR1	LGXBSRB	LG9BS01	LG9BS06
Stuccata		LGVBSR2	LGWBSR2	LGXBSRC	LG9BS02	LG9BS07
Lappata		LGVBSL3	LGWBSL3	LGXBSRD	LG9BS03	LG9BS08

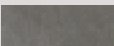
### PEZZI SPECIALI trims / pièces spéciales / Formstücke

	Scalpellata	Sabbiata	Sabbiata Velvet	Texture Nat	Texture Lev	Naturale	Stuccata	Lappata
								
battiscopa 10x60cm / 4"x24" rett	LGBBSR6	LGBBSR0	LGBBSRE	LGBBSR7	LGBBSL7	LGBBSR1	LGBBSR2	LGBBSR3
gradino plus* 35x120cm / 13 <sup>3/4</sup> "x48" rett	-	LG9BSP0	LG9BSP6	-	-	LG9BSP1	LG9BSP2	LG9BSP3
angolo dx gradino plus* 35x120cm / 13 <sup>3/4</sup> "x48" rett	-	LG9BSD0	LG9BSD7	-	-	LG9BSD1	LG9BSD2	LG9BSD3
angolo sx gradino plus* 35x120cm / 13 <sup>3/4</sup> "x48" rett	-	LG9BSS0	LG9BSS7	-	-	LG9BSS1	LG9BSS2	LG9BSS3
gradino plus* 35x60cm / 13 <sup>3/4</sup> "x24" rett	LG9BSX6	-	-	LG9BSX7	LG9BSX8	-	-	-
angolo dx gradino plus* 35x35cm / 13 <sup>3/4</sup> "x13 <sup>3/4</sup> " rett	LG9BSY6	-	-	LG9BSY7	LG9BSY8	-	-	-
angolo sx gradino plus* 35x35cm / 13 <sup>3/4</sup> "x13 <sup>3/4</sup> " rett	LG9BSZ6	-	-	LG9BSZ7	LG9BSZ8	-	-	-
raccordo jolly 1,3x30cm / 1/2"x12" rett	LG9BS36	LG9BS31	LG9BS31	LG9BS38	LG9BS37	LG9BS32	LG9BS33	LG9BS34
beak jolly 1,3x1,3cm / 1/2"x1/2" rett	LG9BS45	LG9BS40	LG9BS40	LG9BS48	LG9BS47	LG9BS41	LG9BS42	LG9BS43

### IMBALLI packing / emballage / Verpackung

ARTICOLO	SCATOLA				PALLET			
	cm	inch	pz.	mq	kg	scat.	mq	kg
fondo	60x120	24"x48"	2	1,44	40,8	15	21,6	612,0
fondo	60x60	24"x24"	4	1,44	35,0	24	34,6	840,0
fondo	30x60	12"x24"	8	1,44	34,9	32	46,1	1116,8
mosaico 1	28,5x28,5	11 <sup>1/4</sup> "x11 <sup>1/4</sup> "	5	0,41	7,8	48	19,5	372,0
muretto	30x60	12"x24"	4	0,72	15,2	30	21,6	456,0
battiscopa	10x60	4"x24"	12	7,2 m.l.	18,0	55	396,0 m.l.	990,0
gradino plus	35x120	13 <sup>3/4</sup> "x48"	2	0,84	23,2	16	13,4	371,2
angolo gradino plus	35x120	13 <sup>3/4</sup> "x48"	1	0,42	13,5	16	6,7	216,0
gradino plus	35x60	13 <sup>3/4</sup> "x24"	4	0,84	23,2	16	13,4	371,2
angolo gradino plus	35x35	13 <sup>3/4</sup> "x13 <sup>3/4</sup> "	2	0,25	7,4	36	8,8	266,4
raccordo jolly	1,3x30	1/2"x12"	8	-	0,3	-	-	-
beak	1,3x1,3	1/2"x1/2"	4	-	-	-	-	-

## GRES AND MORE

## BIO LUMBER

FONDI plain tiles / fonds / Unifliesen				DECORI decors / articles / Dekore		
		20x120cm 8"x48"	30x120cm 12"x48"	30x120cm 12"x48"	CLUSTER MIX 20x20cm 8"x8"	BEEHIVE 20x120cm 8"x48"
		rett	rett	rett		
		10 mm	10 mm	20 mm - SYSTEM L2		
Lodge Grove		LG7BL30	LG6BL30	LG6K235	LGHBL30	LG7BLB3
Lodge Greige		LG7BL10	LG6BL10	LG6K215	LGHBL10	-
Lodge Brown		LG7BL00	LG6BL00	LG6K205	LGHBL00	-
Lodge Grey		LG7BL20	LG6BL20	LG6K225	LGHBL20	LG7BLB2

## PEZZI SPECIALI trims / pièces spéciales / Formstücke

	Lodge Grove 	Lodge Greige 	Lodge Brown 	Lodge Grey 
<b>battiscopa</b> 10x60cm / 4"x24" rett	LGBBL30	LGBBL10	LGBBL00	LGBBL20
<b>gradino plus*</b> 35x120cm / 13 <sup>3/4</sup> "x48" rett	LG9BL30	LG9BL10	LG9BL00	LG9BL20
<b>angolo dx gradino plus*</b> 35x120cm / 13 <sup>3/4</sup> "x48" rett	LG9BLD3	LG9BLD1	LG9BLD0	LG9BLD2
<b>angolo sx gradino plus*</b> 35x120cm / 13 <sup>3/4</sup> "x48" rett	LG9BLS3	LG9BLS1	LG9BLS0	LG9BLS2

## IMBALLI packing / emballage / Verpackung

ARTICOLO	SCATOLA			PALLET				
	cm	inch	pz.	mq	kg	scat.	mq	kg
fondo	30x120	12"x48"	4	1,44	34,0	18	25,9	612,0
fondo	20x120	8"x48"	5	1,20	27,8	24	28,8	666,0
decoro beehive	20x120	8"x48"	2	0,48	11,5	54	25,9	621,0
decoro cluster mix	20x20	8"x8"	6	0,24	6,0	124	29,8	744,0
battiscopa	10x60	4"x24"	12	7,2 m.l.	18,0	60	432,0 m.l.	1080,0
gradino plus	35x120	13 <sup>3/4</sup> "x48"	2	0,84	23,2	16	13,4	371,2
angolo gradino plus	35x120	13 <sup>3/4</sup> "x48"	1	0,42	12,0	16	6,7	192,0

\* Su richiesta. Per maggiori informazioni circa quantità minime e tempi di consegna rivolgersi all'ufficio commerciale. / Upon request. For more information about minimum quantities and delivery times please contact the sales department. / Sur demande. Pour plus d'informations sur les quantités minimales et délais de livraison s'il vous plaît contacter le département des ventes. / auf Anfrage. Für weitere Infos über die Mindestmengen und Lieferzeiten wenden Sie sich bitte an unserer Verkaufsabteilung.



# LEGENDA CODICI PRODOTTO

LEGEND PRODUCT CODES

LÉGENDE CODES PRODUITS

LEGEND PRODUKTCODES

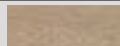
## BIO PLANK

FONDI plain tiles / fonds / Unifliesen						DECORI decors / articles / Dekore		
						<b>DECORO FENCE*</b>		
						<b>20x120cm</b> 8"x48"	<b>20x120cm</b> 8"x48"	
						<b>rett</b>		
						<b>11 mm</b>	<b>11 mm</b>	
<b>Oak Ice</b>			LG7BP30			LG7BPF3		
<b>Oak Noisette</b>			LG7BP40			LG7BPF4		
PEZZI SPECIALI trims / pièces spéciales / Formstücke								
			Oak Ice			Oak Noisette		
								
<b>battiscopa</b> 10x60cm / 4"x24" rett			LG9BPP3			LG9BPP4		
<b>gradino plus*</b> 35x120cm / 13 <sup>3/4</sup> "x48" rett			LG9BPD3			LG9BPD4		
<b>angolo dx gradino plus*</b> 35x120cm / 13 <sup>3/4</sup> "x48" rett			LG9BPS3			LG9BPS4		
<b>angolo sx gradino plus*</b> 35x120cm / 13 <sup>3/4</sup> "x48" rett								
IMBALLI packing / emballage / Verpackung								
ARTICOLO			SCATOLA			PALLET		
	cm	inch	pz.	mq	kg	scat.	mq	kg
fondo	20x120	8"x48"	5	1,20	30,6	24	28,8	734,4
decoro fence	20x120	8"x48"	4	0,96	24,5	12	11,5	294,0
battiscopa	10x60	4"x24"	12	7,2 m.l.	18,0	55	396,0 m.l.	990,0
gradino plus	35x120	13 <sup>3/4</sup> "x48"	2	0,84	23,2	16	13,4	371,2
angolo gradino plus	35x120	13 <sup>3/4</sup> "x48"	1	0,42	12,4	16	6,7	198,4
* Su richiesta. Per maggiori informazioni circa quantità minime e tempi di consegna rivolgersi all'ufficio commerciale. / Upon request. For more information about minimum quantities and delivery times please contact the sales department. / Sur demande. Pour plus d'informations sur les quantités minimales et délais de livraison s'il vous plaît contacter le département des ventes. / auf Anfrage. Für weitere Infos über die Mindestmengen und Lieferzeiten wenden Sie sich bitte an unserer Verkaufsabteilung.								



## BIO RECOVER

FONDI plain tiles / fonds / Unifliesen

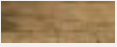

		<b>20x180cm</b> 8"x71"	<b>20x121,5cm</b> 8"x48"
		<b>rett</b>	<b>nat</b>
		<b>12 mm</b>	<b>10,5 mm</b>
<b>Warm Cream</b>		LG4BR20	LG0BR20
<b>Golden Flame</b>		LG4BR00	LG0BR00
<b>Old Walnut</b>		LG4BR10	LG0BR10

## GRES AND MORE

## DECORI decors / articles / Dekore

	FULL WHITE	FULL BLUE	FULL RED	PIED DE POULE WHITE	PIED DE POULE BLUE	PIED DE POULE RED	FRAMMENTI WHITE	FRAMMENTI BLUE	FRAMMENTI RED
	20x90cm 8"x36"	20x90cm 8"x36"	20x90cm 8"x36"	20x90cm 8"x36"	20x90cm 8"x36"	20x90cm 8"x36"	mix	mix	mix
	12 mm	12 mm	12 mm	12 mm	12 mm	12 mm	12 mm	12 mm	12 mm
<b>Warm Cream</b> 	LG3BRW2	LG3BRB2	LG3BRF2	LG3BRP2	LG3BRD2	LG3BRR2	LGMBRW2	LGMBRB2	LGMBRR2
<b>Golden Flame</b> 	LG3BRW0	LG3BRB0	LG3BRF0	LG3BRP0	LG3BRD0	LG3BRR0	LGMBRW0	LGMBRB0	LGMBRR0
<b>Old Walnut</b> 	LG3BRW1	LG3BRB1	LG3BRF1	LG3BRP1	LG3BRD1	LG3BRR1	LGMBRW1	LGMBRB1	LGMBRR1

## PEZZI SPECIALI trims / pièces spéciales / Formstücke

	Warm Cream 	Golden Flame 	Old Walnut 
<b>battiscopa</b> 10x60cm / 4"x24" rett	LGBBR20	LGBBR00	LGBBR10
<b>gradino plus*</b> 35x120cm / 13 <sup>3/4</sup> "x48" rett	LG9BRP2	LG9BRP0	LG9BRP1
<b>angolo dx gradino plus*</b> 35x120cm / 13 <sup>3/4</sup> "x48" rett	LG9BRD2	LG9BRD0	LG9BRD1
<b>angolo sx gradino plus*</b> 35x120cm / 13 <sup>3/4</sup> "x48" rett	LG9BRS2	LG9BRS0	LG9BRS1





## IMBALLI packing / emballage / Verpackung

ARTICOLO	SCATOLA					PALLET		
	cm	inch	pz.	mq	kg	scat.	mq	kg
fondo	20x180	8"x71"	3	1,08	30,0	48	51,8	1440,0
fondo	20x121,5	8"x48"	5	1,22	29,0	24	29,2	696,0
decoro full	20x90	8"x36"	4	0,72	20,0	30	21,6	600,0
decoro pied de poule	20x90	8"x36"	4	0,72	20,0	30	21,6	600,0
decoro frammenti	-	-	6	0,29	9,0	96	27,6	864,0
battiscopa	10x60	4"x24"	12	7,2 m.l.	16,0	56	403,0 m.l.	896,0
gradino plus	35x120	13 <sup>3/4</sup> "x48"	2	0,84	23,2	16	13,4	371,2
angolo gradino plus	35x120	13 <sup>3/4</sup> "x48"	1	0,42	12,4	16	6,7	198,4

## BIO TIMBER

## FONDI plain tiles / fonds / Unifliesen

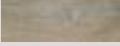
## DECORI E MOSAICI decors and mosaics / décors et mosaïques / Dekore und Mosaik

		COMPASS	STRIP	TRIANGLES
	20x120cm 8"x48"	20x120cm 8"x48"	20x120cm 8"x48"	20x120cm 8"x48"
	rett			
	11 mm	11 mm	11 mm	11 mm
<b>Oak Patinato Chiaro</b> 	LG7BI00	LG7BIC0	LG7BIS0	LG7BIT0
<b>Oak Patinato Scuro</b> 	LG7BI10	LG7BIC1	LG7BIS1	LG7BIT1
<b>Oak Provenzale</b> 	LG7BI20	LG7BIC2	LG7BIS2	LG7BIT2
<b>Oak Grigio</b> 	LG7BI40	LG7BIC4	LG7BIS4	LG7BIT4

# LEGENDA CODICI PRODOTTO

LEGEND PRODUCT CODES

LÉGENDE CODES PRODUITS

LEGEND PRODUKTCODES

## PEZZI SPECIALI trims / pièces spéciales / Formstücke

	Oak Patinato Chiaro 	Oak Patinato Scuro 	Oak Provenzale 	Oak Grigio 
<b>battiscopa</b> 10x60,4cm / 4"x24" rett	LG9BBI00	LG9BBI10	LG9BBI20	LG9BBI40
<b>gradino plus*</b> 35x120cm / 13 <sup>3/4</sup> "x48" rett	LG9BIG0	LG9BIG1	LG9BIG2	LG9BIG4
<b>angolo dx gradino plus*</b> 35x120cm / 13 <sup>3/4</sup> "x48" rett	LG9BID0	LG9BID1	LG9BID2	LG9BID4
<b>angolo sx gradino plus*</b> 35x120cm / 13 <sup>3/4</sup> "x48" rett	LG9BIS0	LG9BIS1	LG9BIS2	LG9BIS4



## IMBALLI packing / emballage / Verpackung

ARTICOLO	SCATOLA				PALLET			
	cm	inch	pz.	mq	kg	scat.	mq	kg
fondo	20x120	8"x48"	5	1,20	30,6	24	28,8	734,4
compass	20x120	8"x48"	2	0,48	12,3	54	25,9	661,5
strip	20x120	8"x48"	2	0,48	12,3	54	25,9	661,5
triangles	20x120	8"x48"	2	0,48	12,3	54	25,9	661,5
battiscopa	10x60	4"x24"	12	7,2 m.l.	18,0	56	403,0 m.l.	1008,0
gradino plus	35x120	13 <sup>3/4</sup> "x48"	2	0,84	23,2	16	13,4	371,2
angolo gradino plus	35x120	13 <sup>3/4</sup> "x48"	1	0,42	12,4	16	6,7	198,4

\* Su richiesta. Per maggiori informazioni circa quantità minime e tempi di consegna rivolgersi all'ufficio commerciale. / Upon request. For more information about minimum quantities and delivery times please contact the sales department. / Sur demande. Pour plus d'informations sur les quantités minimales et délais de livraison s'il vous plaît contacter le département des ventes. / auf Anfrage. Für weitere Infos über die Mindestmengen und Lieferzeiten wenden Sie sich bitte an unserer Verkaufsabteilung.

# CITY design Diego Grandi

## FONDI plain tiles / fonds / Unifliesen



	30x60cm 12"x24"	rett	11 mm
<b>Moscova antracite 3D</b> 	LG9CY00		
<b>Cordusio bronze 3D</b> 	LG9CY01		

## IMBALLI packing / emballage / Verpackung

ARTICOLO	SCATOLA				PALLET			
	cm	inch	pz.	mq	kg	scat.	mq	kg
fondo	30x60	12"x24"	4	0,72	15,6	24	17,3	374,4

## GRES AND MORE

## CLIFFSTONE

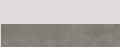
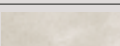
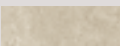
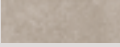
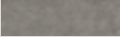



FONDI plain tiles / fonds / Unfliesen										
		20x60cm 8"x24"	30x60cm 12"x24"	40x60cm 16"x24"	60x60cm 24"x24"	60x90cm 24"x36"	90x90cm 36"x36"	60x120cm 24"x48"	60x60cm 24"x24"	
		rett	rett	rett	rett	rett	rett	rett	rett	
		10 mm	10 mm	10 mm	10 mm	10 mm	11 mm	10 mm	20 mm - SYSTEM L2	
White Dover		LAPP	LGKCLX3	LGVCLX3	LGJCLX3	LGWCLX3	LGACLX3	LG9CL35	LGXCLX3	-
		NAT	LGKCL30	LGVCL30	LGJCL30	LGWCL31	LGACL30	LG9CL31	LGXCL31	LGWK287
		ANT	LGKCLA3	LGVCLA3	LGJCLA3	LGWCLA3	LGACLA3	LG9CLA3	LGXCLA3	-
		GRIP	-	-	-	LGWCL35	-	-	-	-
Beige Madeira		LAPP	LGKCLX0	LGVCLX0	LGJCLX0	LGWCLX0	LGACLX0	LG9CL05	LGXCLX0	-
		NAT	LGKCL00	LGVCL00	LGJCL00	LGWCL01	LGACL00	LG9CL01	LGXCL01	LGWK281
		ANT	LGKCLA0	LGVCLA0	LGJCLA0	LGWCLA0	LGACLA0	LG9CLA0	LGXCLA0	-
		GRIP	-	-	-	LGWCL05	-	-	-	-
Taupe Moher		LAPP	LGKCLX2	LGVCLX2	LGJCLX2	LGWCLX2	LGACLX2	LG9CL25	LGXCLX2	-
		NAT	LGKCL20	LGVCL20	LGJCL20	LGWCL21	LGACL20	LG9CL21	LGXCL21	LGWK285
		ANT	LGKCLA2	LGVCLA2	LGJCLA2	LGWCLA2	LGACLA2	LG9CLA2	LGXCLA2	-
		GRIP	-	-	-	LGWCL25	-	-	-	-
Grey Tenerife		LAPP	LGKCLX1	LGVCLX1	LGJCLX1	LGWCLX1	LGACLX1	LG9CL15	LGXCLX1	-
		NAT	LGKCL10	LGVCL10	LGJCL10	LGWCL11	LGACL10	LG9CL11	LGXCL11	LGWK283
		ANT	LGKCLA1	LGVCLA1	LGJCLA1	LGWCLA1	LGACLA1	LG9CLA1	LGXCLA1	-
		GRIP	-	-	-	LGWCL15	-	-	-	-
MOSAICI mosaics / mosaïques / Mosaik										
MURETTO					MOSAICO 16					
30x60cm 12"x24"					30x30cm 12"x12"					
White dover		LAPP	LGVCLM3					LG9CLM3		
Beige Madeira		LAPP	LGVCLM0					LG9CLM0		
Taupe Moher		LAPP	LGVCLM2					LG9CLM2		
Grey Tenerife		LAPP	LGVCLM1					LG9CLM1		

# LEGENDA CODICI PRODOTTO

LEGEND PRODUCT CODES

LÉGENDE CODES PRODUITS

LEGEND PRODUKTCODES

		White Dover 	Beige Madeira 	Taupe Moher 	Grey Tenerife 
<b>battiscopa</b> 10x60cm / 4"x24"	LAPP RETT	LGBCLX3	LGBCLX0	LGBCLX2	LGBCLX1
	NAT RETT	LGBCL30	LGBCL00	LGBCL20	LGBCL10
	ANT RETT	LGBCLA3	LGBCLA0	LGBCLA2	LGBCLA1
<b>gradino plus*</b> 35x120cm / 13 <sup>3/4</sup> "x48"	LAPP RETT	LG8CLX3	LG8CLX0	LG8CLX2	LG8CLX1
	NAT RETT	LG8CL30	LG8CL00	LG8CL20	LG8CL10
	ANT RETT	LG8CLA3	LG8CLA0	LG8CLA2	LG8CLA1
<b>angolo dx gradino plus*</b> 35x120cm / 13 <sup>3/4</sup> "x48"	LAPP RETT	LG8CLC6	LG8CLC0	LG8CLC4	LG8CLC2
	NAT RETT	LG8CL31	LG8CL01	LG8CL21	LG8CL11
	ANT RETT	LG8CLB6	LG8CLB0	LG8CLB4	LG8CLB2
<b>angolo sx gradino plus*</b> 35x120cm / 13 <sup>3/4</sup> "x48"	LAPP RETT	LG8CLC7	LG8CLC1	LG8CLC5	LG8CLC3
	NAT RETT	LG8CL32	LG8CL02	LG8CL22	LG8CL12
	ANT RETT	LG8CLB7	LG8CLB1	LG8CLB5	LG8CLB3
<b>gradino plus*</b> 35x60cm / 13 <sup>3/4</sup> "x24"	GRIP RETT	LG2CL30	LG2CL00	LG2CL20	LG2CL10
<b>angolo sx / dx gradino plus*</b> 35x35cm / 13 <sup>3/4</sup> "x13 <sup>3/4</sup> "	GRIP RETT	LG2CL31	LG2CL01	LG2CL21	LG2CL11

\* Su richiesta. Per maggiori informazioni circa quantità minime e tempi di consegna rivolgersi all'ufficio commerciale. / Upon request. For more information about minimum quantities and delivery times please contact the sales department. / Sur demande. Pour plus d'informations sur les quantités minimales et délais de livraison s'il vous plaît contacter le département des ventes. / auf Anfrage. Für weitere Infos über die Mindestmengen und Lieferzeiten wenden Sie sich bitte an unserer Verkaufsabteilung.

## IMBALLI packing / emballage / Verpackung

ARTICOLO	SCATOLA				PALLET			
	cm	inch	pz.	mq	kg	scat.	mq	kg
fondo	60x120	24"x48"	2	1,44	35,5	36	51,8	1278,0
fondo	90x90	36"x36"	2	1,62	40,0	30	48,6	1200,0
fondo	60x90	24"x36"	3	1,62	40,0	30	48,6	1200,0
fondo	60x60	24"x24"	4	1,44	32,5	32	46,1	1040,0
fondo	40x60	16"x24"	4	0,96	21,6	24	23,0	518,4
fondo	30x60	12"x24"	8	1,44	32,5	32	46,1	1040,0
fondo	20x60	8"x24"	8	0,96	21,6	48	46,1	1036,8
muretto	30x60	12"x24"	4	0,72	15,6	30	21,6	468,0
mosaico 16	30x30	12"x12"	5	0,45	10,0	60	27,0	600,0
battiscopa	10x60	4"x24"	12	7,2 m.l.	16,0	60	432,0 m.l.	960,0
gradino plus	35x120	13 <sup>3/4</sup> "x48"	2	0,84	23,2	16	13,4	371,2
angolo gradino plus	35x120	13 <sup>3/4</sup> "x48"	1	0,42	12,4	16	6,7	198,4
gradino plus	35x60	13 <sup>3/4</sup> "x24"	4	0,84	21,2	16	13,4	339,2
angolo gradino plus	35x35	13 <sup>3/4</sup> "x13 <sup>3/4</sup> "	2	0,25	6,7	36	8,8	241,2



## GRES AND MORE

## DISTRICT

## FONDI plain tiles / fonds / Unifliesen

			30x60cm 12"x24"	60x60cm 24"x24"	45x90cm 18"x36"	90x90cm 36"x36"
			rett 10 mm	rett 10 mm	rett 11 mm	rett 11 mm
Street		NAT	LGVDS30	LGWDS30	LGGDS30	LG9DS30
		GRIP	-	LGWDS35	-	-
Avenue		NAT	LGVDS00	LGWDS00	LGGDS00	LG9DS00
		GRIP	-	LGWDS05	-	-
Boulevard		NAT	LGVDS10	LGWDS10	LGGDS10	LG9DS10
		GRIP	-	LGWDS15	-	-
Route		NAT	LGVDS20	LGWDS20	LGGDS20	LG9DS20
		GRIP	-	LGWDS25	-	-

## DECORI E MOSAICI decors and mosaics / décors et mosaïques / Dekore und Mosaïke

		METROPOLITAN	GUGGENHEIM	MOMA	CENTRAL PARK	BRYANT PARK	QUEENS MIX	MURETTO	MOSAICO 81	MOSAICO MATTONE
		60x60cm 24"x24"	60x60cm 24"x24"	60x60cm 24"x24"	30x30cm 12"x12"	30x30cm 12"x12"	30x30cm 12"x12"	30x60cm 12"x24"	30x30cm 12"x12"	30x30cm 12"x12"
Street		LGWDST3	LGWDSH3	LGWDSM3	LGPDS3	LGPDS30	LGPDSQ3	LGVDS83	LG9DS83	LG9DS93
Avenue		LGWDST0	LGWDSH0	LGWDSM0	LGPDS0	LGPDS00	LGPDSQ0	LGVDS80	LG9DS80	LG9DS90
Boulevard		LGWDST1	LGWDSH1	LGWDSM1	LGPDS1	LGPDS10	LGPDSQ1	LGVDS81	LG9DS81	LG9DS91
Route		LGWDST2	LGWDSH2	LGWDSM2	LGPDS2	LGPDS20	LGPDSQ2	LGVDS82	LG9DS82	LG9DS92

## PEZZI SPECIALI trims / pièces spéciales / Formstücke

		Street	Avenue	Boulevard	Route
battiscopa 10x60cm / 4"x24" rett	NAT	LGBDS30	LGBDS00	LGBDS10	LGBDS20
	GRIP	-	-	-	-
gradino plus* 35x120cm / 13 <sup>3/4</sup> "x48" rett	NAT	LG9DSG3	LG9DSG0	LG9DSG1	LG9DSG2
	GRIP	LG9DSG8	LG9DSG5	LG9DSG6	LG9DSG7
angolo gradino plus* 35x120cm / 13 <sup>3/4</sup> "x48" rett	NAT	LG9DSA3	LG9DSA0	LG9DSA1	LG9DSA2
	GRIP	LG9DSA8	LG9DSA5	LG9DSA6	LG9DSA7

\* Su richiesta. Per maggiori informazioni circa quantità minime e tempi di consegna rivolgersi all'ufficio commerciale. / Upon request. For more information about minimum quantities and delivery times please contact the sales department. / Sur demande. Pour plus d'informations sur les quantités minimales et délais de livraison s'il vous plaît contacter le département des ventes. / auf Anfrage. Für weitere Infos über die Mindestmengen und Lieferzeiten wenden Sie sich bitte an unserer Verkaufsabteilung.

# LEGENDA CODICI PRODOTTO

LEGEND PRODUCT CODES

LÉGENDE CODES PRODUITS









LEGEND PRODUKTCODES

## IMBALLI packing / emballage / Verpackung

ARTICOLO	SCATOLA				PALLET			
	cm	inch	pz.	mq	kg	scat.	mq	kg
fondo	90x90	36"x36"	2	1,62	40,0	30	48,6	1200,0
fondo	45x90	18"x36"	3	1,22	30,0	30	36,5	900,0
fondo	60x60	24"x24"	4	1,44	32,5	32	46,1	1040,0
fondo	30x60	12"x24"	8	1,44	32,5	32	46,1	1040,0
decoro metropolitan	60x60	24"x24"	2	0,72	18,0	40	28,8	720,0
decoro guggenheim	60x60	24"x24"	2	0,72	18,0	40	28,8	720,0
decoro moma	60x60	24"x24"	2	0,72	18,0	40	28,8	720,0
decoro central park	30x30	12"x12"	4	0,36	9,0	60	21,6	540,0
decoro bryant park	30x30	12"x12"	4	0,36	9,0	60	21,6	540,0
decoro queens mix	30x30	12"x12"	4	0,36	9,0	60	21,6	540,0
muretto	30x60	12"x24"	4	0,72	15,6	30	21,6	468,0
mosaico 81	30x30	12"x12"	5	0,45	10,0	60	27,0	600,0
mosaico mattone	30x30	12"x12"	5	0,45	10,0	60	27,0	600,0
battiscopa	10x60	4"x24"	12	7,2 m.l.	16,0	60	432,0 m.l.	960,0
gradino plus	35x60	13 <sup>3/4</sup> "x24"	4	0,84	21,2	16	13,4	339,2
angolo gradino plus	35x35	13 <sup>3/4</sup> "x13 <sup>3/4</sup> "	2	0,25	8,0	36	8,8	288,0





# DREAMING

## FONDI plain tiles / fonds / Unifliesen

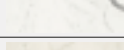
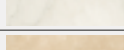
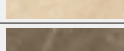
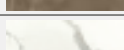

			30x60cm	60x60cm	73x73cm	75x75cm	58x116cm	60x120cm
			12"x24"	24"x24"	29"x29"	30"x30"	23"x46"	24"x48"
			rett	rett	rett	rett	rett	rett
			10 mm	10 mm	11 mm	11 mm	10 mm	10 mm
Imperial Onyx		LUX	LGVET97	LGWET97	LGOET97	-	LGXETX3	-
		VELVET	LGVET92	LGWET92	-	LGOET92	-	LGXETV3
Lasa Aurora		LUX	LGVET98	LGWET98	LGOET98	-	LGXETX4	-
		VELVET	LGVET93	LGWET93	-	LGOET93	-	LGXETV4
Bianco Statuario		LUX	LGVETL4	LGWETL4	LGOET45	-	LGXETX9	-
		VELVET	LGVETR4	LGWETR4	-	LGOETR4	-	LGXETV9
Crystal White		LUX	LGVETX0	LGWETV0	LGOET05	-	-	-
		VELVET	LGVETR0	LGWETR0	-	LGOETR0	-	-
Romance Safari		LUX	LGVETX1	LGWETV1	LGOET15	-	-	-
		VELVET	LGVETR1	LGWETR1	-	LGOETR1	-	-
Passion Pulpis		LUX	LGVETX2	LGWETV2	LGOET25	-	-	-
		VELVET	LGVETR2	LGWETR2	-	LGOETR2	-	-
Calacatta Shine		LUX	LGVETX6	LGWETV6	LGOET65	-	LGXETX8	-
		VELVET	LGVETR6	LGWETR6	-	LGOETR6	-	LGXETV8
Gray Stone		LUX	LGVETX7	LGWETV7	LGOET75	-	LGXETX2	-
		VELVET	LGVETR7	LGWETR7	-	LGOETR7	-	LGXETV2

# GRES AND MORE

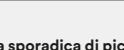
## MOSAICI mosaics / mosaïques / Mosaik

MOSAICO BASIC			
30x30cm 12"x12"			
Imperial Onyx		LUX	LG9ETM3
Lasa Aurora		LUX	LG9ETM9
Bianco Statuario		LUX	LG9ETM4
Crystal White		LUX	LG9ETM0
Romance Safari		LUX	LG9ETM1
Passion Pulpis		LUX	LG9ETM2
Calacatta Shine		LUX	LG9ETM7
Gray Stone		LUX	LG9ETM8

## DECORI decors / articles / Dekore

DECORO SCRAPS		
60x60cm 24"x24"		
Bianco		LGWETS4
Gray		LGWETS8

**\*FINITURA LUX** La presenza sporadica di piccole disuniformità o di puntini sulla superficie è da ritenersi come caratteristica del materiale e della particolare lavorazione. / LUX SURFACE FINISH The occasional presence of small inconsistencies or of little spots on the surface is to be considered a characteristic of the material and of its particular manufacture. / FINITION LUX La présence sporadique de petites déformations ou de petits points sur la surface est considérée comme caractéristique du matériau et du traitement spécial. / LUX OBERFLÄCHE Die sporadische Gegenwart von kleinen Unebenheiten oder Pünktchen auf der Oberfläche ist als Merkmal des Materials und der besonderen Fertigungsart zu betrachten.

## PEZZI SPECIALI trims / pièces spéciales / Formstücke

		Imperial Onyx	Lasa Aurora	Bianco Statuario	Crystal White	Romance Safari	Passion Pulpis	Calacatta Shine	Gray Stone
									
<b>battiscopa</b> 10x60cm / 4"x24" rett	LUX	LGBETX5	LGBETX9	LGBETX4	LGBETX0	LGBETX1	LGBETX2	LGBETX7	LGBETX8
	VELVET	LGBETR5	LGBETRA	LGBETR4	LGBETR0	LGBETR1	LGBETR2	LGBETR7	LGBETR8
<b>gradino plus*</b> 35x60cm / 13 <sup>3/4</sup> "x24" rett	LUX	LG9ET90	LG9ETG95	LG9ETG4	LG9ETG0	LG9ETG1	LG9ETG2	LG9ETG3	LG9ET80
	VELVET	LG9ET91	LG9ET96	LG9ETG9	LG9ETG5	LG9ETG6	LG9ETG7	LG9ETG8	LG9ET81
<b>angolo gradino plus*</b> 35x35cm / 13 <sup>3/4</sup> "x13 <sup>3/4</sup> " rett	LUX	LG9ET60	LG9ET65	LG9ETD4	LG9ETD0	LG9ETD1	LG9ETD2	LG9ETD3	LG9ET70
	VELVET	LG9ET61	LG9ET66	LG9ETD9	LG9ETD5	LG9ETD6	LG9ETD7	LG9ETD8	LG9ET71
<b>raccordo jolly</b> 1,3x30cm / 1/2"x12" rett	LUX	LG9ET55	LG9ET57	LG9ETJ4	LG9ETJ0	LG9ETJ1	LG9ETJ2	LG9ETJ7	LG9ET85
	VELVET	LG9ET56	LG9ET58	LG9ETJ9	LG9ETJ5	LG9ETJ6	LG9ETJ3	LG9ETJ8	LG9ET86
<b>beak jolly</b> 1,3x2cm / 1/2"x3/4" rett	LUX	LG9ET50	LG9ET52	LG9ETK4	LG9ETK0	LG9ETK1	LG9ETK2	LG9ETK3	LG9ET75
	VELVET	LG9ET51	LG9ET53	LG9ETK9	LG9ETK5	LG9ETK6	LG9ETK7	LG9ETK8	LG9ET76

**\* Su richiesta. Per maggiori informazioni circa quantità minime e tempi di consegna rivolgersi all'ufficio commerciale.** / Upon request. For more information about minimum quantities and delivery times please contact the sales department. / Sur demande. Pour plus d'informations sur les quantités minimales et délais de livraison s'il vous plaît contacter le département des ventes. / auf Anfrage. Für weitere Infos über die Mindestmengen und Lieferzeiten wenden Sie sich bitte an unserer Verkaufsabteilung.

# LEGENDA CODICI PRODOTTO

LEGEND PRODUCT CODES

LÉGENDE CODES PRODUITS



LEGEND PRODUKTCODES

## IMBALLI packing / emballage / Verpackung

ARTICOLO	SCATOLA				PALLET			
	cm	inch	pz.	m <sup>2</sup>	kg	scat.	m <sup>2</sup>	kg
fondo	58x116	23"x46"	2	1,35	31,5	36	48,4	1134,0
fondo	60x120	24"x48"	2	1,44	35,5	36	51,8	1278,0
fondo	75x75	30"x30"	2	1,13	27,4	42	47,3	1150,8
fondo	73x73	29"x29"	2	1,07	26,3	42	44,8	1105,0
fondo	60x60	24"x24"	4	1,44	32,5	32	46,1	1040,0
fondo	30x60	12"x24"	8	1,44	32,5	32	46,1	1040,0
decoro scraps	60x60	24"x24"	4	1,44	32,5	32	46,1	1040,0
mosaico basic	30x30	12"x12"	4	0,36	8,4	60	21,6	501,0
battiscopa	10x60	4"x24"	12	7,2 m.l.	16,7	60	432,0 m.l.	1002,0
gradino plus	35x60	13 <sup>3/4</sup> "x24"	4	0,84	21,4	16	13,4	342,4
angolo gradino plus	35x35	13 <sup>3/4</sup> "x13 <sup>3/4</sup> "	2	0,25	6,7	36	8,8	241,2
raccordo jolly	1,3x30	1/2"x12"	16	0,06	1,3	322	20,1	412,2
beak jolly	1,3x2	1/2"x3/4"	4	-	0,1	700	0,7	42,0

# GOCCIA design Kravitz Design Inc.

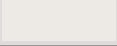
## FONDI plain tiles / fonds / Unifliesen

			<b>mood 14</b> <b>10x40cm</b> <b>4"x16"</b>						
			<b>nat</b>						
			<b>9mm</b>						
<b>XWhite</b>		<b>GLOSSY</b>	LPDPTX0						
<b>XBlack</b>		<b>GLOSSY</b>	LPDPTW0						
<b>Gesso</b>		<b>MATT</b>	LPDPTI0						
			<b>SINGLE TUNE IN</b>	<b>SINGLE TUNE OUT</b>	<b>DOUBLE TUNE IN</b>	<b>DOUBLE TUNE OUT</b>	<b>TUNE IN</b>	<b>TUNE OUT</b>	<b>DISTORTION</b>
			<b>10x40cm</b> <b>4"x16"</b>	<b>10x40cm</b> <b>4"x16"</b>	<b>10x40cm</b> <b>4"x16"</b>	<b>10x40cm</b> <b>4"x16"</b>	<b>13x13cm</b> <b>5<sup>1/8</sup>"x5<sup>1/8</sup>"</b>	<b>13x13cm</b> <b>5<sup>1/8</sup>"x5<sup>1/8</sup>"</b>	<b>13x13cm</b> <b>5<sup>1/8</sup>"x5<sup>1/8</sup>"</b>
			<b>nat</b>	<b>nat</b>	<b>nat</b>	<b>nat</b>	<b>nat</b>	<b>nat</b>	<b>nat</b>
			<b>9mm</b>	<b>9mm</b>	<b>9mm</b>	<b>9mm</b>	<b>9mm</b>	<b>9mm</b>	<b>9mm</b>
<b>White</b>		<b>GLOSSY</b>	LPDGE01	LPDGE00	LPDGE06	LPDGE05	LPIGE01	LPIGE00	LPIGE0D
		<b>MATT</b>	LPDGE21	LPDGE20	LPDGE26	LPDGE25	LPIGE21	LPIGE20	-
<b>Black</b>		<b>GLOSSY</b>	LPDGE11	LPDGE10	LPDGE16	LPDGE15	LPIGE11	LPIGE10	LPIGE1D
		<b>MATT</b>	LPDGE31	LPDGE30	LPDGE36	LPDGE35	LPIGE31	LPIGE30	-















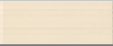

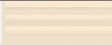

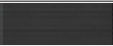

## IMBALLI packing / emballage / Verpackung

ARTICOLO	SCATOLA				PALLET			
	cm	inch	pz.	m <sup>2</sup>	kg	scat.	m <sup>2</sup>	kg
tune	13x13	5 <sup>1/8</sup> "x5 <sup>1/8</sup> "	10	0,17	3,5	80	13,5	280,0
distorsion	13x13	5 <sup>1/8</sup> "x5 <sup>1/8</sup> "	10	0,17	3,5	80	13,5	280,0
double tune	10x40	4"x16"	4	0,16	3,2	72	11,5	230,4
single tune	10x40	4"x16"	4	0,16	3,2	72	11,5	230,4

## GRES AND MORE

## LINK

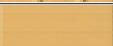
## FONDI plain tiles / fonds / Unifliesen

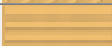
		20x20cm 8"x8"		30x30cm 12"x12"			
		9 mm		9 mm			
Bianco	bolli sfalsati 13		LGHLKT0	Bianco	bolli sfalsati		LG901BS
	bolli sfalsati 12		LGHLKD0		curva mista		LGPLKM0
	righe		LGHLKR0		curva diagonale		LGPLKC0
	borchie		LGHLKB0		rettilineo		LGPLKR0
Nero	bolli sfalsati 13		LGHLKT2	Nero	bolli sfalsati		LG9LK20
	bolli sfalsati 12		LGHLKD2		curva mista		LGPLKM2
	righe		LGHLKR2		curva diagonale		LGPLKC2
	borchie		LGHLKB2		rettilineo		LGPLKR2
Giallo	bolli sfalsati 13		LGHLKT1	Giallo	bolli sfalsati		LG9LK10
	bolli sfalsati 12		LGHLKD1		curva mista		LGPLKM1
	righe		LGHLKR1		curva diagonale		LGPLKC1
	borchie		LGHLKB1		rettilineo		LGPLKR1

## IMBALLI packing / emballage / Verpackung

ARTICOLO	SCATOLA			PALLET				
	cm	inch	pz.	mq	kg	scat.	mq	kg
fondo	30x30	12"x12"	6	0,54	11,3	58	31,3	655,4
fondo bolli sfalsati	20x20	8"x8"	8	0,32	6,8	90	28,8	612,0
fondo borchie - righe	20x20	8"x8"	12	0,48	10,2	90	43,2	918,0

## MAKÒ

## FONDI plain tiles / fonds / Unifliesen

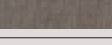
		2x2cm 3/4"x3/4"	2x60cm 3/4"x24"	9,7x60cm 3 3/4"x24"	30x60cm 12"x24"	60x60cm 24"x24"
		rett	rett	rett	rett	rett
		11 mm	11 mm	11 mm	11 mm	11 mm
Papiro Bianco		LG9MK35	LG9MK30	LG9MK00	LGVMKR0	LGWMKR0
Linen Beige		LG9MK36	LG9MK31	LG9MK01	LGVMKR1	LGWMKR1
Cedar Bruno		LG9MK38	LG9MK33	LG9MK03	LGVMKR3	LGWMKR3
Yucca Grigio		LG9MK37	LG9MK32	LG9MK02	LGVMKR2	LGWMKR2
Java Scuro		LG9MK39	LG9MK34	LG9MK04	LGVMKR4	LGWMKR4





# LEGENDA CODICI PRODOTTO

LEGEND PRODUCT CODES

LÉGENDE CODES PRODUITS

LEGEND PRODUKTCODES

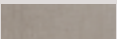
## DECORI decors / articles / Dekore

	PIN STRIPED	CORSET	CROSS	TARTAN	WALLFLOWER
	30x60cm 12"x24"	30x30cm 12"x12"	30x60cm 12"x24"	30x60cm 12"x24"	30x60cm 12"x24"
<b>Papiro Bianco</b> 	LG9MK23	LG9MK16	-	-	LG9MK05
<b>Linen Beige</b> 	LG9MK24	LG9MK17	LG9MK10	-	LG9MK06
<b>Cedar Bruno</b> 	LG9MK27	LG9MK20	-	LG9MK13	LG9MK09
<b>Yucca Grigio</b> 	LG9MK25	LG9MK18	LG9MK11	-	LG9MK07
<b>Java Scuro</b> 	LG9MK26	LG9MK19	-	LG9MK12	LG9MK08
WALLPAPER GREY	WALLPAPER BEIGE	FASCIA TWILL COLD	FASCIA TWILL WARM	FASCIA BROCADE COLD	FASCIA BROCADE WARM
20x60cm 8"x24"	20x60cm 8"x24"	3x60cm 1 3/16"x24"	3x60cm 1 3/16"x24"	3x60cm 1 3/16"x24"	3x60cm 1 3/16"x24"
LG9MK14	LG9MK15	LG9MK41	LG9MK40	LG9MK22	LG9MK21

## PEZZI SPECIALI trims / pièces spéciales / Formstücke

	Papiro Bianco	Linen Beige	Cedar Bruno	Yucca Grigio	Java Scuro
					
<b>battiscopa</b> 10x60cm / 4"x24" rett	LGBMK00	LGBMK10	LGBMK30	LGBMK20	LGBMK40
<b>gradino step</b> 60x60cm / 24"x24" rett	LGCMKR0	LGCMKR1	LGCMKR3	LGCMKR2	LGCMKR4
<b>raccordo jolly</b> 1,3x30cm / 1/2"x12" rett	LG9MK42	LG9MK43	LG9MK45	LG9MK44	LG9MK46
<b>beak jolly</b> 1,3x1,3cm / 1/2"x1/2" rett	LG9MK47	LG9MK48	LG9MK50	LG9MK49	LG9MK51

## IMBALLI packing / emballage / Verpackung

ARTICOLO	SCATOLA					PALLET		
	cm	inch	pz.	mq	kg	scat.	mq	kg
fondo	60x60	24"x24"	4	1,44	35,0	32	46,1	1120,0
fondo	30x60	12"x24"	8	1,44	34,9	32	46,1	1116,8
fondo	9,7x60	3 3/4"x24"	13	0,76	19,2	60	45,4	1152,0
fondo	2x60	3/4"x24"	12	0,14	3,5	100	14,4	348,0
fondo	2x2	3/4"x3/4"	12	-	-	300	1,4	3,0
decoro pin striped	30x60	12"x24"	4	0,72	17,2	24	17,3	412,8
decoro wallflower	30x60	12"x24"	4	0,72	17,2	48	34,6	825,6
decoro tartan	30x60	12"x24"	4	0,72	17,2	48	34,6	825,6
decoro cross	30x60	12"x24"	4	0,72	17,2	30	21,6	516,0
decoro wallpaper	20x60	8"x24"	4	0,48	11,4	60	28,8	686,4
decoro corset	30x30	12"x12"	6	0,54	13,1	35	18,9	457,8
fascia brocade	3x60	1 3/16"x24"	12	0,22	5,2	100	21,6	516,0
fascia twill	3x60	1 3/16"x24"	10	0,18	7,5	100	18,0	753,0
battiscopa	10x60	4"x24"	12	7,2 m.l.	18,0	55	396,0 m.l.	990,0
gradino step	60x60	24"x24"	4	1,44	35,0	24	34,6	840,0
beak jolly	1,3x1,3	1/2"x1/2"	4	-	-	-	-	-
raccordo jolly	1,3x30	1/2"x12"	8	-	0,3	-	-	-

## GRES AND MORE

## METROPOLIS

## FONDI plain tiles / fonds / Unifliesen

			30×60cm	60×60cm	45×90cm	90×90cm
			12"×24"	24"×24"	18"×36"	36"×36"
			rett	rett	rett	rett
			10 mm	10 mm	11 mm	11 mm
Tokyo White		NAT	LGVML10	LGWML1R	-	-
		TEXT	-	-	LGGML10	LG9ML10
		TEXT GRIP	LGVML16	LGWML16	-	-
Paris Amande		NAT	LGVML30	LGWML3R	-	-
		TEXT	-	-	LGGML30	LG9ML30
		TEXT GRIP	-	-	-	-
Milano Ecrú		NAT	LGVML20	LGWML2R	-	-
		TEXT	-	-	LGGML20	LG9ML20
		TEXT GRIP	LGVML26	LGWML26	-	-
Rio Coffee		NAT	LGVML00	LGWML0R	-	-
		TEXT	-	-	LGGML00	LG9ML00
		TEXT GRIP	LGVML06	LGWML06	-	-
London Gray		NAT	LGVML60	LGWML6R	-	-
		TEXT	-	-	LGGML60	LG9ML60
		TEXT GRIP	-	-	-	-
Shanghai Iron		NAT	LGVML50	LGWML5R	-	-
		TEXT	-	-	LGGML50	LG9ML50
		TEXT GRIP	LGVML56	LGWML56	-	-
New York Coal		NAT	LGVML40	LGWML4R	-	-
		TEXT	-	-	LGGML40	LG9ML40
		TEXT GRIP	-	-	-	-
Berlin Night		NAT	LGVML70	LGWML7R	-	-
		TEXT	-	-	LGGML70	LG9ML70
		TEXT GRIP	-	-	-	-

## DECORI E MOSAICI decors and mosaics / décors et mosaïques / Dekore und Mosaik

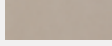
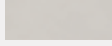
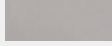
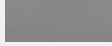
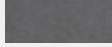
		MURETTO AVENUE 3D	MURETTO URBAN COLD	MURETTO URBAN WARM
		30×60cm 12"×24"	30×60cm 12"×24"	30×60cm 12"×24"
Tokyo White		LG9MLM1	LG9MLC0	LG9MLW0
Paris Amande		-		
Milano Ecrú		LG9MLM2		
Rio Coffee		LG9MLM0	BACCHETTA METAL TITANIO	BACCHETTA METAL NERO
London Gray		-	1,5×60cm 5/8"×24"	1,5×60cm 5/8"×24"
Shanghai Iron		LG9MLM5	LG9ML0T	LG9ML0N
New York Coal		-		BACCHETTA METAL MOKA
Berlin Night		LG9MLM7		1,5×60cm 5/8"×24"

# LEGENDA CODICI PRODOTTO

LEGEND PRODUCT CODES

LÉGENDE CODES PRODUITS

LEGEND PRODUKTCODES

	Tokyo White	Paris Amande	Milano Ecrú	Rio Coffee	London Gray	Shanghai Iron	New York Coal	Berlin Night
<b>battiscopa nat.</b> 10x60cm / 13 <sup>3/4</sup> "x24" rett	LGBMLN1	LGBMLN3	LGBMLN2	LGBMLN0	LGBMLN6	LGBMLN5	LGBMLN4	LGBMLN7
<b>gradino plus nat.*</b> 35x60cm / 13 <sup>3/4</sup> "x24" rett	LG9MLG1	LG9MLG3	LG9MLG2	LG9MLG0	LG9MLG6	LG9MLG5	LG9MLG4	LG9MLG7
<b>angolo gradino plus nat.*</b> 35x35cm / 13 <sup>3/4</sup> "x13 <sup>3/4</sup> " rett	LG9MLA1	LG9MLA3	LG9MLA2	LG9MLA0	LG9MLA6	LG9MLA5	LG9MLA4	LG9MLA7
<b>battiscopa texture grip</b> 10x60cm / 4"x24" rett	LGBMLT1	-	LGBMLT2	LGBMLT0	-	LGBMLT5	-	-
<b>gradino plus texture grip*</b> 35x60cm / 13 <sup>3/4</sup> "x24" rett	LG9MLY1	-	LG9MLY2	LG9MLY0	-	LG9MLY5	-	-
<b>angolo gradino plus texture grip*</b> 35x35cm / 13 <sup>3/4</sup> "x13 <sup>3/4</sup> " rett	LG9MLX1	-	LG9MLX2	LG9MLX0	-	LG9MLX5	-	-

\* Su richiesta. Per maggiori informazioni circa quantità minime e tempi di consegna rivolgersi all'ufficio commerciale. / Upon request. For more information about minimum quantities and delivery times please contact the sales department. / Sur demande. Pour plus d'informations sur les quantités minimales et délais de livraison s'il vous plaît contacter le département des ventes. / auf Anfrage. Für weitere Infos über die Mindestmengen und Lieferzeiten wenden Sie sich bitte an unserer Verkaufsabteilung.

## IMBALLI packing / emballage / Verpackung





ARTICOLO	SCATOLA				PALLET			
	cm	inch	pz.	mq	kg	scat.	mq	kg
fondo	90x90	36"x36"	2	1,62	40,0	30	48,6	1200,0
fondo	45x90	18"x36"	3	1,22	30,0	30	36,5	900,0
fondo	60x60	24"x24"	4	1,44	32,5	32	46,1	1040,0
fondo	30x60	12"x24"	8	1,44	32,5	32	46,1	1040,0
muretto urban	30x60	12"x24"	4	0,72	15,6	30	21,6	468,0
muretto avenue 3D	30x60	12"x24"	4	0,72	18,2	30	21,6	546,0
bacchetta metal	1,5x60	5/8"x24"	15	0,14	4,5	100	13,5	450,0
battiscopa	10x60	4"x24"	12	7,2 m.l.	18,0	50	360,0 m.l.	900,0
gradino plus	35x60	13 <sup>3/4</sup> "x24"	4	0,84	21,2	16	13,4	339,2
angolo gradino plus	35x35	13 <sup>3/4</sup> "x13 <sup>3/4</sup> "	2	0,25	6,7	36	8,8	241,2



## GRES AND MORE

## NEXTONE

## FONDI plain tiles / fonds / Unfliesen

			Gamma 72					
			30×60cm 12"×24"	60×60cm 24"×24"	60×120cm 24"×48"	49,8×16,9cm 19 <sup>1/2</sup> "×6 <sup>5/8</sup> "	60×60cm 24"×24"	60×120cm 24"×48"
			rett	rett	rett	rett	rett	rett
			10 mm	10 mm	10 mm	10 mm	20 mm SYSTEM L2	20 mm SYSTEM L2
Next White		NAT	LGVN30	LGWN30	LGXN30	LGZNX03	-	-
		LAPP	LGVNXL3	LGWNXL3	LGXNXL3	-	-	-
		GRIP	-	LGWN35	-	-	LGWNX93	LGXNX63
		DOT	LGVN53	LGWN53	-	-	-	-
		LINE	LGVN63	LGWN63	-	-	-	-
Next Gray		NAT	LGVN10	LGWN10	LGXN10	LGZNX01	-	-
		LAPP	LGVNXL1	LGWNXL1	LGXNXL1	-	-	-
		GRIP	-	LGWN15	-	-	LGWNX91	LGXNX61
		DOT	LGVN51	LGWN51	-	-	-	-
		LINE	LGVN61	LGWN61	-	-	-	-
Next Taupe		NAT	LGVN20	LGWN20	LGXN20	LGZNX02	-	-
		LAPP	LGVNXL2	LGWNXL2	LGXNXL2	-	-	-
		GRIP	-	LGWN05	-	-	LGWNX92	LGXNX62
		DOT	LGVN52	LGWN52	-	-	-	-
		LINE	LGVN62	LGWN62	-	-	-	-
Next Dark		NAT	LGVN00	LGWN00	LGXN00	LGZNX00	-	-
		LAPP	LGVNXL0	LGWNXL0	LGXNXL0	-	-	-
		GRIP	-	LGWN05	-	-	LGWNX90	LGXNX60
		DOT	LGVN50	LGWN50	-	-	-	-
		LINE	LGVN60	LGWN60	-	-	-	-
		MARK	LGVN70	LGWN70	-	-	-	-

## MOSAICI mosaics / mosaïques / Mosaik

		Next White	Next Gray	Next Taupe	Next Dark
					
MURETTO 30×60cm 12"×24"	NAT	LG9NX03	LG9NX01	LG9NX02	LG9NX00
MOSAICO MIX* 30×30cm 12"×12"	NAT	LG9NX23	LG9NX21	LG9NX22	LG9NX20
MOSAICO 144 30×30cm 12"×12"	NAT	LG9NX13	LG9NX11	LG9NX12	LG9NX10

\*superfici mixate: nat + dot + line + mark / superfici mixate: nat + dot + line + mark / superficies mixtes: nat + dot + line + mark / gemischte Oberflächen: nat + dot + line + mark / superfici mixate: nat + dot + line + mark

# LEGENDA CODICI PRODOTTO

LEGEND PRODUCT CODES

LÉGENDE CODES PRODUITS

LEGEND PRODUKTCODES

## PEZZI SPECIALI trims / pièces spéciales / Formstücke

		Next White 	Next Gray 	Next Taupe 	Next Dark 
<b>battiscopa</b> 5,5x60cm / 2 <sup>11/64</sup> "x24" rett	LAPP	LGRNXL3	LGRNXL1	LGRNXL2	LGRNXL0
	NAT	LGRNX30	LGRNX10	LGRNX20	LGRNX00
<b>gradino plus*</b> 35x120cm / 13 <sup>3/4</sup> "x48" rett	LAPP	LGDNX80	LGDNX60	LGDNX70	LGDNX50
	NAT	LGDNX30	LGDNX10	LGDNX20	LGDNX00
<b>angolo dx gradino plus*</b> 35x120cm / 13 <sup>3/4</sup> "x48" rett	LAPP	LGDNX81	LGDNX61	LGDNX71	LGDNX51
	NAT	LGDNX31	LGDNX11	LGDNX21	LGDNX01
<b>angolo sx gradino plus*</b> 35x120cm / 13 <sup>3/4</sup> "x48" rett	LAPP	LGDNX82	LGDNX62	LGDNX72	LGDNX52
	NAT	LGDNX32	LGDNX12	LGDNX22	LGDNX02
<b>gradino plus*</b> 35x60cm / 13 <sup>3/4</sup> "x24" rett	GRIP	LG9NXG3	LG9NXG1	LG9NXG2	LG9NXG0
<b>angolo gradino plus*</b> 35x60cm / 13 <sup>3/4</sup> "x24" rett	GRIP	LG9NX03	LG9NX01	LG9NX02	LG9NX00

\* Su richiesta. Per maggiori informazioni circa quantità minime e tempi di consegna rivolgersi all'ufficio commerciale. / Upon request. For more information about minimum quantities and delivery times please contact the sales department. / Sur demande. Pour plus d'informations sur les quantités minimales et délais de livraison s'il vous plaît contacter le département des ventes. / auf Anfrage. Für weitere Infos über die Mindestmengen und Lieferzeiten wenden Sie sich bitte an unserer Verkaufsabteilung.



## IMBALLI packing / emballage / Verpackung

ARTICOLO	SCATOLA					PALLET		
	cm	inch	pz.	m <sup>q</sup>	kg	scat.	m <sup>q</sup>	kg
fondo	30x60	23"x46"	8	1,44	32,5	32	46,1	1040,0
fondo	60x60	24"x48"	4	1,44	32,5	32	46,1	1040,0
fondo	60x120	29"x29"	2	1,44	35,5	36	51,8	1278,0
fondo gramma 72	49,8x14,5	19 <sup>1/2</sup> "x5 <sup>45/64</sup> "	14	1,01	23,0	32	32,3	736,0
muretto	30x60	12"x24"	4	0,72	15,6	30	21,6	468,0
mosaico 36	30x30	12"x12"	5	0,45	10,0	60	27,0	600,0
mosaico 144	30x30	12"x12"	5	0,45	10,0	60	27,0	600,0
battiscopa	5,5x60	2 <sup>11/64</sup> "x24	12	7,2 m.l.	16,7	60	432,0 m.l.	1002,0
gradino plus	35x120	13 <sup>3/4</sup> "x48"	2	0,84	23,2	16	13,4	371,2
angolo gradino plus	35x120	13 <sup>3/4</sup> "x48"	1	0,42	12,4	16	6,7	198,4
gradino plus	35x60	13 <sup>3/4</sup> "x24"	4	0,84	21,4	16	13,4	342,4
angolo gradino plus	35x35	13 <sup>3/4</sup> "x13 <sup>3/4</sup> "	2	0,25	6,7	36	8,8	241,2

## GRES AND MORE

## STONECLAY

## FONDI plain tiles / fonds / Unifliesen

		30x60cm 12"x24"	60x60cm 24"x24"	60,4x60,4cm 24"x24"	60x60cm 24"x24"
		rett	rett	nat	rett
		10 mm	10 mm	10 mm	20 mm - SYSTEM L2
<b>Silt</b>		-	-	LGWSY30	-
		LGVSyr3	LGWSYR3	-	-
<b>Lime</b>		-	-	LGWSY10	-
		LGVSyr1	LGWSYR1	-	LGWK201
<b>Cendre</b>		-	-	LGWSY20	-
		LGVSyr2	LGWSYR2	-	LGWK211
<b>Charcoal</b>		-	-	LGWSY00	-
		LGVSyr0	LGWSYR0	-	-

## MOSAICI mosaics / mosaïques / Mosaik

		MOSAICO	
		30x30cm 12"x12"	
<b>Silt</b>		LG9SYM3	
<b>Lime</b>		LG9SYM1	
<b>Cendre</b>		LG9SYM2	
<b>Charcoal</b>		LG9SYM0	

## PEZZI SPECIALI trims / pièces spéciales / Formstücke

	SILT	LIME	CENDRE	CHARCOAL
				
<b>battiscopa</b> 10x60cm / 4"x24" rett	LGBSY30	LGBSY10	LGBSY20	LGBSY00
<b>gradino step</b> 60x60cm / 24"x24" rett	LGCSY30	LGCSY10	LGCSY20	LGCSY00

## IMBALLI packing / emballage / Verpackung

ARTICOLO	SCATOLA			PALLET				
	cm	inch	pz.	mq	kg	scat.	mq	kg
fondo	60,4x60,4	24"x24"	4	1,46	33,5	32	46,7	1070,4
fondo	60x60	24"x24"	4	1,44	32,5	32	46,1	1040,0
fondo	30x60	12"x24"	8	1,44	32,5	32	46,1	1040,0
mosaico	30x30	12"x12"	5	0,45	9,3	60	27,0	558,0
battiscopa	10x60	4"x24"	12	7,2 m.l.	16,0	60	432 m.l.	960,0
gradino step	60x60	24"x24"	4	1,44	32,0	32	46,1	1024,0

# LEGENDA CODICI PRODOTTO











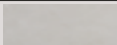
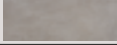
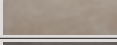
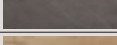

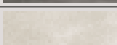
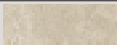

LEGEND PRODUCT CODES

LÉGENDE CODES PRODUITS

LEGEND PRODUKTCODES

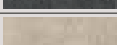
## SYSTEM L2

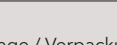
### FONDI plain tiles / fonds / Unifliesen



		30x120cm	45x90cm	60x60cm	60x120cm
		12"x48"	18"x36"	24"x24"	24"x48"
		rett	rett	rett	rett
		20 mm	20 mm	20 mm	20 mm
Next White L2		.	.	LGWNX93	LGXNX63
Next Gray L2		.	.	LGWNX91	LGWNX61
Next Taupe L2		.	.	LGWNX92	LGWNX62
Next Dark L2		.	.	LGWNX90	LGWNX60
Lodge Grove L2		LG6K235	.	-	.
Lodge Brown L2		LG6K205	.	-	.
Lodge Greige L2		LG6K215	.	-	.
Lodge Grey L2		LG6K225	.	-	.
White Dover L2		-	-	LGWK287	-
Beige Madeira L2		-	-	LGWK281	-
Taupe Moher L2		-	-	LGWK285	-
Grey Tenerife L2		-	-	LGWK283	-
Ivory Flow L2		-	LGGK220	-	-
Silver Flow L2		-	LGGK230	-	-
Gray Flow L2		-	LGGK210	-	-
Dark Flow L2		-	LGGK200	-	-
Lime L2		-	-	LGWK201	-
Cendre L2		-	-	LGWK211	-

### IMBALLI packing / emballage / Verpackung

ARTICOLO	SCATOLA					PALLET		
	cm	inch	pz.	m <sup>q</sup>	kg	scat.	m <sup>q</sup>	kg
fondo	30x120	12"x48"	2	0,72	33,3	32	23,0	1064,0
fondo	45x90	18"x36"	2	0,81	36,2	24	19,4	869,5
fondo	60x60	24"x24"	2	0,72	33,6	32	23,0	1075,2
costa toro	30x60	12"x24"	1	0,18	8,1	100	18,0	812,5
costa toro angolare	30x60	12"x24"	1	0,14	6,1	100	13,5	610,0
costa retta	30x60	12"x24"	1	0,18	8,1	100	18,0	812,5
costa retta angolare	30x60	12"x24"	1	0,14	6,1	100	13,5	610,0
costa toro step	30x60	12"x24"	1	0,18	8,1	100	18,0	812,5
costa retta step	30x60	12"x24"	1	0,18	8,1	100	18,0	812,5
costa toro con gocc.	30x60	12"x24"	1	0,18	8,1	100	18,0	812,5
costa retta con gocc.	30x60	12"x24"	1	0,18	8,1	100	18,0	812,5
griglia	15x60	6"x24"	2	0,18	8,0	100	18,0	800,0
griglia angolare	15x60	6"x24"	2	0,16	7,0	100	15,8	700,0

## GRES AND MORE

## PEZZI SPECIALI trims / pièces spéciales / Formstücke

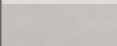
	WATERFALL					NEXTONE			
	IVORY FLOW L2	SILVER FLOW L2	GRAY FLOW L2	DARK FLOW L2		NEXT WHITE L2	NEXT GRAY L2	NEXT TAUPE L2	NEXT DARK L2
									
<b>griglia*</b> 15x45cm / 6"x18" rett	LGDK2Z2	LGDK2Z3	LGDK2Z1	LGDK2Z0	<b>griglia*</b> 15x60cm / 6"x24" rett	LG1NX30	LG1NX10	LG1NX20	LG1NX00
<b>griglia angolare dx*</b> 15x45cm / 6"x18" rett	LGDK2A4	LGDK2A6	LGDK2A2	LGDK2A0	<b>griglia angolare dx*</b> 15x60cm / 6"x24" rett	LG1NX32	LG1NX12	LG1NX22	LG1NX02
<b>gradino angolare sx*</b> 15x45cm / 6"x18" rett	LGDK2A5	LGDK2A7	LGDK2A3	LGDK2A1	<b>gradino angolare sx*</b> 15x60cm / 6"x24" rett	LG1NX31	LG1NX11	LG1NX21	LG1NX01
<b>costa toro*</b> 30x90cm / 12"x36" rett	LGFK2F2	LGFK2F3	LGFK2F1	LGFK2F0	<b>costa toro*</b> 30x60cm / 12"x24" rett	LGDNXF3	LGDNXF1	LGDNXF2	LGDNXF0
<b>costa toro angolare dx*</b> 30x90cm / 12"x36" rett	LGFK2K4	LGFK2K6	LGFK2K2	LGFK2K0	<b>costa toro angolare dx*</b> 30x60cm / 12"x24" rett	LGDNXB7	LGDNXB3	LGDNXB5	LGDNXB1
<b>costa toro angolare sx*</b> 30x90cm / 12"x36" rett	LGFK2K5	LGFK2K7	LGFK2K3	LGFK2K1	<b>costa toro angolare sx*</b> 30x60cm / 12"x24" rett	LGDNXB6	LGDNXB2	LGDNXB4	LGDNXB0
<b>costa retta*</b> 30x90cm / 12"x36" rett	LGFK2C2	LGFK2C3	LGFK2C1	LGFK2C0	<b>costa retta*</b> 30x60cm / 12"x24" rett	LGDNXC3	LGDNXC1	LGDNXC2	LGDNXC0
<b>costa retta angolare dx*</b> 30x90cm / 12"x36" rett	LGFK2D4	LGFK2D6	LGFK2D2	LGFK2D0	<b>costa retta angolare dx*</b> 30x60cm / 12"x24" rett	LGDNXA7	LGDNXA3	LGDNXA5	LGDNXA1
<b>costa retta angolare sx*</b> 30x90cm / 12"x36" rett	LGFK2D5	LGFK2D7	LGFK2D3	LGFK2D1	<b>costa retta angolare sx*</b> 30x60cm / 12"x24" rett	LGDNXA6	LGDNXA2	LGDNXA4	LGDNXA0
<b>costa toro step*</b> 30x90cm / 12"x36" rett	LGFK2J2	LGFK2J3	LGFK2J1	LGFK2J0	<b>costa toro step*</b> 30x60cm / 12"x24" rett	LGDNXJ3	LGDNXJ1	LGDNXJ2	LGDNXJ0
<b>costa retta step*</b> 30x90cm / 12"x36" rett	LGFK2G2	LGFK2G3	LGFK2G1	LGFK2G0	<b>costa retta step*</b> 30x60cm / 12"x24" rett	LGDNXG3	LGDNXG1	LGDNXG2	LGDNXG0
					<b>costa toro con gocciolatoio*</b> 30x60cm / 12"x24" rett	LGDNXH3	LGDNXH1	LGDNXH2	LGDNXH0
					<b>costa retta con gocciolatoio*</b> 30x60cm / 12"x24" rett	LGDNXY3	LGDNXY1	LGDNXY2	LGDNXY0

\* Su richiesta. Per maggiori informazioni circa quantità minime e tempi di consegna rivolgersi all'ufficio commerciale. / Upon request. For more information about minimum quantities and delivery times please contact the sales department. / Sur demande. Pour plus d'informations sur les quantités minimales et délais de livraison s'il vous plaît contacter le département des ventes. / auf Anfrage. Für weitere Infos über die Mindestmengen und Lieferzeiten wenden Sie sich bitte an unserer Verkaufsabteilung.











# LEGENDA CODICI PRODOTTO

LEGEND PRODUCT CODES

LÉGENDE CODES PRODUITS

LEGEND PRODUKTCODES

## PEZZI SPECIALI trims / pièces spéciales / Formstücke

	STONECLAY		BIO LUMBER				CLIFFSTONE			
	LIME L2	CENDRE L2	LODGE GROVE L2	LODGE BROWN L2	LODGE GREIGE L2	LODGE GREY L2	WHITE DOVER L2	BEIGE MADEIRA L2	TAUPE MOHER L2	GREY TENERIFE L2
<b>griglia*</b> 15x60cm / 6"x24" rett										
<b>griglia*</b> 15x60cm / 6"x24" rett	LG1K2G0	LG1K2G1	LG1K219	LG1K203	LG1K204	LG1K220	LG1K221	LG1K222	LG1K223	LG1K224
<b>griglia angolare dx*</b> 15x60cm / 6"x24" rett	LG1K2D0	LG1K2D1	LG1K217	LG1K208	LG1K209	LG1K218	LG1K225	LG1K227	LG1K229	LG1K230
<b>gradino angolare sx*</b> 15x60cm / 6"x24" rett	LG1K2S0	LG1K2S1	LG1K215	LG1K213	LG1K214	LG1K216	LG1K226	LG1K228	LG1K231	LG1K232
<b>costa toro*</b> 30x60cm / 12"x24" rett	LGVK2F0	LGVK2F1	LGVK258	LGVK228	LGVK229	LGVK259	LGVK278	LGVK279	LGVK280	LGVK281
<b>costa toro angolare dx*</b> 30x60cm / 12"x24" rett	LGVK2Y0	LGVK2Y1	LGVK254	LGVK213	LGVK214	LGVK255	LGVK2B0	LGVK2B3	LGVK2B5	LGVK2B7
<b>costa toro angolare sx*</b> 30x60cm / 12"x24" rett	LGVK2K0	LGVK2K1	LGVK256	LGVK208	LGVK209	LGVK257	LGVK2B1	LGVK2B4	LGVK2B6	LGVK2B8
<b>costa retta*</b> 30x60cm / 12"x24" rett	LGVK2C0	LGVK2C1	LGVK260	LGVK203	LGVK204	LGVK261	LGVK290	LGVK291	LGVK292	LGVK293
<b>costa retta angolare dx*</b> 30x60cm / 12"x24" rett	LGVK2E0	LGVK2E1	LGVK250	LGVK223	LGVK224	LGVK251	LGVK2A0	LGVK2A3	LGVK2A5	LGVK2A7
<b>costa retta angolare sx*</b> 30x60cm / 12"x24" rett	LGVK2D0	LGVK2D1	LGVK252	LGVK218	LGVK219	LGVK253	LGVK2A1	LGVK2A4	LGVK2A6	LGVK2A8
<b>costa toro step*</b> 30x60cm / 12"x24" rett	LGVK2J0	LGVK2J1	LGVK268	LGVK238	LGVK239	LGVK269	LGVK270	LGVK271	LGVK272	LGVK273
<b>costa retta step*</b> 30x60cm / 12"x24" rett	LGVK2G0	LGVK2G1	LGVK264	LGVK233	LGVK234	LGVK265	LGVK286	LGVK287	LGVK288	LGVK289
<b>costa toro con gocciolatoio*</b> 30x60cm / 12"x24" rett	LGVK2L0	LGVK2L1	LGVK266	LGVK243	LGVK244	LGVK267	LGVK274	LGVK275	LGVK276	LGVK277
<b>costa retta con gocciolatoio*</b> 30x60cm / 12"x24" rett	LGVK2M0	LGVK2M1	LGVK262	LGVK248	LGVK249	LGVK263	LGVK282	LGVK283	LGVK284	LGVK285

\* Su richiesta. Per maggiori informazioni circa quantità minime e tempi di consegna rivolgersi all'ufficio commerciale. / Upon request. For more information about minimum quantities and delivery times please contact the sales department. / Sur demande. Pour plus d'informations sur les quantités minimales et délais de livraison s'il vous plaît contacter le département des ventes. / auf Anfrage. Für weitere Infos über die Mindestmengen und Lieferzeiten wenden Sie sich bitte an unserer Verkaufsabteilung.

## GRES AND MORE

## TECNOQUARTZ

## FONDI plain tiles / fonds / Unifliesen

		20x30cm	30x30cm	20x60cm	30x60cm	40x60cm	60x60cm
		8"x12"	12"x12"	8"x24"	12"x24"	16"x24"	24"x24"
		rett	rett	rett	rett	rett	rett
		12 mm	12 mm	12 mm	12 mm	12mm	12 mm
<b>Doral</b>		LGHTQ00	LGCTQ00	LGKTQ00	LGVTQ00	LGJTQ01	LGWTQ01
<b>Silver</b>		LGHTQ10	LGCTQ10	LGKTQ10	LGVTQ10	LGJTQ11	LGWTQ11
<b>Gneiss</b>		LGHTQ20	LGCTQ20	LGKTQ20	LGVTQ20	LGJTQ21	LGWTQ21
<b>Hard black</b>		LGHTQ30	LGCTQ30	LGKTQ30	LGVTQ30	LGJTQ31	LGWTQ31

## IMBALLI packing / emballage / Verpackung

ARTICOLO	SCATOLA					PALLET		
	cm	inch	pz.	m <sup>2</sup>	kg	scat.	m <sup>2</sup>	kg
fondo	60x60	24"x24"	4	1,44	36,6	24	34,6	879,4
fondo	40x60	16"x24"	4	0,96	24,6	24	23,0	589,4
fondo	30x60	12"x24"	7	1,26	32,5	32	40,3	1040,0
fondo	20x60	8"x24"	7	0,84	21,2	48	40,3	1017,6
fondo	30x30	12"x12"	12	1,08	27,2	40	43,2	1089,6
fondo	20x30	8"x12"	12	0,72	17,8	60	43,2	1065,6
antico 14	14,5x14,5	5 <sup>3/4</sup> "x5 <sup>3/4</sup> "	31	0,65	17,5	64	41,7	1120,0
antico 7x14	7,1x14,5	2 <sup>3/4</sup> "x5 <sup>3/4</sup> "	62	0,64	17,5	64	40,9	1120,0
listone link	30x60	12"x24"	4	0,72	17,9	40	28,8	716,0
mosaico antico 7	29,3x29,3	11 <sup>1/2</sup> "x11 <sup>1/2</sup> "	5	0,43	10,5	60	25,8	630,0
muretto	30x60	12"x24"	4	0,72	17,9	30	21,6	537,0
battiscopa	8x30	3 <sup>1/8</sup> "x12"	22	5,3 m.l.	15,8	77	407,0 m.l.	1219,7
gradino plus	35x60	13 <sup>3/4</sup> "x24"	4	0,84	25,6	16	13,4	409,6
ang. gradino plus	35x35	13 <sup>3/4</sup> "x13 <sup>3/4</sup> "	2	0,25	8,0	36	8,8	288,0
raccordo jolly	1,2x30	1/2"x12"	8	0,03	0,3	-	-	-
beak jolly	1,2x1,3	1/2"x1/2"	4	-	-	-	-	-

## MOSAICI mosaics / mosaïques / Mosaik

		Listone Link	Muretto	Mosaico Anti. 7	Antico 14	Antico 7x14
		30x60cm 12"x24"	30x60cm 12"x24"	29,3x29,3cm 11 <sup>1/2</sup> "x11 <sup>1/2</sup> "	14,5x14,5cm 5 <sup>3/4</sup> "x5 <sup>3/4</sup> "	7,1x14,5cm 2 <sup>3/4</sup> "x5 <sup>3/4</sup> "
<b>Doral</b>		LG9TQ39	LG9TQ32	LG9TQ02	LG9TQ04	LG9TQ06
<b>Silver</b>		LG9TQ40	LG9TQ33	LG9TQ03	LG9TQ05	LG9TQ07
<b>Gneiss</b>		LG9TQ38	LG9TQ34	LG9TQ09	LG9TQ28	LG9TQ29
<b>Hard black</b>		LG9TQ45	LG9TQ48	LG9TQ51	LG9TQ46	LG9TQ47

# LEGENDA CODICI PRODOTTO

LEGEND PRODUCT CODES

LÉGENDE CODES PRODUITS

LEGEND PRODUKTCODES





## PEZZI SPECIALI trims / pièces spéciales / Formstücke

	<b>DORAL</b> 	<b>SILVER</b> 	<b>GNEISS</b> 	<b>HARD BLACK</b> 
<b>battiscopa</b> 8x30cm / 3 <sup>1</sup> / <sub>2</sub> "x12" rett	LGBTQ01	LGBTQ11	LGBTQ21	LGBTQ31
<b>gradino plus*</b> 35x60cm / 13 <sup>3</sup> / <sub>4</sub> "x24" rett	LG9TQP0	LG9TQP1	LG9TQP2	LG9TQP3
<b>angolo dx gradino plus*</b> 35x35cm / 13 <sup>3</sup> / <sub>4</sub> "x13 <sup>3</sup> / <sub>4</sub> " rett	LG9TQD0	LG9TQD1	LG9TQD2	LG9TQD3
<b>angolo sx gradino plus*</b> 35x35cm / 13 <sup>3</sup> / <sub>4</sub> "x13 <sup>3</sup> / <sub>4</sub> " rett	LG9TQS0	LG9TQS1	LG9TQS2	LG9TQS3
<b>raccordo jolly</b> 1,2x30cm / 1/2"x12" rett	LG9TQ26	LG9TQ27	LG9TQ31	LG9TQ52
<b>beak jolly</b> 1,2x1,2cm / 1/2"x1/2" rett	LG9TQ24	LG9TQ25	LG9TQ30	LG9TQ44

\* Su richiesta. Per maggiori informazioni circa quantità minime e tempi di consegna rivolgersi all'ufficio commerciale. / Upon request. For more information about minimum quantities and delivery times please contact the sales department. / Sur demande. Pour plus d'informations sur les quantités minimales et délais de livraison s'il vous plaît contacter le département des ventes. / auf Anfrage. Für weitere Infos über die Mindestmengen und Lieferzeiten wenden Sie sich bitte an unserer Verkaufsabteilung.

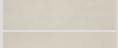
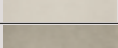
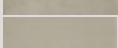
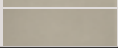
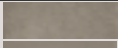
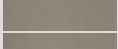
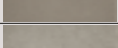
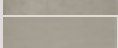
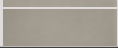
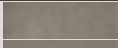
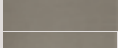
# TRAME

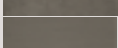
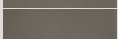
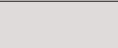
## FONDI plain tiles / fonds / Unifliesen

			gramma 38	gramma 66 sx	gramma 66 dx	cuadra	esa	listello		
			30x90cm 12"x36"	90x90cm 36"x36"	9,7x39,2cm 3 <sup>3</sup> / <sub>4</sub> "x15 <sup>3</sup> / <sub>8</sub> "	16,9x39,2cm 6 <sup>5</sup> / <sub>8</sub> "x15 <sup>3</sup> / <sub>8</sub> "	16,9x39,2cm 6 <sup>5</sup> / <sub>8</sub> "x15 <sup>3</sup> / <sub>8</sub> "	11,2x9,7cm 4 <sup>3</sup> / <sub>8</sub> "x3 <sup>3</sup> / <sub>4</sub> "	9,7x33,8cm 3 <sup>13</sup> / <sub>16</sub> "x13 <sup>3</sup> / <sub>8</sub> "	5x45cm 2"x18"
			rett	rett	rett	rett	rett	rett	rett	rett
			11 mm	11 mm	11 mm	11 mm	11 mm	11 mm	11 mm	11 mm
<b>Lino</b>		<b>PLASTER</b>	LGFT5P2	LG9T5P2	LG8T5P1	LGST5P1	LGDT5P1	LGUT5P1	LGET5P1	LGZT5P2
		<b>MATTER</b>	LGFT5M2	LG9T5M2	LG8T5M1	LGST5M1	LGDT5M1	LGUT5M1	LGET5M1	LGZT5M2
		<b>CANVAS</b>	LGFT5C2	LG9T5C2	LG8T5C1	LGST5C1	LGDT5C1	LGUT5C1	LGET5C1	LGZT5C2
<b>Corda</b>		<b>PLASTER</b>	LGFT5P1	LG9T5P1	LG8T5P2	LGST5P2	LGDT5P2	LGUT5P2	LGET5P2	LGZT5P1
		<b>MATTER</b>	LGFT5M1	LG9T5M1	LG8T5M2	LGST5M2	LGDT5M2	LGUT5M2	LGET5M2	LGZT5M1
		<b>CANVAS</b>	LGFT5C1	LG9T5C1	LG8T5C2	LGST5C2	LGDT5C2	LGUT5C2	LGET5C2	LGZT5C1
<b>Tabacco</b>		<b>PLASTER</b>	LGFT5P4	LG9T5P4	LG8T5P3	LGST5P3	LGDT5P3	LGUT5P3	LGET5P3	LGZT5P4
		<b>MATTER</b>	LGFT5M4	LG9T5M4	LG8T5M3	LGST5M3	LGDT5M3	LGUT5M3	LGET5M3	LGZT5M4
		<b>CANVAS</b>	LGFT5C4	LG9T5C4	LG8T5C3	LGST5C3	LGDT5C3	LGUT5C3	LGET5C3	LGZT5C4
<b>Argilla</b>		<b>PLASTER</b>	LGFT5P0	LG9T5P0	LG8T5P4	LGST5P4	LGDT5P4	LGUT5P4	LGET5P4	LGZT5P0
		<b>MATTER</b>	LGFT5M0	LG9T5M0	LG8T5M4	LGST5M4	LGDT5M4	LGUT5M4	LGET5M4	LGZT5M0
		<b>CANVAS</b>	LGFT5C0	LG9T5C0	LG8T5C4	LGST5C4	LGDT5C4	LGUT5C4	LGET5C4	LGZT5C0
<b>Tortora</b>		<b>PLASTER</b>	LGFT5P5	LG9T5P5	LG8T5P5	LGST5P5	LGDT5P5	LGUT5P5	LGET5P5	LGZT5P5
		<b>MATTER</b>	LGFT5M5	LG9T5M5	LG8T5M5	LGST5M5	LGDT5M5	LGUT5M5	LGET5M5	LGZT5M5
		<b>CANVAS</b>	LGFT5C5	LG9T5C5	LG8T5C5	LGST5C5	LGDT5C5	LGUT5C5	LGET5C5	LGZT5C5
<b>Moro</b>		<b>PLASTER</b>	LGFT5P3	LG9T5P3	LG8T5P6	LGST5P6	LGDT5P6	LGUT5P6	LGET5P6	LGZT5P3
		<b>MATTER</b>	LGFT5M3	LG9T5M3	LG8T5M6	LGST5M6	LGDT5M6	LGUT5M6	LGET5M6	LGZT5M3
		<b>CANVAS</b>	LGFT5C3	LG9T5C3	LG8T5C6	LGST5C6	LGDT5C6	LGUT5C6	LGET5C6	LGZT5C3



## GRES AND MORE

## MOSAICI mosaics / mosaïques / Mosaik

		LINO	CORDA	TABACCO	ARGILLA	TORTORA	MORO	CHIARO	SCURO
<b>arrow</b> 11,2x39,5 cm 4 <sup>13/32"</sup> x13 <sup>35/64"</sup>	PLASTER	LGAT5P1	LGAT5P2	LGAT5P3	LGAT5P4	LGAT5P6	LGAT5P6	-	-
	MATTER	LGAT5M1	LGAT5M2	LGAT5M3	LGAT5M4	LGAT5M6	LGAT5M6	-	-
	CANVAS	LGAT5C1	LGAT5C2	LGAT5C3	LGAT5C4	LGAT5C6	LGAT5C6	-	-
<b>cube</b> 39,5x34,1 cm 13 <sup>35/64"</sup> x11 <sup>27/64"</sup>	TRIMATERICO	LGCT510	LGCT520	LGCT530	LGCT540	LGCT550	LGCT560	-	-
<b>leaf</b> 39,5x34,1 cm 13 <sup>35/64"</sup> x11 <sup>27/64"</sup>	TRIMATERICO	-	-	-	-	-	-	LG9T5LC	LG9T5LS
<b>jewel</b> 33,7x29,7 cm 11 <sup>17/64"</sup> x11 <sup>11/16"</sup>	TRIMATERICO	-	-	-	-	-	-	LG9T5JC	LG9T5JS

## PEZZI SPECIALI trims / pièces spéciales / Formstücke

		LINO	CORDA	TABACCO	ARGILLA	TORTORA	MORO
<b>battiscopa</b> 8x90cm / 3 <sup>1/8"</sup> x36" rett	PLASTER	LGBT5P1	LGBT5P2	LGBT5P3	LGBT5P4	LGBT5P5	LGBT5P6
	MATTER	LGBT5M1	LGBT5M2	LGBT5M3	LGBT5M4	LGBT5M5	LGBT5M6
	CANVAS	LGBT5C1	LGBT5C2	LGBT5C3	LGBT5C4	LGBT5C5	LGBT5C6
<b>gradino plus*</b> 35x45cm / 13 <sup>3/4"</sup> x18" rett	PLASTER	LGGT5P1	LGGT5P2	LGGT5P3	LGGT5P4	LGGT5P5	LGGT5P6
	MATTER	LGGT5M1	LGGT5M2	LGGT5M3	LGGT5M4	LGGT5M5	LGGT5M6
	CANVAS	LGGT5C1	LGGT5C2	LGGT5C3	LGGT5C4	LGGT5C5	LGGT5C6
<b>angolo gradino plus*</b> 35x35cm / 13 <sup>3/4"</sup> x13 <sup>3/4"</sup> rett	PLASTER	LG3T5P1	LG3T5P2	LG3T5P3	LG3T5P4	LG3T5P5	LG3T5P6
	MATTER	-	-	-	-	-	-
	CANVAS	LG3T5C1	LG3T5C2	LG3T5C3	LG3T5C4	LG3T5C5	LG3T5C6
<b>angolo sx gradino plus*</b> 35x35cm / 13 <sup>3/4"</sup> x13 <sup>3/4"</sup> rett	PLASTER	-	-	-	-	-	-
	MATTER	LG2T5M1	LG2T5M2	LG2T5M3	LG2T5M4	LG2T5M5	LG2T5M6
	CANVAS	-	-	-	-	-	-
<b>angolo dx gradino plus*</b> 35x35cm / 13 <sup>3/4"</sup> x13 <sup>3/4"</sup> rett	PLASTER	-	-	-	-	-	-
	MATTER	LG1T5M1	LG1T5M2	LG1T5M3	LG1T5M4	LG1T5M5	LG1T5M6
	CANVAS	-	-	-	-	-	-

## IMBALLI packing / emballage / Verpackung

ARTICOLO	SCATOLA		PALLET					
	cm	inch	pz.	mq	kg	scat.	mq	kg
fondo	90x90	36"x36"	2	1,62	40,0	30	48,6	1200,0
fondo	30x90	12"x36"	3	0,81	20,0	27	21,9	540,0
fondo gramma 38	39,2x9,7	15 <sup>3/8"</sup> x3 <sup>3/4"</sup>	20	0,76	19,0	30	22,8	570,0
fondo gramma 66 sx	39,2x16,9	15 <sup>3/8"</sup> x6 <sup>5/8"</sup>	10	0,66	16,5	40	26,4	660,0
fondo gramma 66 dx	39,2x16,9	15 <sup>3/8"</sup> x6 <sup>5/8"</sup>	10	0,66	16,5	40	26,4	660,0
fondo listello	45x5	18"x2"	23	0,52	12,8	60	31,1	768,0
fondo esa	33,8x9,7	13 <sup>3/8"</sup> x3 <sup>13/16"</sup>	20	0,32	8,0	42	13,4	336,0
fondo cuadra	11,2x9,7	4 <sup>3/8"</sup> x3 <sup>3/4"</sup>	20	0,22	5,5	100	22,0	276,0
mosaico jewel	33,7x29,7	11 <sup>17/64"</sup> x11 <sup>11/16"</sup>	4	0,41	10,5	36	14,8	378,0
mosaico leaf	39,5x34,1	13 <sup>35/64"</sup> x11 <sup>27/64"</sup>	4	0,55	13,5	22	12,1	297,0
mosaico cube	39,5x34,1	13 <sup>35/64"</sup> x11 <sup>27/64"</sup>	5	0,68	17,0	44	29,7	748,0
mosaico arrow	39,5x11,2	4 <sup>13/32"</sup> x13 <sup>35/64"</sup>	10	0,46	11,5	40	18,4	460,0
battiscopa	8x90	3 <sup>1/8"</sup> x36"	9	0,65	16,5	40	25,9	660,0
gradino plus	35x45	13 <sup>3/4"</sup> x18"	2	0,25	7,4	36	8,8	266,4
ang. gradino plus	35x45	13 <sup>3/4"</sup> x18"	2	0,25	7,4	36	8,8	266,4
ang. sx gradino plus	35x45	13 <sup>3/4"</sup> x18"	2	0,25	7,4	36	8,8	266,4
ang. dx gradino plus	35x45	13 <sup>3/4"</sup> x18"	2	0,25	7,4	36	8,8	266,4

# LEGENDA CODICI PRODOTTO

LEGEND PRODUCT CODES





LÉGENDE CODES PRODUITS

LEGEND PRODUKTCODES

## WATERFALL

### FONDI plain tiles / fonds / Unifliesen

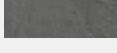
			30×60cm	60×60cm	45×90cm	90×90cm	60×120cm	60×60cm	45×90cm
			12"x24"	24"x24"	18"x36"	36"x36"	24"x48"	24"x24"	18"x36"
			rett	rett	rett	rett	rett	rett	rett
			10,5 mm	10,5 mm	10,5 mm	10,5 mm	10,5 mm	20 mm - SYSTEM L2	20 mm - SYSTEM L2
Ivory flow		NAT	LGWVFN2	LGWVFN2	LGGVFN2	LG9WF20	LGXWF20	-	-
		LAPP	LGWVFX2	LGWVFX2	LGGVFX2	LG9WFX2	LGXWFX2	-	-
		GRIP	-	LGWVFN20	-	-	-	LGWK2W5	LGK220
Silver flow		NAT	LGWVFN3	LGWVFN3	LGGVFN3	LG9WF30	LGXWF30	-	-
		LAPP	LGWVFX3	LGWVFX3	LGGVFX3	LG9WFX3	LGXWFX3	-	-
		GRIP	-	LGWVFN30	-	-	-	LGWVFN36	LGK230
Gray flow		NAT	LGWVFN1	LGWVFN1	LGGVFN1	LG9WF10	LGXWF10	-	-
		LAPP	LGWVFX1	LGWVFX1	LGGVFX1	LG9WFX1	LGXWFX1	-	-
		GRIP	-	LGWVFN10	-	-	-	LGWK2W3	LGK210
Dark flow		NAT	LGWVFN0	LGWVFN0	LGGVFN0	LG9WF00	LGXWF00	-	-
		LAPP	LGWVFX0	LGWVFX0	LGGVFX0	LG9WFX0	LGXWFX0	-	-
		GRIP	-	LGWVFN00	-	-	-	LGWK2W1	LGK200



			Gramma 72	Gramma 66 SX	Gramma 66 DX	Gramma 16 SX	Gramma 16 DX
			49.8×14.5cm	39.2×16.9cm	39.2×16.9cm	19.5×8.3cm	19.5×8.3cm
			19 <sup>1/2</sup> "x5 <sup>45/64</sup> "	15 <sup>3/8</sup> "x6 <sup>5/8</sup> "	15 <sup>3/8</sup> "x6 <sup>5/8</sup> "	7 <sup>5/8</sup> "x3 <sup>17/64</sup> "	7 <sup>5/8</sup> "x3 <sup>17/64</sup> "
			rett	rett	rett	rett	rett
			10,5 mm	10,5 mm	10,5 mm	10,5 mm	10,5 mm
Ivory flow		NAT	LGZWF72	LGZWFS2	LGZWFD2	LG0WFS2	LG0WFD2
		LAPP	-	-	-	-	-
		GRIP	-	-	-	-	-
Silver flow		NAT	LGZWF73	LGZWFS3	LGZWFD3	LG0WFS3	LG0WFD3
		LAPP	-	-	-	-	-
		GRIP	-	-	-	-	-
Gray flow		NAT	LGZWF71	LGZWFS1	LGZWFD1	LG0WFS1	LG0WFD1
		LAPP	-	-	-	-	-
		GRIP	-	-	-	-	-
Dark flow		NAT	LGZWF70	LGZWFS0	LGZWFD0	LG0WFS0	LG0WFD0
		LAPP	-	-	-	-	-
		GRIP	-	-	-	-	-

### MOSAICI mosaics / mosaïques / Mosaik

			Muretto	Brick	Muretto 3D	Mosaico 36
			30×60cm	30×60cm	30×60cm	30×30cm
			12"x24"	12"x24"	12"x24"	12"x12"
Ivory flow		NAT	LG9WFM7	LGWVFN25	LGWVFN27	LG9WFM25
		LAPP	LG9WFM2	LGWVFN20	LGWVFN22	LG9WFM20
Silver flow		NAT	LG9WFM8	LGWVFN35	LGWVFN37	LG9WFM35
		LAPP	LG9WFM3	LGWVFN30	LGWVFN32	LG9WFM30
Gray flow		NAT	LG9WFM6	LGWVFN15	LGWVFN17	LG9WFM15
		LAPP	LG9WFM1	LGWVFN10	LGWVFN12	LG9WFM10
Dark flow		NAT	LG9WFM5	LGWVFN05	LGWVFN07	LG9WFM05
		LAPP	LG9WFM0	LGWVFN00	LGWVFN02	LG9WFM00

# GRES AND MORE

## PEZZI SPECIALI trims / pièces spéciales / Formstücke

		<b>Ivory flow</b> 	<b>Silver flow</b> 	<b>Gray flow</b> 	<b>Dark flow</b> 
<b>battiscopa</b> 10x60cm / 4"x24" rett	LAPP	LGBWFL2	LGBWFL3	LGBWFL1	LGBWFL0
	NAT	LGBWFN2	LGBWFN3	LGBWFN1	LGBWFN0
<b>gradino plus*</b> 35x120cm / 13 <sup>3/4</sup> "x48" rett	LAPP	LG8WF70	LG8WF80	LG8WF60	LG8WF50
	NAT	LG8WF20	LG8WF30	LG8WF10	LG8WF00
<b>angolo dx gradino plus*</b> 35x120cm / 13 <sup>3/4</sup> "x48" rett	LAPP	LG8WF71	LG8WF81	LG8WF61	LG8WF51
	NAT	LG8WF21	LG8WF31	LG8WF11	LG8WF01
<b>angolo sx gradino plus*</b> 35x120cm / 13 <sup>3/4</sup> "x48" rett	LAPP	LG8WF72	LG8WF82	LG8WF62	LG8WF52
	NAT	LG8WF22	LG8WF32	LG8WF12	LG8WF02
<b>gradino plus*</b> 35x60cm / 13 <sup>3/4</sup> "x24" rett	GRIP	LG2WF20	LG2WF30	LG2WF10	LG2WF00
<b>angolo gradino plus*</b> 35x60cm / 13 <sup>3/4</sup> "x24" rett	GRIP	LG2WF21	LG2WF31	LG2WF11	LG2WF01

\* Su richiesta. Per maggiori informazioni circa quantità minime e tempi di consegna rivolgersi all'ufficio commerciale. / Upon request. For more information about minimum quantities and delivery times please contact the sales department. / Sur demande. Pour plus d'informations sur les quantités minimales et délais de livraison s'il vous plaît contacter le département des ventes. / auf Anfrage. Für weitere Infos über die Mindestmengen und Lieferzeiten wenden Sie sich bitte an unserer Verkaufsabteilung.

## IMBALLI packing / emballage / Verpackung

ARTICOLO	SCATOLA					PALLET		
	cm	inch	pz.	mq	kg	scat.	mq	kg
fondo	60x120	24"x48"	2	1,44	35,5	36	51,8	1200,0
fondo	90x90	36"x36"	2	1,62	40	30	48,6	1200,0
fondo	45x90	18"x36"	3	1,22	30	30	36,5	900
fondo	60x60	24"x24"	4	1,44	32,5	32	46,1	1040
fondo grip	60x60	24"x24"	4	1,44	33	32	46,1	1056
fondo	30x60	12"x24"	8	1,44	32,5	32	46,1	1040
muretto	30x60	12"x24"	4	0,72	15,6	30	21,6	468
muretto 3D	30x60	12"x24"	4	0,68	18,2	30	20,5	546
brick	30x60	12"x24"	4	0,72	15,6	30	21,6	468
mosaico 36	30x30	12"x12"	5	0,45	10	60	27	600
gramma 72	49.8x14.5	19 <sup>1/2</sup> "x5 <sup>54/64</sup> "	14	1,01	23	32	32,3	736
gramma 66	39.2x16.9	15 <sup>3/8</sup> "x6 <sup>5/8</sup> "	10	0,66	16,5	40	26,4	660
gramma 16	19.5x8.3	7 <sup>5/8</sup> "x3 <sup>17/64</sup> "	14	0,22	5,6	80	17,9	448
battiscopa	10x60	4"x24"	12	7,2 m.l.	16	60	432,0 m.l.	960
gradino plus	35x120	13 <sup>3/4</sup> "x48"	2	0,84	23,2	16	13,4	371,2
angolo gradino plus	35x120	13 <sup>3/4</sup> "x48"	1	0,42	12,4	16	6,7	198,4
gradino plus	35x60	13 <sup>3/4</sup> "x24"	4	0,84	21,2	16	13,4	339,2
angolo gradino plus	35x35	13 <sup>3/4</sup> "x13 <sup>3/4</sup> "	2	0,25	6,7	36	8,8	241,2

## **NOTA RELATIVA AGLI IMBALLI**

Tutti i dati relativi gli imballi indicati nel presente catalogo sono da ritenersi puramente indicativi e potrebbero subire variazioni.

## **NOTA RELATIVA AL PRODOTTO**

Tutte le informazioni relative al prodotto possono subire variazioni in ordine a migliorie dello stesso.

### **INFORMATION REGARDING PACKAGING**

All information regarding packaging in this catalogue are considered purely indicative and subject to change.

### **NOTE INFORMATIVE CONCERNANT LES IMBALLAGES**

Les valeurs des emballages déclarées sur ce catalogue sont purement indicatives et elles pourront être modifiées.

### **KENNZEICHEN FUER DIE VERPACKUNGSEINHEITEN**

Die Angaben diesen Verpackungen sind rein indikativ und koennen veraendert werden.

### **INFORMATION REGARDING PRODUCT**

All product information can be modified in order to improve it.

### **NOTE INFORMATIVE CONCERNANT LE PRODUIT**

Toutes les informations relatives au produit peuvent subir des variations suite à des améliorations de celui-ci.

### **KENNZEICHEN FUER DIE PRODUKTE**

Alle Produktinformationen können geändert werden, um es zu verbessern.

## CONDIZIONI GENERALI DI VENDITA

### 1) Ambito di applicazione

- 1.1 Le presenti condizioni generali di vendita ("CGV") si applicheranno a tutte le forniture di piastrelle in ceramica ("Prodotti") che saranno eseguite nei confronti di qualsiasi cliente ("CLIENTE") da una società o divisione del Gruppo Panariagroup Industrie Ceramiche S.p.A. ("VENDITORE") anche se le CGV non verranno di volta in volta espressamente richiamate, menzionate ovvero espressamente accettate dal CLIENTE.
- 1.2 Accordi in deroga alle presenti CGV saranno efficaci nei confronti di VENDITORE soltanto (i) se contenuti nel "Contratto di Vendita", come definito al successivo paragrafo 3.2, (ii) se contenuti in documenti successivi alla conclusione del Contratto di Vendita ed il cui contenuto sia stato accettato per iscritto da VENDITORE. In ogni caso, anche se presenti deroghe concordate per iscritto, le CGV continueranno ad applicarsi per le parti non espressamente derogate.
- 1.3 In nessun caso VENDITORE sarà vincolato da eventuali condizioni generali di contratto di CLIENTE, neanche qualora esse siano richiamate o riportate negli ordini o in qualsiasi altra documentazione trasmessa a VENDITORE da CLIENTE. Nessun comportamento di VENDITORE potrà essere interpretato o utilizzato al fine di esprimere tacita accettazione di VENDITORE delle condizioni generali di contratto di CLIENTE.
- 1.4 In nessun caso, VENDITORE sarà vincolato da atti e/o azioni dei propri agenti, essendo questi ultimi privi del potere di vincolare il VENDITORE.
- 1.5 Nel caso in cui CLIENTE sia un consumatore, le disposizioni delle presenti CGV non pregiudicheranno i diritti allo stesso spettanti in base alle previsioni di legge relative alle vendite eseguite nei confronti dei consumatori.

### 2) Prodotti – Modifiche

- 2.1 Le rappresentazioni e/o immagini riguardanti i Prodotti riportate in siti internet, brochure, cataloghi, listini prezzi o documenti similari di VENDITORE hanno valore indicativo ed illustrativo. Conseguentemente, esse non rappresentano il risultato estetico finale dei Prodotti. Le caratteristiche tecniche e fisiche nonché le qualità dei Prodotti sono riportate unicamente nei manuali tecnici di VENDITORE. Ogni altro documento riportante le caratteristiche tecniche e fisiche nonché le qualità dei Prodotti ha valore puramente indicativo e non sarà vincolante per VENDITORE.
- 2.2 VENDITORE dichiara che i Prodotti sono conformi alle norme italiane e comunitarie di settore ad essi applicabili. A pena di inefficacia della garanzia di cui all'articolo 7 e di qualsiasi altra garanzia convenzionale e/o legale, ciascun Prodotto dovrà essere utilizzato ed applicato in conformità alle indicazioni di utilizzo di VENDITORE riferite ai Prodotti in questione e riportate nei cataloghi e/o nei manuali tecnici di VENDITORE ovvero diversamente comunicate o rese accessibili da VENDITORE a CLIENTE e, comunque, in conformità alla diligenza richiesta dalla natura dei Prodotti stessi.
- 2.3 È responsabilità di CLIENTE, prima della conclusione del Contratto di Vendita, accertare che i Prodotti siano idonei allo scopo e/o all'uso specifico per il quale intende acquistarli e, inoltre, accertare che i Prodotti medesimi siano conformi alla normativa applicabile nel luogo in cui CLIENTE intende importarli, distribuirli, venderli o farne qualsiasi uso.
- 2.4 VENDITORE, anche dopo la conclusione del Contratto di Vendita, potrà apportare ai Prodotti qualsiasi modifica che esso ritenga necessaria o opportuna, purché non ne alteri le caratteristiche essenziali. Qualora VENDITORE esegua modifiche sostanziali ai Prodotti (ad es. modifiche che interessano: le modalità di installazione, le caratteristiche di intercambiabilità dei Prodotti ecc.) oggetto di un Contratto di Vendita (come definito al successivo paragrafo 3.2), VENDITORE comunicherà per iscritto tale modifica a CLIENTE.
- 2.5 CLIENTE sarà tenuto a rappresentare agli acquirenti dei Prodotti e ai terzi le caratteristiche dei Prodotti nonché le indicazioni d'uso e di applicazione degli stessi, in conformità a quanto rappresentato da VENDITORE. Fermo restando quanto sopra, CLIENTE sarà esclusivamente responsabile per le dichiarazioni effettuate nei confronti dei terzi in relazione ai Prodotti, alle loro caratteristiche e al loro uso e/o applicazione e dovrà tenere VENDITORE indenne e manlevato da qualsiasi danno eventualmente subito da VENDITORE in relazione a o in connessione con tali dichiarazioni di CLIENTE, nel caso in cui le stesse siano false, incomplete e/o inesatte.

### 3) Preventivi – Conclusione del Contratto di Vendita - Tolleranze

- 3.1 I preventivi, verbali o scritti, di VENDITORE non costituiscono proposte contrattuali.
- 3.2 Il contratto di vendita ("Contratto di Vendita") si perfezionerà attraverso:
- a) la trasmissione della offerta da parte di VENDITORE e l'accettazione scritta di tale offerta da parte di CLIENTE senza alcuna modifica all'offerta stessa; oppure
- b) la trasmissione dell'ordine da parte di CLIENTE e l'accettazione scritta di tale ordine da parte di VENDITORE.
- 3.3 Ai fini del precedente paragrafo 3.2, lettera a) i seguenti fatti o atti avranno valore di accettazione scritta della offerta di VENDITORE da parte di CLIENTE:
- a) ricezione e accettazione, da parte di VENDITORE, di una lettera di credito procurata da CLIENTE;
- b) ricezione e accettazione, da parte di VENDITORE, di tutto o di parte del prezzo della fornitura;
- c) ricezione, da parte di VENDITORE, di un ordine di acquisto emesso da CLIENTE. In tal caso, qualsiasi previsione dell'ordine di acquisto di CLIENTE che risulti difforme dalle previsioni della offerta di VENDITORE sarà vincolante nei confronti di VENDITORE solo se specificamente accettata per iscritto da quest'ultimo.
- 3.4 Inoltre, ai fini del precedente paragrafo 3.2, lettera b), nel caso in cui la accettazione di VENDITORE dell'ordine di CLIENTE contenga condizioni differenti rispetto all'ordine formulato da CLIENTE, il Contratto di Vendita si considererà concluso alle condizioni riportate nella conferma d'ordine di VENDITORE, salvo il caso in cui CLIENTE comunichi per iscritto di rifiutare le modifiche riportate nella accettazione dell'ordine di VENDITORE entro 1 (uno) giorno lavorativo dalla ricezione della stessa.
- 3.5 Le forniture comprenderanno esclusivamente quanto indicato nel Contratto di Vendita.
- 3.6 CLIENTE riconosce a VENDITORE i margini di tolleranza quantitativa e/o qualitativa rinvenibili dal Contratto di Vendita o dagli usi o dalla prassi del settore dei Prodotti.

### 4) Imballaggio – Termini di resa – Termini di consegna

- 4.1 I Prodotti saranno imballati ed approntati per la spedizione secondo i sistemi di protezione generalmente adottati da VENDITORE per i Prodotti in questione in considerazione delle modalità di trasporto convenute. Qualora CLIENTE ritenga necessario l'impiego di imballaggi speciali o di protezioni aggiuntive dovrà farne espressa richiesta a VENDITORE, fermo restando che, in tal caso, saranno a carico di CLIENTE tutti i relativi costi.
- 4.2 Salvo diversamente previsto nel Contratto di Vendita, i Prodotti saranno consegnati a CLIENTE in conformità alla regola Incoterms® ICC, ultima versione, Ex-Works (EXW) – stabilimento di VENDITORE indicato nel Contratto di Vendita.
- CLIENTE autorizza VENDITORE a sottoscrivere, in nome e per conto di CLIENTE, tutti i documenti che debbano essere sottoscritti al momento della presa in carico dei Prodotti presso gli stabilimenti di VENDITORE, come, ad esempio, il CMR.
- Nel caso in cui la regola Incoterms® ICC concordata tra le parti preveda che CLIENTE debba curare il trasporto dei Prodotti fuori dall'Italia:
- a) in caso di cessione intra-comunitaria, entro 45 (quarantacinque) giorni dalla ricezione dei Prodotti presso gli stabilimenti di CLIENTE, CLIENTE dovrà trasmettere a VENDITORE un originale o una copia del documento di trasporto internazionale CMR o di altro documento di trasporto, sottoscritti a destinazione da CLIENTE ovvero, in assenza del CMR, una dichiarazione di ricezione dei Prodotti, emessa sulla base del form quale Allegato -1- disponibile per il download all'indirizzo [www.panariagroup.it](http://www.panariagroup.it);
- b) in caso di cessione extra-comunitaria, CLIENTE si impegna a:
- i) presentare la dichiarazione doganale di esportazione (DAU-EX e DAE) ed effettuare l'appuntamento del MRN (Movement Reference Number) presso la dogana del territorio comunitario di uscita dei Prodotti, entro 90 (novanta) giorni dalla data di consegna in Italia dei Prodotti stessi;
- ii) inviare a VENDITORE, entro 90 (novanta) giorni dalla data di consegna, i documenti comprovanti l'esportazione dei Prodotti (dichiarazione di esportazione DAU-EX + DAE + notifica di avvenuta esportazione);
- iii) confermare prontamente per iscritto a VENDITORE l'avvenuta esecuzione delle suddette formalità e a fornirgli ogni ulteriore documento comprovante l'esecuzione delle suddette formalità e l'uscita dei Prodotti dal territorio dell'Unione Europea.
- In caso di inadempienza di CLIENTE a quanto pattuito al presente paragrafo 4.2, VENDITORE avrà il diritto di addebitare immediatamente a CLIENTE l'Imposta sul Valore Aggiunto relativa alla fornitura e connessa alla mancata prova del trasporto dei Prodotti in altro Stato Membro della Comunità Europea o mancato appuramento della esportazione. In ogni caso, CLIENTE terrà indenne e manlevato VENDITORE in relazione al pagamento di tutto quanto eventualmente dovuto da VENDITORE nei confronti dell'Amministrazione Finanziaria, a titolo di sanzioni ed interessi o ad altro titolo, in connessione con la fornitura e la mancata prova del trasporto dei Prodotti in altro Stato Membro della Comunità Europea o al mancato appuramento della esportazione.
- A tal proposito, VENDITORE potrà: (i) compensare qualsiasi importo dovuto da CLIENTE in base al presente paragrafo 4.2 con eventuali crediti maturati da CLIENTE, a qualsiasi titolo, nei confronti di VENDITORE; ovvero (ii) trattenere definitivamente eventuali somme già ricevute da CLIENTE in relazione a Contratti di Vendita ancora da eseguirsi, effettuando una compensazione fra il debito di CLIENTE in base al presente paragrafo 4.2 e tutti i pagamenti già eseguiti da CLIENTE.
- 4.3 VENDITORE eseguirà la consegna dei Prodotti entro il termine previsto nel Contratto di Vendita, anche mediante consegne parziali. Il termine di consegna si intenderà in ogni caso non essenziale né perentorio. Salvo il caso di dolo o colpa grave, VENDITORE non sarà tenuto a corrispondere a CLIENTE alcun indennizzo o risarcimento per eventuali danni diretti o indiretti dovuti al ritardo nella consegna. In nessun caso di ritardo nella consegna dei Prodotti CLIENTE avrà il diritto di risolvere il Contratto di Vendita.
- 4.4 Al momento della ricezione dei Prodotti, CLIENTE avrà l'onere di denunciare danneggiamenti agli imballi e/o eventuali avarie o ammanchi di Prodotti verificatisi durante il trasporto, mediante apposizione di riserva scritta nel documento di trasporto, nonché l'onere di:
- a) far confermare dal vettore, mediante apposita sottoscrizione, l'apposizione della riserva; e
- b) informare immediatamente per iscritto VENDITORE e inviargli copia del suddetto documento entro e non oltre 8 (otto) giorni dalla data di ricezione dei Prodotti.
- In caso contrario, VENDITORE non sarà responsabile per eventuali danneggiamenti, perdite o furti occorsi ai Prodotti durante il trasporto, anche qualora lo stesso sia eseguito con rischio in tutto o in parte a carico di VENDITORE.

### 5) Prezzi – Pagamento – Ritardato pagamento

- 5.1 I Prodotti verranno forniti ai prezzi concordati tra le parti nel Contratto di Vendita o, qualora il Contratto di Vendita non dovesse menzionare alcun prezzo, ai prezzi riportati nel listino prezzi di VENDITORE in vigore al momento della conclusione del Contratto di Vendita. Salvo diversa indicazione scritta, i prezzi dei Prodotti riportati nei listini, nei preventivi e/o nelle offerte di VENDITORE si intendono in Euro, al netto di IVA e per consegne eseguite in conformità alla regola Incoterms® Ex-Works (EXW), stabilimento di VENDITORE indicato nel Contratto di Vendita, ICC, ultima versione. Pertanto, nel caso in cui venga convenuto un diverso termine di resa, l'importo della fattura verrà modificato di conseguenza, includendo in fattura le spese di trasporto e ogni altro onere connesso con il termine di resa concordato tra le parti per la consegna dei Prodotti.
- 5.2 Il pagamento dei Prodotti dovrà essere eseguito da CLIENTE con le modalità e nei tempi indicati nel Contratto di Vendita o diversamente concordati per iscritto tra le parti. I pagamenti si considereranno effettuati da CLIENTE solo nel momento in cui il relativo importo sarà stato accreditato sul conto corrente di VENDITORE. Il pagamento dovrà essere effettuato da CLIENTE in Euro ovvero nella valuta del luogo in cui CLIENTE ha la propria sede, a scelta di VENDITORE, in conformità alla valuta che VENDITORE indicherà nella relativa fattura di vendita.
- 5.3 Nel caso in cui CLIENTE sia in ritardo nell'esecuzione del pagamento, VENDITORE avrà diritto:
- a) al pagamento degli interessi legali di mora, in conformità alla legge applicabile;
- b) di sospendere le consegne ancora da eseguirsi, previa comunicazione scritta a CLIENTE, fino a quando gli importi dovuti e i relativi interessi di mora siano stati integralmente pagati.
- 5.4 Qualora tali importi e interessi risultino ancora non pagati una volta decorsi 30 (trenta) giorni dalla scadenza data di pagamento concordata, VENDITORE potrà altresì, a propria discrezione,

alternativamente o cumulativamente, e in aggiunta a qualsiasi altro diritto o rimedio allo stesso spettante in base alla legge o alle presenti CGV:

- a) esigere l'immediato pagamento di ogni debito residuo, anche se sia stato convenuto un pagamento a rate o un pagamento dilazionato e/o siano stati emessi e siano in scadenza cambiali tratte, pagherò cambiari, assegni o altri strumenti di pagamento;
  - b) risolvere il Contratto di Vendita in questione e trattenere definitivamente eventuali somme già ricevute in relazione a tale Contratto di Vendita e/o ad altri Contratti di Vendita, effettuando una compensazione fra il debito di CLIENTE e tutti i pagamenti ricevuti;
  - c) eseguire le future consegne dei Prodotti soltanto previo pagamento anticipato in relazione alle forniture ancora da eseguirsi;
  - d) revocare sconti e bonus che siano stati concordati fra le parti anche in relazione a Contratti di Vendita regolarmente eseguiti.
- 5.5 I diritti di cui ai precedenti paragrafi 5.3 e 5.4 potranno essere esercitati in qualsiasi momento da VENDITORE anche nel caso in cui:
- a) CLIENTE sia sottoposto a liquidazione, a procedure concorsuali, fallimentari, di ristrutturazione del debito o ad azioni esecutive; oppure
  - b) la compagnia assicurativa di VENDITORE rifiuti la copertura assicurativa di crediti di VENDITORE nei confronti di CLIENTE; oppure
  - c) CLIENTE versi in uno stato di difficoltà finanziaria - idoneo a determinare un pregiudizio al puntuale adempimento dei propri obblighi di pagamento - risultante, a titolo esemplificativo e non esaustivo, dalla levata di protesti, dalla diminuzione di garanzie concesse e/o dalla mancata prestazione di garanzie promesse, nonché dal verificarsi di qualsiasi insoluto, anche qualora tali circostanze si siano verificate nell'ambito dei rapporti tra CLIENTE ed altri suoi fornitori.
- 5.6 CLIENTE non potrà far valere eventuali inadempimenti di VENDITORE né potrà avviare alcuna azione legale nei confronti dello stesso fino a quando non abbia pagato integralmente a VENDITORE ogni importo allo stesso spettante ai sensi dei paragrafi 5.3 e 5.4.

## 6) Riserva di Proprietà

6.1 VENDITORE manterrà la proprietà dei Prodotti venduti fino al completo pagamento del loro prezzo da parte di CLIENTE.

Fermo restando quanto sopra, il rischio di perimento dei Prodotti sarà disciplinato dal termine di resa Incoterms® concordato tra le parti per la consegna dei Prodotti.

6.2 In caso di inadempimento o ritardo nell'adempimento dell'obbligo di pagare il prezzo dei Prodotti, fermo restando quanto previsto ai precedenti paragrafi 5.4, 5.5 e 5.6, VENDITORE avrà il diritto di accedere ai locali in cui si trovano i Prodotti, di rientrarne in possesso e di incamerare definitivamente, a titolo di penale, eventuali somme pagate da CLIENTE per i Prodotti in questione.

## 7) Garanzia

7.1 Fatto salvo quanto previsto ai precedenti paragrafi 2.1, 2.2, 2.4 e 3.6 in relazione alle modifiche ammesse ai Prodotti e alle tolleranze, VENDITORE garantisce a CLIENTE che i Prodotti saranno conformi al Contratto di Vendita, alla classificazione indicata nei manuali tecnici, cataloghi e/o listini prezzi di VENDITORE nonché privi di difetti di fabbricazione. La presente garanzia avrà la durata di 12 (dodici) mesi dalla data di ritiro dei Prodotti dallo stabilimento di VENDITORE, a prescindere dal termine di resa Incoterms® concordato.

7.2 Sono esclusi da qualsiasi garanzia:

- a) le alterazioni cromatiche e le differenze di tonalità dei Prodotti;
- b) i Prodotti classificati nel Contratto di Vendita come di qualità inferiore alla prima scelta ovvero come partite di Prodotti di fine serie venduta in blocco ovvero come partite speciali;
- c) i Prodotti non posati a regola d'arte e/o posati in modo difforme rispetto alle previsioni delle norme di settore applicabili;
- d) i Prodotti applicati su superfici e/o in ambienti diversi da quelli consigliati da VENDITORE;
- e) i Prodotti utilizzati in modo difforme rispetto alle istruzioni e/o indicazioni di VENDITORE incluse nei cataloghi e/o i listini di VENDITORE ovvero in altro modo comunicate a CLIENTE da VENDITORE ivi incluse le indicazioni di cui al precedente paragrafo 2.2;
- f) i Prodotti utilizzati in modo non conforme alla normale diligenza e/o alla tecnica richieste dalla natura dei Prodotti stessi;
- g) l'ingelività del Prodotto, a meno che tale caratteristica del Prodotto non sia stata dichiarata da VENDITORE nel manuale tecnico, in riferimento al Prodotto in questione;
- h) caratteristiche dei Prodotti come risultanti dalla classificazione del materiale ceramico (i) eseguita da parte di organismi di controllo e/o certificazione diversi da quelli di Paesi dell'Unione Europea e/o (ii) effettuata sulla base di criteri che non corrispondano a quelli utilizzati da VENDITORE.

7.3 Fermo quanto previsto al precedente paragrafo 4.4, CLIENTE sarà tenuto ad esaminare i Prodotti nel più breve tempo possibile e, a pena di decadenza dalla presente garanzia, a denunciare per iscritto a VENDITORE, a mezzo fax o email:

- a) difformità relative alla tipologia e/o alla quantità dei Prodotti ricevuti nonché altre difformità palesi dei Prodotti o loro difetti palesi: entro e non oltre 8 (otto) giorni dalla consegna dei Prodotti e, comunque, prima della posa in opera dei Prodotti;
- b) difformità occulte o difetti occulti dei Prodotti: entro e non oltre 8 (otto) giorni dalla scoperta e, comunque, entro il periodo di garanzia.

7.4 VENDITORE avrà il diritto di verificare i Prodotti, o alcuni campioni dei Prodotti, che CLIENTE ritenga essere difformi o difettosi, anche al fine di verificare il rispetto delle prescrizioni relative alla posa in opera degli stessi e/o all'applicazione e/o all'utilizzo dei Prodotti come rinvenibili dalle presenti CGV. A tale proposito, CLIENTE potrà restituire a VENDITORE i Prodotti dallo stesso ritenuti difformi o difettosi soltanto previa autorizzazione scritta di VENDITORE ed a condizione che CLIENTE si faccia integralmente carico delle spese e dei rischi di spedizione. L'autorizzazione al reso dei Prodotti o dei campioni asseritamente difformi o difettosi non costituirà in nessun caso riconoscimento delle difformità o dei difetti da parte di VENDITORE.

7.5 Nel caso in cui i Prodotti siano riconosciuti da VENDITORE come effettivamente difformi o difettosi, CLIENTE, a scelta di VENDITORE, avrà esclusivamente diritto:

- a) alla sostituzione gratuita dei Prodotti difformi o difettosi; oppure
- b) all'esenzione parziale o totale dal pagamento del loro prezzo, a seconda della gravità delle difformità o dei difetti.

7.6 Ai fini del paragrafo 7.5 lettera (a), i Prodotti che debbano essere consegnati in sostituzione di Prodotti difformi o difettosi saranno consegnati a CLIENTE in conformità alla regola Incoterms® 2010 ICC DDP - stabilimento di CLIENTE. I Prodotti che siano stati sostituiti dovranno essere, a scelta di VENDITORE, distrutti o smaltiti da CLIENTE, a spese di quest'ultimo, ovvero restituiti a VENDITORE, a spese di VENDITORE stesso. Per i Prodotti sostituiti che debbano essere distrutti o smaltiti da CLIENTE, CLIENTE si impegna ad inviare a VENDITORE la prova dell'avvenuta distruzione o smaltimento dei Prodotti, unitamente ai documenti giustificativi comprovanti il sostenimento dei costi di distruzione o smaltimento.

7.7 I diritti e rimedi descritti ai precedenti paragrafi 7.5 e 7.6 costituiscono i soli diritti e rimedi in garanzia concessi a CLIENTE. Nella massima misura consentita dalla legge, sono esclusi ulteriori responsabilità o obblighi di VENDITORE in relazione alla fornitura di Prodotti difformi o difettosi, ivi inclusi, a titolo esemplificativo e non esaustivo, responsabilità e obblighi per eventuali danni diretti, indiretti o consequenziali, perdite di profitto, ecc. a cui tale responsabilità si ricollega.

7.8 La presente garanzia sostituisce ed esclude ogni altra garanzia, espressa o implicita, prevista per legge o altrimenti.

## 8) Forza maggiore

8.1 VENDITORE non sarà in alcun modo responsabile per il mancato o ritardato adempimento di alcuna obbligazione relativa alla fornitura dei Prodotti qualora tale mancato o ritardato adempimento sia dovuto a eventi di forza maggiore come guerre, incendi, terremoti, inondazioni, tsunami, scioperi, difficoltà insorte con la forza lavoro, scarsità o difficoltà di approvvigionamento di materie prime, restrizioni all'uso di energia, sospensione o difficoltà nei trasporti, guasti agli impianti, atti della pubblica autorità o a qualsiasi altra azione o causa che non possa essere ragionevolmente prevista o alla quale VENDITORE non possa ragionevolmente porre rimedio tramite l'ordinaria diligenza.

8.2 In tali eventualità, il termine per l'esecuzione della fornitura verrà esteso per tutto il periodo di durata dell'evento di forza maggiore, fermo restando che, qualora tale evento dovesse impedire l'esecuzione della fornitura per oltre 6 (sei) mesi, CLIENTE avrà il diritto di risolvere il relativo contratto di vendita, mediante invio di lettera raccomandata con ricevuta di ritorno o corriere a VENDITORE, senza alcuna responsabilità o conseguenza per VENDITORE.

## 9) Invalidità di singole clausole contrattuali

L'invalidità di una disposizione delle presenti CGV non comprometterà la validità delle residue disposizioni che rimarranno pienamente valide e efficaci.

## 10) Riservatezza

10.1 CLIENTE si impegna a: (i) trattare come riservati tutte le informazioni/dati/disegni/know-how/documentazione trasmessigli da VENDITORE ovvero di cui sia venuto a conoscenza nell'esecuzione dei singoli Contratti di Vendita, indipendentemente dal fatto che tali informazioni siano o meno contrassegnate o identificate come riservate o confidenziali ("Informazioni Riservate"); (ii) non divulgare e non comunicare a terzi, né in tutto né in parte, le Informazioni Riservate senza il preventivo consenso scritto di VENDITORE; (iii) limitare l'utilizzo di tali Informazioni Riservate ed il relativo accesso per scopi relativi all'esecuzione dei singoli Contratti di Vendita; (iv) adottare tutte le misure necessarie al fine di assicurare che i propri dipendenti e i propri collaboratori evitino di divulgare a terzi le Informazioni Riservate o le utilizzino in modo improprio. Le Informazioni Riservate non potranno essere riprodotte senza previo consenso scritto di VENDITORE, e tutte le copie delle stesse saranno immediatamente restituite dietro richiesta di VENDITORE.

10.2 Le previsioni di cui sopra non si applicano alle informazioni che: (i) sono pubbliche o divengono pubbliche non per divulgazione da parte del CLIENTE, dei suoi dipendenti o collaboratori, o (ii) erano in possesso del CLIENTE prima che le ricevesse da VENDITORE o (iii) sono state divulgate da fonti che non sono sottoposte alle restrizioni cui è sottoposto CLIENTE relativamente al loro utilizzo, o (iv) possono essere divulgate a terzi in base ad un'autorizzazione scritta di VENDITORE.

## 11) Legge applicabile - Risoluzione delle controversie

11.1 Le presenti CGV e tutti i Contratti di Vendita che le parti stipuleranno in base alle presenti CGV saranno regolati dalla Convenzione di Vienna del 1980 sulla vendita internazionale di merci e, nelle materie non coperte da tale Convenzione, dalla legge italiana.

11.2 Qualsiasi controversia relativa alle presenti CGV e/o ai Contratti di Vendita che interverranno sulla base delle stesse sarà decisa in conformità alle seguenti previsioni:

- a) qualora CLIENTE abbia la sua sede legale nell'Unione Europea, in Svizzera, in Norvegia o in Islanda, la controversia sarà assoggettata in via esclusiva alla giurisdizione italiana e, in relazione ad essa, sarà esclusivamente competente il Tribunale di Modena (Italia);
- b) in tutti gli altri casi, la controversia sarà decisa in via esclusiva e definitiva mediante arbitrato, celebrato da un arbitro unico, in conformità al Regolamento di Procedura della Camera Arbitrale di Milano.

L'arbitrato avrà sede, e il lodo arbitrale verrà pronunciato, nella città di Milano (Italia). La lingua dell'arbitrato sarà la lingua inglese.

11.3 È tuttavia concesso, unicamente a favore di VENDITORE, il diritto incondizionato di agire, in qualità di attore, sotto la giurisdizione di CLIENTE innanzi al tribunale competente.

## 12) Lingua delle CGV

12.1 Il testo delle presenti CGV è redatto sia in lingua italiana che in lingua inglese.

In caso di discrepanza, il testo in lingua italiana prevarrà sul testo in lingua inglese.

**Le presenti condizioni generali di vendita sono pubblicate e scaricabili sul sito internet [www.panariagroup.it](http://www.panariagroup.it)**

## GENERAL TERMS AND CONDITIONS OF SALE

### 1) Scope Of Application

- 1.1 These General Terms and Conditions of Sale ("General Conditions") shall apply to any and all supply of ceramic tiles or other ceramic products ("Products") that will be executed to any client ("CLIENT") from any company or division of the Group Panariagroup Industrie Ceramiche S.p.A. ("SELLER"), even if these General Conditions are not expressly referred to, mentioned or expressly accepted by the CLIENT from time to time.
- 1.2 No provisions deviating from these General Conditions shall be binding on SELLER unless (i) included in the "Sale Contract", as defined under paragraph 3.2 below, (ii) included in documents following the Sale Contract and the content of the same has been accepted in writing by SELLER. In any case, even if deviating provisions are agreed upon, these General Conditions shall apply for the parts not expressly disregarded.
- 1.3 In no case shall any general conditions of contract of CLIENT be binding on SELLER, even if mentioned or included in orders or in any other documents transmitted by CLIENT to SELLER. No conduct of SELLER shall be interpreted or used in order to express tacit acceptance of SELLER to the general conditions of contract of CLIENT.
- 1.4 In no case SELLER shall be bound by acts and/or conducts of its agents, being the latter in lack of any power to bind SELLER.
- 1.5 In case CLIENT is a consumer, the provisions of these General Conditions shall not prejudice the rights of CLIENT provided for by the law applicable to sales executed toward consumers.

### 2) Products – Modifications

- 2.1 Any representation and/or image relating to the Products included in websites, brochures, catalogues, price lists or other similar documents of SELLER is approximate and purely illustrative. As a consequence, such representations and/or images do not represent the final aesthetic result of the Products. Technical and physical characteristics of the Products as well as qualities of the same are described in the technical manuals of SELLER only. Any other document including technical and physical characteristics and qualities of the Products are purely indicative and shall not bind SELLER.
- 2.2 SELLER declares that the Products are compliant with the applicable Italian and European industry standards. Any Products shall be used and applied in accordance with the instructions of use of SELLER included in catalogues and/or technical manuals of SELLER with reference to the Products in question or with the instructions in other way communicated and/or made available by SELLER to CLIENT and, in any case, in accordance with the diligence required by the nature of the Products. Failing to do so, CLIENT will result in the lapse of the warranty and in the unenforceability of the warranty rights under article 7 below or of any other legal or agreed warranty.
- 2.3 It is the responsibility of CLIENT, before executing of the Sale Contract, to make sure that the Products are suitable for their specific purpose and/or intended use and, in addition, that they also comply with the laws and regulations applicable in the place where CLIENT will import, distribute, sell or use them in any way.
- 2.4 SELLER may make any changes to the Products which, without altering their essential features, it deems necessary or convenient, even after execution of the Sale Contract. In case SELLER executes substantial modification to Products (e.g. modifications that will alter: the way of installation, characteristic of interchangeability of the Products, etc.) which are the object of an executed Sale Contract (as defined in paragraph 3.2 below), SELLER shall communicate in writing such modification to CLIENT.
- 2.5 CLIENT shall inform the purchasers of the Products and third parties of the characteristics of the Products and of the instructions of use and of application of the same in accordance with the indication provided by SELLER. Without prejudice to the above, CLIENT shall be the sole responsible and liable for the declarations it will make toward third parties with reference to the Products, their characteristics and their use or application and shall indemnify and hold SELLER harmless and from any damage possibly suffered by SELLER with reference to or in connection to such declarations of CLIENT, in case they result false, incomplete or inaccurate.

### 3) Quotations – Execution of Sale Contract – Tolerances

- 3.1 Written or verbal quotations issued by SELLER are not to be taken as valid contractual proposals.
- 3.2 The sale contract ("Sale Contract") is executed as follows:
- a) an offer is sent by SELLER to CLIENT and CLIENT then sends its written acceptance of such offer to SELLER, without any modification to the offer itself; or
  - b) a purchase order is sent by CLIENT and SELLER then sends its written acceptance of such order to CLIENT.
- 3.3 For the purposes of paragraph 3.2 letter a) above, the following facts or actions shall constitute the written acceptance of an offer of SELLER by CLIENT:
- a) the receipt by SELLER of a letter of credit sent by CLIENT;
  - b) the receipt by SELLER of all or part of the relevant purchase price;
  - c) the receipt by SELLER of a purchase order of CLIENT. Should this be the case, any order of CLIENT that differs from the provisions of the offer of SELLER shall be binding on SELLER only if and to the extent that SELLER had expressly accepted it in writing.
- 3.4 In addition, for the purposes of paragraph 3.2 letter b) above, in case the acceptance of SELLER includes terms and condition different from those of the order of CLIENT, the Sale Contract shall be deemed to be concluded at the conditions included in the acceptance of SELLER, unless CLIENT notifies SELLER, in writing, not to accept the terms and conditions of the acceptance of SELLER within 1 (one) working day from the receipt of such acceptance.
- 3.5 All supplies of Products will only include what is expressly indicated in Sale Contract.
- 3.6 CLIENT recognizes to SELLER quantity and quality tolerances as resulting from the Sale Contract or from the usage and practices of the sector of the Products.

### 4) Packing – Delivery term – Delivery time

- 4.1 The Products will be packaged and readied to ship in compliance with the standard protection methods generally adopted by SELLER for the Products in question, in consideration of the agreed mode of transport. CLIENT shall expressly request to SELLER any special packaging or supplementary protection it deems necessary, and in such event CLIENT will bear all related costs thereof.
- 4.2 Unless otherwise provided for in the Sale Contract, the Products shall be delivered to CLIENT in accordance with the Incoterms® ICC rule, latest version, Ex-Works (EXW) – premises of SELLER indicated in the Sale Contract. CLIENT authorizes SELLER to undersign, in the name and on behalf of CLIENT, any and all transport documents which shall be signed at the time of collection of the Products at the premises of SELLER, such as the CMR. In the event that the ICC Incoterms® rule agreed between the parties provides that CLIENT shall take care of the transportation of the Products outside the territory of Italy:
- a) in case of an Intra-EU supply, within 45 (forty-five) days from the receipt of the Products at its premises, CLIENT shall send SELLER an original or a copy of the international transportation document CMR or of another transportation document, undersigned at destination by CLIENT or, in the absence of the international transportation document CMR, a declaration of receipt of the Products issued on the basis of the form as Annex -1- available for download at [www.panariagroup.it](http://www.panariagroup.it);
  - b) in case of an Extra-EU supply, CLIENT shall:
    - i) submit the custom export declaration (SAD-EX + EAD) and execute the validation of the MRN (Movement Reference Number) at the customs of the UE territory of exit of the Products, within 90 (ninety) days from the date of delivery of the same in Italy;
    - ii) send SELLER, within 90 (ninety) days from the date of delivery, documents proving the exportation of the Products (custom export declaration SAD-EX + EAD + certification of exit);
    - iii) notify SELLER, in writing, as soon as such submission is accomplished and provide SELLER with any other document proving the execution of such formalities as well as the exit of the Products from the UE Territory.
- In case CLIENT is in breach of its obligations under this paragraph 4.2, SELLER shall be entitled to immediately charge CLIENT the amount of the Value Added Tax applicable to the supply and connected to the lack of proof of the transportation of the Products in a another Member State of the EU or to the lack of execution of custom clearance formalities. In any case, CLIENT shall indemnify and hold SELLER harmless with reference to any payment due to tax offices for fines, interests or on any other basis, in connection with the supply and with the lack of the proof of the transportation of the Products in a another Member State of the EU or with the lack of execution of custom clearance formalities.
- In this respect, SELLER shall be entitled to: (i) offset any amount due by CLIENT on the basis of this paragraph 4.2 against any amount due, for whatever reason, from SELLER to CLIENT; or (ii) definitively withhold any amount received in regard to Sale Contracts, offsetting the CLIENT's debt under this paragraph 4.2 against any and all sums already paid by CLIENT.
- 4.3 SELLER shall deliver the Products within the delivery date provided for in the Sale Contract, in a single delivery or in partial deliveries. The delivery date shall always be considered neither of the essence nor peremptory. Except in case of wilful wrongdoing or gross negligence, SELLER will not reimburse possible damages, either direct or indirect, suffered by CLIENT as a result of delay in the delivery of the Products.
- In no case of delay in the delivery of the Products shall CLIENT be entitled to terminate the Sale Contract.
- 4.4 Upon receipt of the Products, CLIENT must report possible damages occurred to the packaging and/or shortages or anomalies of the Products occurred during the transport, by notifying details of such events on the transportation document, and must also:
- a) have such notification countersigned by the carrier; and
  - b) immediately inform SELLER thereof, in writing, and send SELLER a copy of the countersigned document by and no later than 8 (eight) day(s) from the date of receipt of the Products.
- Should this not be the case, SELLER shall not be responsible for possible damages losses or theft of the Products occurred during the transport, even if transport risks were, in whole or in part, upon SELLER.

### 5) Prices – Payment – Late Payment

- 5.1 The Products shall be supplied at the prices agreed between the parties in the Sale Contract or, should no prices be mentioned in the Sale Contract, at the prices resulting from the price list of SELLER in force when the Sale Contract has been executed. Unless otherwise stated in writing, the prices of the Products included in SELLER's price lists, quotations and/or offers are in Euro, net of VAT and for delivery according to the Incoterms® ICC rule, latest version, Ex-Works (EXW) - premises of SELLER indicated in the Sale Contract. Therefore, should a different Incoterms® rule be agreed upon between the parties for the delivery of the Products, the invoiced amount shall be modified accordingly, including in the sale invoice transportation expenses and any other costs connected with the Incoterms® rule agreed between for delivery.
- 5.2 CLIENT shall pay for the Products in accordance with the payments methods and terms provided for in the Sale Contract or otherwise agreed upon in writing between the parties. No payment shall be considered as being made by CLIENT until the relative amount has been credited to the bank account of SELLER. Payment shall be executed by CLIENT in Euro or in the currency of the place where CLIENT has its registered office, at SELLER's discretion, in accordance with the currency indicated by SELLER in the related sale invoice.
- 5.3 If CLIENT is delinquent in its payment obligation, SELLER may:
- a) obtain payment of late payment interest in accordance with the applicable law; and
  - b) withhold ongoing and future deliveries, upon written notice to CLIENT, until all delinquent amounts and late payment interest are fully paid.
- 5.4 If delinquent amounts and late payment interest remain unpaid 30 (thirty) days after the agreed deadline for payment, then SELLER may also, at its option, alternatively or cumulatively, and in addition to any other right or remedy available at law or pursuant to these General Conditions:

- a) request accelerated payment of any and all remaining payments and declare due the total outstanding balance, even if payment by instalment or deferred payment has been agreed upon and/or bills of exchange, promissory notes, cheques or other payment documents have been issued and are falling due;
- b) terminate the Sale Contract in question and definitively withhold any amount received in regard to such Sale Contract or to other Sale Contracts, offsetting the CLIENT's outstanding debt against any and all sums already paid by CLIENT;
- c) carry out future deliveries of Products on a pre-payment basis only, also with reference to supplies still to be executed;
- d) cancel discounts and bonuses that may have been agreed between the parties also with reference to Sale Contracts already regularly executed.

5.5 SELLER shall be entitled to exercise the rights mentioned in paragraphs 5.3 and 5.4 above also in case:

- a) CLIENT is undergoing winding-up, bankruptcy, debt restructuring or enforcement proceedings;
- b) the insurance company of SELLER refuses insurance coverage for SELLER's credits toward CLIENT;
- c) CLIENT is undergoing financial difficulties able to hinder the regular execution of its payment obligations resulting from, by way of example only, missed payment of bills of exchange, promissory notes, cheques or other payment documents, reduction of granted guarantees and/or missed granting of promised guarantees, as well as from any amount resulting unpaid, even though such circumstances have occurred with other suppliers of CLIENT.

5.6 CLIENT cannot claim any breach of contract by SELLER, nor can CLIENT start any lawsuit or action against SELLER, until any amount resulting due to SELLER under paragraphs 5.3 and 5.4 above has been paid in full by CLIENT.

#### 6) Retention of Title

6.1 SELLER will maintain exclusive ownership over the Products sold until their price has been entirely paid by CLIENT.

Without prejudice to the above the risks of loss of the Products shall be regulated by the Incoterms® rule agreed between the parties for the delivery of the Products.

6.2 In case of non-fulfilment or late fulfilment of the obligation to pay the price of the Products, without prejudice to the rights under paragraphs 5.4, 5.5 and 5.6, SELLER shall be entitled to enter the premises where the Products are held, re-possess the Products and withhold, as liquidated damages, any amount already paid by CLIENT with reference to such Products.

#### 7) Warranty

7.1 Without prejudice to the provisions of paragraphs 2.1, 2.2, 2.4 and 3.6 with reference to the modifications to the Products and tolerances, SELLER warrants that the Products will conform to the Sale Contract, to the classification indicated in the technical manuals, catalogues and/or price lists of SELLER and that they will be free from manufacturing defects.

The warranty period is 12 (twelve) months from the date of collection of the Products from the premises of SELLER, regardless of the agreed Incoterms® rule for delivery.

7.2 The following are expressly excluded from warranty:

- a) chromatic alterations and tone differences of the Products;
- b) the Products identified in the Sale Contract as Products of quality lower than first-quality Products or as close-out sale Products or as special batches;
- c) the Products applied and/or set up not in compliance with the industry standards applicable to the same;
- d) the Products used or applied on surfaces and/or in spaces or environments different from those indicated by SELLER;
- e) the Products used not in compliance with the instructions and/or indications provided by SELLER included in the catalogues and price lists of SELLER or in other way communicated to CLIENT by SELLER, included the instructions under paragraph 2.2;
- f) the Products used not in compliance to the standard diligence and/or to the technics required by the nature of the Products;
- g) frost resistance of the Products, unless such characteristic of the Products has been declared by SELLER in the technical manual of the Products;
- h) characteristics of the Products as resulting from the classification of the pottery (i) executed by control and/or certification authorities other than authorities of the European Union Member States, and/or (ii) executed on the basis of criteria other than those used by SELLER.

7.3 Without prejudice to the provisions of paragraph 4.4 above, CLIENT shall inspect the Products as soon as possible and shall notify SELLER in writing of possible non-conformities or defects, by fax or email, within and no later than the following terms; failing to do so will result in the lapse of the warranty and the unenforceability of the warranty rights:

- a) differences in type or quantity with respect to type or quantity agreed as well as other patent non-conformities or defects of the Products: 8 (eight) days from the delivery of the Products at the premises of CLIENT and, in any case, before application of the Products;
- b) hidden non-conformities or defects of the Products: 8 (eight) days from the discovery of the same and, for avoidance of doubt, within the warranty period.

7.4 SELLER will have the right to examine the Products, or samples of the Products, which CLIENT claims to be non-conforming or defective, in order to verify the instructions relating to the set up and/or application of the Products and/or the use of the Products in accordance with the provisions of these General Conditions. In this respect, CLIENT shall be entitled to return to SELLER the Products that CLIENT considers to be non-conforming or defective only upon SELLER's written authorization and only on the condition that CLIENT bears all costs and risks for the shipment of the Products. The authorization to return the Products or samples of the purportedly non-conforming or defective Products shall never be interpreted as an acknowledgment of the claimed non-conformities or defects on the part of SELLER.

7.5 In case the Products are ascertained by SELLER as actually non-conforming or defective, CLIENT will be entitled only to obtain, at the SELLER's option:

- a) replacement of the non-conforming or defective Products; or
- b) partial or full exemption from payment of their price, depending on the seriousness of the non-conformities or of the defects.

7.6 For the purpose of paragraph 7.5 letter (a), the Products to be delivered in replacement of non-conforming or defective Products shall be delivered to CLIENT in accordance with the Incoterms® 2010 ICC rule DDP - premises of CLIENT. The Products that have been replaced shall be, at SELLER's discretion, destroyed or disposed of by CLIENT, at its own costs, or returned to SELLER, at costs of SELLER. In case the Products are to be destroyed or disposed of by CLIENT, CLIENT undertakes to send to SELLER the proof of destruction or of disposal of the Products, along with the documents proving the costs borne by CLIENT for the destruction or the disposal of the same.

7.7 The rights and remedies described in paragraphs 7.5 and 7.6 above are the sole warranty rights and remedies granted to CLIENT. To the maximum extent permitted by the applicable law, any other liability and obligation of SELLER, which may in any way arise from or in relation to the supply of non-conforming or defective Products - including, but not limited to, compensation for direct or indirect or consequential damages, loss of profits, etc. connected to such liability - is expressly excluded.

7.8 The present warranty is in substitution for, and excludes, any other warranty, express or implied, set forth by the law or otherwise.

#### 8) Force Majeure

8.1 SELLER shall not be liable or responsible for failure or delay in performing or fulfilling any obligations undertaken in reference to the supply of Products when such failure or delay is due to the occurrence of an event of force majeure such as wars, fires, earthquakes, floods, tsunamis, strikes, labor or employment difficulties, shortage or procurement difficulties of raw materials, restriction on the use of power, suspension or difficulties in the transports, breakdown of the plants, acts of public authorities or any other event or cause whatsoever, similar or dissimilar, which cannot reasonably be forecast or provided against and which cannot be overcome by SELLER with reasonable diligence.

8.2 In such event, the time for fulfilment of the obligation shall be extended for the period of continuance of such force majeure event.

In the event any of such force majeure event continue for a period longer than 6 (six) months, CLIENT shall have the right to terminate the underlying Sale Contract, by giving written notice to SELLER by registered letter with return receipt or courier, and SELLER shall not incur any responsibility or liability whatsoever.

#### 9) Severability

The invalidity or unenforceability of any provision, or portion thereof, of this General Conditions shall not affect the validity or enforceability of any other provision.

#### 10) Confidentiality

10.1 CLIENT undertakes: (i) to treat with the utmost confidentiality all the information/data/designs/know-how/documentation transmitted by SELLER or that it may come to know in connection with the execution of any Sale Contract, even if they are not marked or identified as secret or confidential ("Confidential Information"); (ii) not to, wholly or partially, disclose to or inform third parties of the Confidential Information, without the SELLER's prior written consent; (iii) to limit the use of the Confidential Information and the access to the same for purposes relating to the execution of the sale Contracts; (iv) to adopt any and all measures required in order for its employees and collaborators do not disclose the Confidential Information to third parties or use it in an inappropriate way.

The Confidential Information shall not be copied or reproduced in any way, unless with the prior written consent of SELLER, and all the copies of the Confidential Information shall be immediately returned to SELLER upon simple written request of the same.

10.2 The provisions above shall not apply to information which (i) are public or publicly available not due to a disclosure of CLIENT or of CLIENT's employees or collaborators; or (ii) were already available to CLIENT before it had received them by SELLER; or (iii) are disclosed from third parties that have no obligation of confidentiality or restrictions of use on the same; (iv) can be disclosed according to a written authorization of SELLER.

#### 11) Applicable Law – Dispute Resolution

11.1 These General Conditions and all the Sale Contracts that will occur on the basis on the same will be governed by the United Nations Convention on Contracts for the International Sale of Goods (Vienna Convention of 1980) and, with respect to matters not covered by such Convention, by Italian laws.

11.2 Any dispute arising out of or in connection with these General Conditions or in connection with a Sale Contract occurred on the basis on the same shall be settled in accordance with the following provisions:

- a) In case CLIENT has its registered office within the European Union, in Switzerland, in Norway or in Iceland, the dispute shall be subjected to the jurisdiction of the Italian courts and shall be exclusively referred for its resolution to the Court of Modena (Italy).
- b) In any other case, the dispute shall be exclusively referred to and finally resolved by arbitration, by a sole arbitrator, in accordance with the Rules of the Milan Chamber of Arbitration (the Rules).

The seat of arbitration shall be, and the award shall be delivered in, Milan (Italy).

The language to be used in the arbitral proceedings shall be English.

11.3 Irrespective of the provisions above, it is hereby granted exclusively to SELLER the right to initiate legal proceedings under the jurisdiction of CLIENT before the competent court.

#### 12) Language of these General Conditions

12.1 The text of these General Conditions is executed in both in Italian and in English language. In case of any discrepancy, the text in Italian shall prevail over the text in English language.

**These general terms and conditions of sale are published and downloadable on the website [www.panariagroup.it](http://www.panariagroup.it)**



Le rappresentazioni fotografiche e descrittive dei prodotti di Lea Ceramiche riportate sui depliant, sui cataloghi e sugli altri materiali pubblicitari dell'azienda, sono puramente illustrative dello specifico prodotto rappresentato.

Si precisa infatti che, successivamente alla pubblicazione dei materiali pubblicitari dell'azienda, il prodotto potrebbe subire leggere modifiche nel relativo processo produttivo, al fine di renderlo tecnologicamente migliore. Tali aggiustamenti tecnologici potrebbero determinare lievi differenze, anche estetiche e/o cromatiche, nel prodotto medesimo, con la conseguenza che lo stesso potrebbe risultare diverso da come rappresentato e/o illustrato e/o descritto nel materiale pubblicitario di Lea Ceramiche. Tali differenze non potranno essere in alcun modo considerate dall'acquirente un vizio e/o difetto del materiale ceramico stesso, bensì una caratteristica dello specifico prodotto. Tutti i materiali ceramici che imitano pietre naturali presentano differenze di colore e sfumature che non potranno in nessun modo essere considerate quale difetto del prodotto, ma bensì una qualità caratteristica di tali tipi di produzione.

The photographs and descriptions of Lea Ceramiche products given in the brochures, catalogues and other corporate advertising materials aim merely to represent the specific products.

After the publication of the corporate advertising materials, the products may be slightly modified as a result of technological improvements. Such technological modifications may lead to slight differences in appearance and/or colour of the products, which may therefore differ from the representations, illustrations or descriptions given in the Lea Ceramiche advertising materials. Such differences shall in no way be deemed to be faults and/or defects in the ceramic materials, but rather intrinsic features of the specific products.

All ceramic materials that imitate natural stone differ in color and nuances, and this cannot in any way be considered as a product defect, but rather a characteristic of these types of products.

Les représentations photographiques et descriptives des produits de Lea Ceramiche reportées au sein des dépliant, des catalogues et des autres matériels publicitaires de l'entreprise visent simplement à illustrer le produit spécifique représenté.

En effet, nous précisons que suite à la publication des matériels publicitaires de l'entreprise, le produit pourrait subir de légères modifications lors du processus de production afin de le rendre meilleur du point de vue technologique. Ces ajustements technologiques pourraient engendrer de légères différences, même esthétiques et/ou chromatiques, au niveau du produit même, impliquant que celui-ci pourrait diverger des représentations et/ou des illustrations et/ou des descriptions contenues dans le matériel publicitaire de Lea Ceramiche. Ces différences ne pourront en aucun cas être considérées par l'acquéreur comme une imperfection et/ou un défaut du matériau céramique, mais plutôt comme une caractéristique du produit spécifique.

Tous les matériaux céramiques imitant les pierres naturelles présentent des différences de couleur et des nuances qui ne pourront en aucun cas être considérés comme un défaut du produit, mais, en revanche, comme une caractéristique typique de ces productions.

Die in den Prospekten, Katalogen und sonstigen Werbematerialien der Firma enthaltenen fotografischen Darstellungen und Beschreibungen der Produkte von Lea Ceramiche dienen nur zur Veranschaulichung des jeweils dargestellten Produkts.

Wir weisen darauf hin, dass nach der Veröffentlichung der Werbematerialien der Firma leichte Änderungen bezüglich des Produktionsprozesses am Produkt vorgenommen werden könnten, um es in technologischer Hinsicht zu verbessern. Diese technischen Abänderungen könnten zu leichten z.B. ästhetischen und/oder farblichen Unterschieden am Produkt führen, das folglich von dem im Werbematerial von Lea Ceramiche dargestellten und/oder veranschaulichten und/oder beschriebenen Produkt abweichen könnte. Diese Unterschiede dürfen vom Käufer in keiner Weise als Mangel und/oder Defekt des Keramikmaterials angesehen werden, sondern sind ein Merkmal des spezifischen Produkts. Die keramischen Materialien die Natursteine nachbilden (imitieren), die Farbunterschieden haben, sind nicht als Fehler des Materials zu bezeichnen, sondern als typische Merkmale.





# LEA

CERAMICHE

LEA CERAMICHE  
Via Cameazzo, 21  
41042 Fiorano Modenese  
Modena Italy

Tel +39 0536 837811  
info@ceramichelea.it  
www.ceramichelea.com

MILANO  
Showroom Lea Ceramiche  
Via Durini, 3  
20122 Milano

Tel +39 02 76011406  
showroom\_milano@ceramichelea.it

PARIGI  
Temporary Lab  
Rue Therese, 20 - Rue des Moulins, 1  
1.ere Arrondissement  
Métro Pyramides  
75001 Paris

Tel +33 648116844

USA  
Lea North America, LLC  
800 Clanton Road, Suite N  
Charlotte, NC 28217

Tel +1 704 522 6300  
info@leausa.us  
www.leausa.us

Panariagroup Industrie Ceramiche S.p.A.  
www.panariagroup.it